

# CARTEK<sup>®</sup>

## AUTOPARTES

### CATÁLOGO DE EMBRAGUES

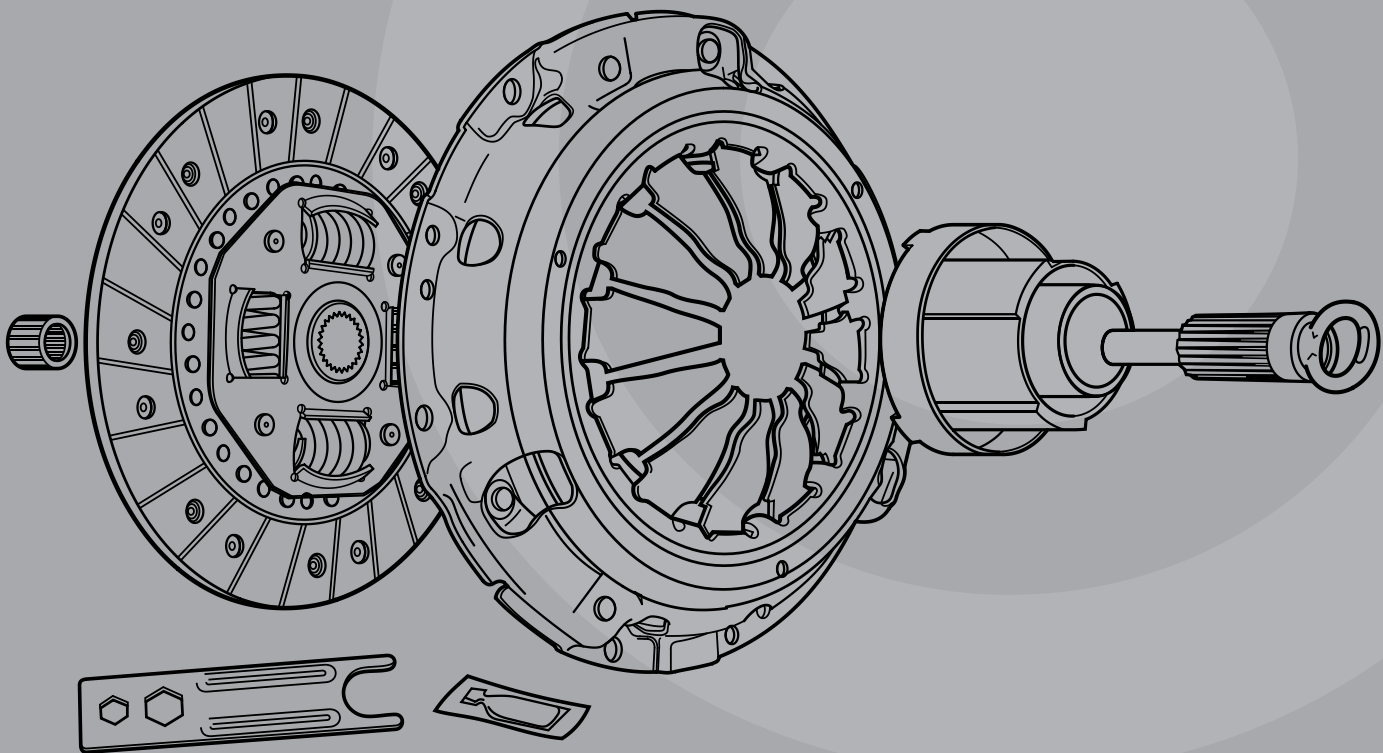

CATÁLOGO DE EMBRAGUES



**PROFESSIONAL**  
DRIVER'S CHOICE

[www.cartek.com.mx](http://www.cartek.com.mx)





## Diseñado para instalarse más fácil y rápido, utilizando las tuberías existentes y sin requerir herramientas especiales

El conector TECH-link™ del cual la Patente esta pendiente trabaja con la tuberías hidráulicas existentes, se conecta en segundos y no requiere de herramientas especiales. ¡No más daños a las tuberías!

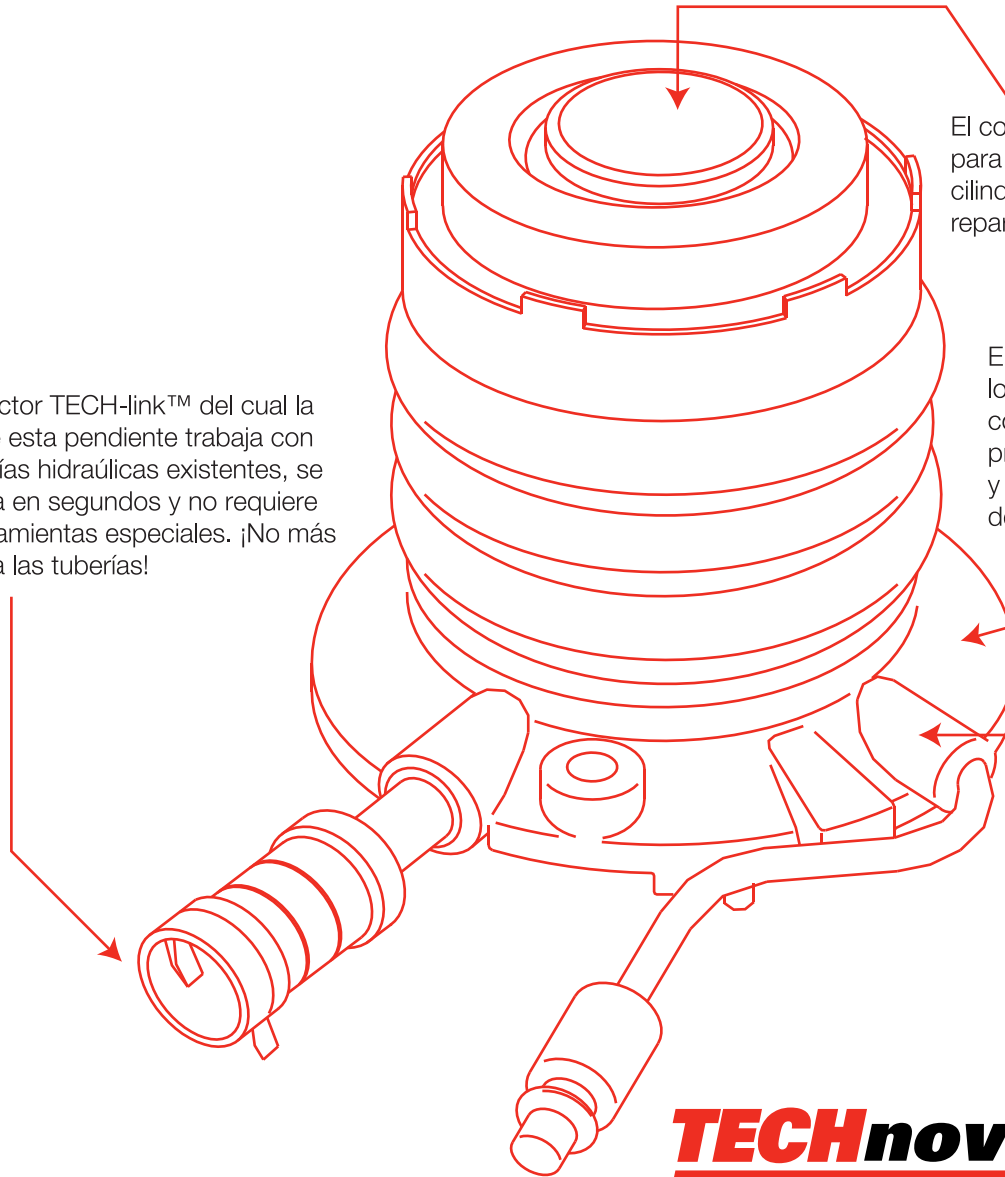

El collarín está diseñado para que exceda la vida del cilindro esclavo, y así eliminar reparaciones innecesarias.

El cubrepolvo de todos los cilindros esclavos concéntricos (CSC) los protege de la contaminación y extiende enormemente su desempeño.

El cuerpo de los cilindros de aluminio anodizado es más fuerte y durable que el original de poliamida.

### **TECH**novation™

Clutch Hydraulics

Los diseñadores de equipo original piensan en la instalación del clutch en la línea de ensamble, no piensan en Usted. Nosotros si lo hacemos. Ustedes son en quien pensamos. Es por ello que los Ingenieros que trabajan en el departamento de desarrollo de nuevos productos diseñaron TECHnovation™ Sistema Hidráulico de Clutch.

Los productos TECHnovation™ se instalan más fácil y rápido que los de equipo original y estan respaldados por el mejor equipo de asistencia técnica del mercado. Usted podrá contar con la asistencia técnica de un especialista de clutch. Hoy más que nunca es fácil dar "Servicio al Sistema Completo de Clutch Hidráulico con productos TECHnovation™.

Venta directa en México contactar:  
01 800 627.2044 Guadalajara, Jal.  
01 800 711.6368 Morelia, Mich.  
01 800 633.5455 Culiacán, Sin.

Distribuciones en Latinoamerica de productos  
CARTEK contactar: (+52) 33 3837.5610



[www.cartek.com.mx](http://www.cartek.com.mx)



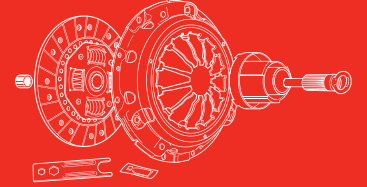

## ÍNDICE:

Acura -Automóvil.....	2
Audi - Automóvil.....	2
Buick - Automóvil.....	2
Cadillac - Automóvil.....	2
Chevrolet - Automóvil.....	2
Chevrolet / GMC - Pick-Up / Camioneta.....	5
Chevrolet / GMC - Microbús.....	14
Chevrolet / GMC - Camión.....	14
Chrysler / Dodge - Automóvil.....	15
Chrysler / Dodge - Pick-Up / Camioneta.....	17
Chrysler / Dodge - Microbús.....	21
Fiat - Automóvil.....	21
Ford - Automóvil.....	21
Ford - Pick-Up / Camioneta.....	23
Ford - Microbús.....	30
Geo.....	30
Honda - Automóvil.....	31
Honda - Camioneta.....	31
Isuzu - Pick-Up / Camioneta.....	31
Isuzu - Camiones.....	32
Jeep.....	32
Mazda - Automóvil.....	33
Mazda - Pick-Up / Camioneta.....	34
Mercury - Automóvil.....	35
Mitsubishi - Automóvil.....	35
Mitsubishi - Pick-Up / Camioneta.....	35
Mini Cooper.....	36
Nissan - Automóvil.....	36
Nissan - Pick-Up / Camioneta.....	38
Peugeot - Automóvil.....	39
Peugeot - Furgoneta.....	39
Pontiac - Automóvil.....	39
Renault - Automóvil.....	41
Renault - Furgoneta.....	41
Seat - Automóvil.....	41
Suzuki.....	42
Toyota - Automóvil.....	42
Toyota - Pick-Up / Suv / Camioneta.....	43
Vam.....	43
Volkswagen - Automóvil.....	43
Volkswagen - Pick-Up / Camioneta.....	46
Catálogo de Cilindro esclavo concéntrico.....	47
Lista de equivalencia de número de parte.....	51
Boletines.....	54
Notas.....	56



> PISTONES PARA CALIPER  
 > KITS DE CALIPER  
 > KITS PARA RUEDA  
 > KITS DE TAMBOR

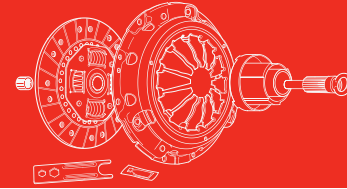

APLICACIÓN	01	NÚMERO DE PARTE	MODULAR	AUTO-AJUSTABLE	VOLANTE BILMASA	COLL. HID. INCLUIDO	NÚMERO DE IMAGEN COLL. HID.	PÁGINA DE IMAGEN COLL. HID.	DIÁMETRO	ESTRIADO
<b>ACURA - AUTOMÓVIL</b>										
<b>CL</b>										
L4 2.2L (145HP) 5 Vel.	97	EJ-H23A							8 7/8" - 225mm	24D - 23.0 x 26.6
L4 2.3L (150HP) 5 Vel.	98-99	EJ-H23A							8 7/8" - 225mm	24D - 23.0 x 26.6
<b>AUDI - AUTOMÓVIL</b>										
<b>A3</b>										
L4 1.8L Turbo 150/180HP, 5/6 Vel.	98-04	EJ-VW22E	X		X				8 11/16" - 220mm	28D
L4 1.8L Turbo 150/180HP, 5/6 Vel. Versión Volante Sólido (Incluye Volante Sólido)	98-04	EJ-VW22ES							8 11/16" - 220mm	28D - 19.75x22
L4 2.0L 150HP, FSI	04-07	EJ-VW23G	X	X	X				9" - 228mm	28D
<b>TT</b>										
L4 1.8L Turbo 180HP, 5 Vel.	98-05	EJ-VW22E	X		X				8 11/16" - 220mm	28D
L4 1.8L Turbo 180HP, 5Vel Versión Volante Sólido (Incluye Volante Sólido)	98-05	EJ-VW22ES							8 11/16" - 220mm	28D - 19.75x22
<b>BUICK - AUTOMÓVIL</b>										
<b>Skyhawk</b>										
L4 2.0L 5 Vel.	83-86	EJ-GM22E							8 1/2" - 216mm	14D - 21.5 x 25.1
L4 2.0L 4 Vel.	87	EJ-GM23C							9 3/16" - 233mm	14D - 21.5 x 25.1
<b>Skylark</b>										
L4 2.5L	80-85	EJ-GM23C							9 3/16" - 233mm	14D - 21.5 x 25.1
L4 2.5L	85-89	EJ-GM22E							8 1/2" - 216mm	14D - 21.5 x 25.1
V6 2.8L	80-85	EJ-GM23C							9 3/16" - 233mm	14D - 21.5 x 25.1
V6 2.8L	88-89	EJ-GM23A							9 1/4" - 234mm	14D - 21.5 x 25.1
V6 3.0L	87-88	EJ-GM22E							8 1/2" - 216mm	14D - 21.5 x 25.1
V6 3.1L	89	EJ-GM23A							9 1/4" - 234mm	14D - 21.5 x 25.1
<b>CADILLAC - AUTOMÓVIL</b>										
<b>Cimarron</b>										
L4 2.0L	83-86	EJ-GM22E							8 1/2" - 216mm	14D - 21.5 x 25.1
V6 2.8L	85-86	EJ-GM23C							9 3/16" - 233mm	14D - 21.5 x 25.1
V6 2.8L	85-87	EJ-GM23A							9 1/4" - 234mm	14D - 21.5 x 25.1
<b>CHEVROLET - AUTOMÓVIL</b>										
<b>Astra</b>										
L4 1.8L DOHC, 16V, 5 Vel.	01-03	EJ-GM21A				X	EC-GM21F	48	8 1/16" - 205mm	14D - 15.7 x 18.7
L4 2.0L OHC, 5 Vel.	04-06	EJ-GM21F				X	EC-GM21F	48	8 1/16" - 205mm	14D - 15.7 x 18.7
L4 2.2L DOHC, 16V, 5 Vel.	01-03	EJ-GM23K				X	EC-GM23K	ND	9" - 229mm	14D - 21.5 x 25.1
L4 2.4L OHC, 5 Vel.	04-06	EJ-GM23N				X	EC-GM23K	ND	9" - 229mm	14D - 21.5 x 25.1
<b>Aveo</b>										
L4 1.6L DOHC	08->	EJ-GM22F							8 7/16" - 211mm	24D - 18.3 x 20.7
<b>Beretta</b>										
L4 2.0L	87-89	EJ-GM22E							8 1/2" - 216mm	14D - 21.5 x 25.1
L4 2.2L	90-94	EJ-GM22E							8 1/2" - 216mm	14D - 21.5 x 25.1
L4 2.3L	90-92	EJ-GM23A							9 1/4" - 234mm	14D - 21.5 x 25.1
V6 2.8L	87-88	EJ-GM23A							9 1/4" - 234mm	14D - 21.5 x 25.1
V6 3.1L	90-92	EJ-GM23A							9 1/4" - 234mm	14D - 21.5 x 25.1



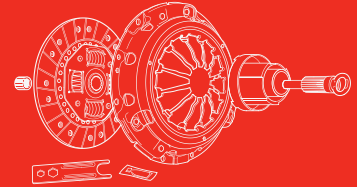

APLICACIÓN	01	NÚMERO DE PARTE	MODULAR	AUTO-AJUSTABLE	VOLANTE BI-MASA	COLL. HID. INCLUIDO	NÚMERO DE IMAGEN COLL. HID.	PÁGINA DE IMAGEN COLL. HID.	DIÁMETRO	ESTRIADO
<b>CHEVROLET - AUTOMÓVIL</b>										
<b>Camaro</b>										
V8 5.0L (302")	92	EJ-GM26C							10 7/16" - 264mm	26D - 26.5 x 29.5
V8 5.1L (310")	82-91	EJ-GM26C							10 7/16" - 264mm	26D - 26.5 x 29.5
<b>Camaro Z28</b>										
L4 2.5L 5 Vel.	83-86	EJ-GM23J							9 1/16" - 230mm	14D - 21.5 x 25.1
V6 2.8L	83-84	EJ-GM25B							9 1/16" - 231mm	14D - 1 1/8"
V6 2.8L	85-89	EJ-GM23J							9 1/16" - 230mm	14D - 21.5 x 25.1
V6 3.1L	90-92	EJ-GM23J							9 1/16" - 230mm	14D - 21.5 x 25.1
V8 5.7L (350")	96-98	EJ-GM28B							11" - 280mm	26D - 26.5 x 29.5
<b>Cavalier</b>										
L4 2.0L 5 Vel.	83-84	EJ-GM22E							8 1/2" - 216mm	14D - 21.5 x 25.1
L4 2.0L 4 Vel.	85-87	EJ-GM23C							9 3/16" - 233mm	14D - 21.5 x 25.1
L4 2.0L 5 Vel.	85-86	EJ-GM22E							8 1/2" - 216mm	14D - 21.5 x 25.1
L4 2.0L 4 Vel.	88-89	EJ-GM23C							9 3/16" - 233mm	14D - 21.5 x 25.1
L4 2.2L MPFI, OHV	90-94	EJ-GM22E							8 1/2" - 216mm	14D - 21.5 x 25.1
L4 2.2L MPFI, OHV, 5 Vel.	95-00	EJ-GM22B				X	EC-GM22B	49	8 1/2" - 216mm	14D - 21.5 x 25.1
L4 2.2L SFI, OHV, 5 Vel.	00-04	EJ-GM21D				X	EC-GM23M	49	8 7/16" - 214mm	14D - 22 x 25
L4 2.2L MPFI, DOHC, Ecotec, 5 Vel.	02-05	EJ-GM23M				X	EC-GM23M	49	8 7/8" - 225mm	14D - 21.5 x 25.1
L4 2.3L DOHC, 5 Vel.	95	EJ-GM23D				X	EC-GM22B	49	8 7/8" - 225mm	14D - 21.5 x 25.1
L4 2.4L MPFI, DOHC, 5 Vel.	95-00	EJ-GM23D				X	EC-GM22B	49	8 7/8" - 225mm	14D - 21.5 x 25.1
L4 2.4L MPFI, DOHC, 5 Vel.	00-02	EJ-GM23L				X	EC-GM23M	49	8 7/8" - 225mm	14D - 22 x 25
V6 2.8L 5 Vel.	87-92	EJ-GM23A							9 1/4" - 234mm	14D - 21.5 x 25.1
V6 2.8L 5 Vel.	93-94	EJ-GM23B				X	EC-GM23B	49	9 1/4" - 234mm	14D - 21.5 x 25.1
<b>Cavalier Z-24</b>										
V6 2.4L MPFI, 5 Vel.	95-96	EJ-GM23D				X	EC-GM22B	49	8 7/8" - 225mm	14D - 21.5 x 25.1
V6 2.8L	85-86	EJ-GM23C							9 3/16" - 233mm	14D - 21.5 x 25.1
V6 3.1L MPFI, 5 Vel.	92	EJ-GM23A							9 1/4" - 234mm	14D - 21.5 x 25.1
V6 3.1L MPFI, 5 Vel.	93-94	EJ-GM23B				X	EC-GM23B	49	9 1/4" - 234mm	14D - 21.5 x 25.1
<b>Celebrity</b>										
L4 2.5L	84-86	EJ-GM23C							9 3/16" - 233mm	14D - 21.5 x 25.1
V6 2.8L 4 Vel.	82-86	EJ-GM23C							9 3/16" - 233mm	14D - 21.5 x 25.1
V6 2.8L 5 Vel.	87-89	EJ-GM23A							9 1/4" - 234mm	14D - 21.5 x 25.1
<b>Chevelle</b>										
L4 2.4L	97-99	EJ-GM23D				X	EC-GM22B	49	8 7/8" - 225mm	14D - 21.5 x 25.1
<b>Chevy</b>										
L4 1.6L TBI/MPFI, 5 Vel.	00-03	EJ-GM20C							7 7/8" - 200mm	14D - 15.8 x 18.7
<b>Chevy C2</b>										
L4 1.6L 100HP, MPFI/SFI, 5 Vel.	04-10	EJ-GM19A							7 1/2" - 191mm	14D - 15.9 x 18.8
<b>Chevy Joy</b>										
L4 1.4L TBI/MPFI, 5 Vel.	94-02	EJ-GM19A							7 1/2" - 191mm	14D - 15.9 x 18.8
<b>Chevy Monza</b>										
L4 1.6L MPFI, 5 Vel.	96-10	EJ-GM19A							7 1/2" - 191mm	14D - 15.9 x 18.8
<b>Chevy Pop</b>										
L4 1.4L TBI/MPFI, 5 Vel.	94-02	EJ-GM19A							7 1/2" - 191mm	14D - 15.9 x 18.8



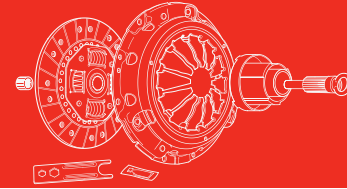

APLICACIÓN

01

NÚMERO DE PARTE

MODULAR

AUTO-AJUSTABLE

VOLANTE

BIMASA

COLL. HID. INCLUIDO

NÚMERO DE IMAGEN COLL. HID.

PÁGINA DE IMAGEN COLL. HID.

DIÁMETRO



ESTRIADO

### CHEVROLET - AUTOMÓVIL

Continuación

#### Chevy Pop

Continuación

L4 1.6L MPFI, 5 Vel.	04-10	EJ-GM19A							7 1/2" - 191mm	14D - 15.9 x 18.8
----------------------	-------	----------	--	--	--	--	--	--	----------------	-------------------

#### Chevy Sedán

L4 1.6L 100HP, SFI, 5 Vel.	09-10	EJ-GM19A							7 1/2" - 191mm	14D - 15.9 x 18.8
----------------------------	-------	----------	--	--	--	--	--	--	----------------	-------------------

#### Chevy Station Wagon

L4 1.6L MPFI, 5 Vel.	99-03	EJ-GM20C							7 7/8" - 200mm	14D - 15.8 x 18.7
----------------------	-------	----------	--	--	--	--	--	--	----------------	-------------------

#### Chevy Swing

L4 1.6L TBI/MPFI, 5 Vel.	96-03	EJ-GM19A							7 1/2" - 191mm	14D - 15.9 x 18.8
--------------------------	-------	----------	--	--	--	--	--	--	----------------	-------------------

#### Citation

L4 2.5L	80-85	EJ-GM23C							9 3/16" - 233mm	14D - 21.5 x 25.1
---------	-------	----------	--	--	--	--	--	--	-----------------	-------------------

L4 2.8L 4/5 Vel.	82-86	EJ-GM23C							9 3/16" - 233mm	14D - 21.5 x 25.1
------------------	-------	----------	--	--	--	--	--	--	-----------------	-------------------

#### Citation, X-11

V6 2.8L 4 y 5 Vel.	82-86	EJ-GM23C							9 3/16" - 233mm	14D - 21.5 x 25.1
--------------------	-------	----------	--	--	--	--	--	--	-----------------	-------------------

#### Corsa

L4 1.4L DOHC, 5 Vel.	02-03	EJ-GM20D				X	EC-GM21F	48	7 7/8" - 200mm	14D - 15.8 x 18.7
----------------------	-------	----------	--	--	--	---	----------	----	----------------	-------------------

L4 1.8L MPFI, OHC, 5 Vel.	03-09	EJ-GM21F				X	EC-GM21F	48	8 1/16" - 205mm	14D - 15.7 x 18.7
---------------------------	-------	----------	--	--	--	---	----------	----	-----------------	-------------------

#### Corsica

L4 2.0L	87-89	EJ-GM22E							8 1/2" - 216mm	14D - 21.5 x 25.1
---------	-------	----------	--	--	--	--	--	--	----------------	-------------------

L4 2.2L	90-94	EJ-GM22E							8 1/2" - 216mm	14D - 21.5 x 25.1
---------	-------	----------	--	--	--	--	--	--	----------------	-------------------

L4 2.3L	90-92	EJ-GM23A							9 1/4" - 234mm	14D - 21.5 x 25.1
---------	-------	----------	--	--	--	--	--	--	----------------	-------------------

V6 2.8L	87-88	EJ-GM23A							9 1/4" - 234mm	14D - 21.5 x 25.1
---------	-------	----------	--	--	--	--	--	--	----------------	-------------------

V6 3.1L	90-92	EJ-GM23A							9 1/4" - 234mm	14D - 21.5 x 25.1
---------	-------	----------	--	--	--	--	--	--	----------------	-------------------

#### Corvette

V8 5.7L (350") OHC	84	EJ-GM26C							10 7/16" - 264mm	26D - 26.5 x 29.5
--------------------	----	----------	--	--	--	--	--	--	------------------	-------------------

V8 5.7L (350") MPFI, 6Vel (Incluye Volante Sólido)	97-03	EJ-GM30O		X					11 11/16" - 297mm	26D - 26.65x30.2
--	-------	----------	--	---	--	--	--	--	-------------------	------------------

#### Cutlass

V6 2.8L 5 Vel.	87-90	EJ-GM23A							9 1/4" - 234mm	14D - 21.5 x 25.1
----------------	-------	----------	--	--	--	--	--	--	----------------	-------------------

#### Cutlass Eurosport

V6 2.8L 5 Vel.	87-90	EJ-GM23A							9 1/4" - 234mm	14D - 21.5 x 25.1
----------------	-------	----------	--	--	--	--	--	--	----------------	-------------------

#### HHR

L4 2.4L 5 Vel.	05->>	EJ-GM23P								
----------------	-------	----------	--	--	--	--	--	--	--	--

#### Malibu

L4 2.4L	97-99	EJ-GM23D				X	EC-GM22B	49	8 7/8" - 225mm	14D - 21.5 x 25.1
---------	-------	----------	--	--	--	---	----------	----	----------------	-------------------

#### Matiz

L4 1.0L 5Vel	03-11	EJ-GM19D							7 5/16" - 185mm	18D - 17.0 x 19.1
--------------	-------	----------	--	--	--	--	--	--	-----------------	-------------------

#### Montecarlo SS

V8 5.7L (350")	84	EJ-GM26B							10 3/8" - 263mm	10D - 1 1/8"
----------------	----	----------	--	--	--	--	--	--	-----------------	--------------

#### Optra

L4 2.0L DOHC	07-10	EJ-GM23O				X			9 1/16" - 226mm	24D - 18.1x20.46
--------------	-------	----------	--	--	--	---	--	--	-----------------	------------------

#### Saturn

L4 1.9L	91-99	EJ-GM21E							8 7/16" - 214mm	22D - 20.9x23.5
---------	-------	----------	--	--	--	--	--	--	-----------------	-----------------



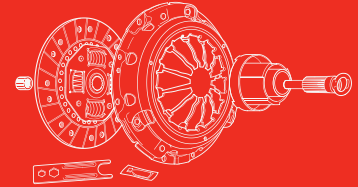

APLICACIÓN	01	NÚMERO DE PARTE	MODULAR	AUTO-AJUSTABLE	VOLANTE BI-MASA	COLL. HID. INCLUIDO	NÚMERO DE IMAGEN COLL. HID.	PÁGINA DE IMAGEN COLL. HID.	DIÁMETRO	ESTRIADO
<b>CHEVROLET/GMC-PICK-UP/CAMIONETA</b>										
<b>Astro Van</b>										
L4 2.5L	85-89	EJ-GM23J							9 1/16" - 230mm	14D - 21.5 x 25.1
<b>Blazer</b>										
L4 2.0L	83-84	EJ-GM23E							9 1/4" - 234mm	14D - 21.5 x 25.1
L4 2.5L	85-93	EJ-GM23E							9 1/4" - 234mm	14D - 21.5 x 25.1
V6 2.8L	82	EJ-GM25C							9 11/16" - 246mm	14D - 21.5 x 25.1
V6 2.8L	83-84	EJ-GM25B							9 1/16" - 231mm	14D - 1 1/8"
V6 2.8L	85-93	EJ-GM23E							9 1/4" - 234mm	14D - 21.5 x 25.1
V6 3.1L 5 Vel.	91-93	EJ-GM23E							9 1/4" - 234mm	14D - 21.5 x 25.1
V6 3.1L 5 Vel.	95	EJ-GM23F							9 1/8" - 232mm	26D - 26.5 x 29.6
V6 3.1L 5 Vel. (Con balero p/CSC)	96-98	EJ-GM23G							9 1/8" - 232mm	26D - 26.5 x 29.5
V6 3.1L 5 Vel.	96-98	EJ-GM23G3				X	EC-GM31A3	50	9 1/8" - 232mm	26D - 26.5 x 29.5
L6 4.1L (250")	81-84	EJ-GM30L							11 13/16" - 300mm	10D - 1 1/8"
V6 4.3L (260")	85-91	EJ-GM28D							11" - 280mm	10D - 1 1/8"
V6 4.3L (260")	90-93	EJ-GM28D							11" - 280mm	10D - 1 1/8"
V6 4.3L (260")	91-95	EJ-GM28E							11" - 280mm	10D - 1 1/8"
V6 4.3L (260") (Con balero p/CSC)	96-98	EJ-GM28C							11" - 280mm	10D - 1 1/8"
V6 4.3L (260")	96-98	EJ-GM28C3				X	EC-GM31A3	50	11" - 280mm	10D - 1 1/8"
V8 5.0L (302")	80-84	EJ-GM30L							11 13/16" - 300mm	10D - 1 1/8"
V8 5.0L (302")	91-95	EJ-GM28E							11" - 280mm	10D - 1 1/8"
V8 5.7L (350")	69-91	EJ-GM30L							11 13/16" - 300mm	10D - 1 1/8"
V8 6.2 (381") Diesel	82-93	EJ-GM31D							11 7/8" - 302mm	10D - 23.5 x 29
V8 7.4L (454")	73-91	EJ-GM30L							11 13/16" - 300mm	10D - 1 1/8"
V8 7.4L (454")	91-95	EJ-GM31D							11 7/8" - 302mm	10D - 23.5 x 29
<b>C-10</b>										
L6 4.1L (250")	79-84	EJ-GM30L							11 13/16" - 300mm	10D - 1 1/8"
L6 4.8L (292") 4 Vel.	70-86	EJ-GM30B							11 13/16" - 300mm	10D - 1 1/8"
L6 4.8L (292") 4 Vel.	87-97	EJ-GM28J							11" - 280mm	10D - 1 1/8"
V8 5.0L (302")	80-84	EJ-GM30L							11 13/16" - 300mm	10D - 1 1/8"
V8 5.7L (350")	69-91	EJ-GM30L							11 13/16" - 300mm	10D - 1 1/8"
V8 7.4L (454")	73-91	EJ-GM30L							11 13/16" - 300mm	10D - 1 1/8"
<b>C-15 Custom</b>										
L6 4.8L (292")	70-86	EJ-GM30B							11 13/16" - 300mm	10D - 1 1/8"
L6 4.8L (292") 4 Vel.	87-93	EJ-GM28J							11" - 280mm	10D - 1 1/8"
V8 5.7L (350") TBI, 4 Vel.	87-95	EJ-GM30B							11 13/16" - 300mm	10D - 1 1/8"
V8 5.7L (350") TBI, 4 Vel.	96-97	EJ-GM30B							11 13/16" - 300mm	10D - 1 1/8"
<b>C-20</b>										
L6 4.1L (250")	79-84	EJ-GM30L							11 13/16" - 300mm	10D - 1 1/8"
V8 5.0L (302")	80-84	EJ-GM30L							11 13/16" - 300mm	10D - 1 1/8"
V8 5.7L (350")	69-91	EJ-GM30L							11 13/16" - 300mm	10D - 1 1/8"
V8 7.4L (454")	73-91	EJ-GM30L							11 13/16" - 300mm	10D - 1 1/8"
<b>C-20 Hunter</b>										
V8 5.7L (350") 4 Vel.	87-93	EJ-GM30B							11 13/16" - 300mm	10D - 1 1/8"



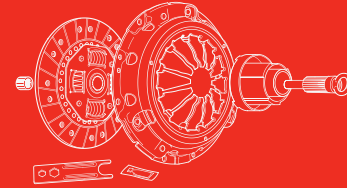

APLICACIÓN

01

NÚMERO DE PARTE

MODULAR

AUTO-AJUSTABLE

VOLANTE

BI-MASSA

COLL. HID. INCLUIDO

NÚMERO DE IMAGEN COLL. HID.

PÁGINA DE IMAGEN COLL. HID.

DIÁMETRO



ESTRIADO

### CHEVROLET/GMC-PICK-UP/CAMIONETA

Continuación

APLICACIÓN	01	NÚMERO DE PARTE	MODULAR	AUTO-AJUSTABLE	VOLANTE	BI-MASSA	COLL. HID. INCLUIDO	NÚMERO DE IMAGEN COLL. HID.	PÁGINA DE IMAGEN COLL. HID.	DIÁMETRO	ESTRIADO
<b>C-30</b>											
L6 4.1L (250")	79-84	EJ-GM30L								11 13/16" - 300mm	10D - 1 1/8"
V8 5.0L (302")	80-84	EJ-GM30L								11 13/16" - 300mm	10D - 1 1/8"
V8 5.7L (350")	69-91	EJ-GM30L								11 13/16" - 300mm	10D - 1 1/8"
V8 7.4L (454")	73-91	EJ-GM30L								11 13/16" - 300mm	10D - 1 1/8"
<b>C-30 Custom</b>											
L6 4.8L (292") 4 Vel.	63-86	EJ-GM28J								11" - 280mm	10D - 1 1/8"
L6 4.8L (292") 4 Vel.	70-86	EJ-GM30B								11 13/16" - 300mm	10D - 1 1/8"
<b>C-35 Custom</b>											
L6 4.8L (292") 4 Vel.	87-91	EJ-GM28J								11" - 280mm	10D - 1 1/8"
V8 5.7L (350") 4 Vel.	87-91	EJ-GM30B								11 13/16" - 300mm	10D - 1 1/8"
<b>C-36</b>											
V8 5.7L (350") SCPI, Vortec, 5 Vel., Transm TDET-1361	01-06	EJ-GM30H		X		X		EC-GM30H	50	11 3/4" - 298mm	10D - 1 1/8"
V8 5.7L (350") Vortec, SCPI, 5 Vel., Transm TDET-1361 Versión NO Autoajustable	01-06	EJ-GM30HE				X		EC-GM30H	50	11 3/4" - 298mm	10D - 1 1/8"
<b>C-40</b>											
L6 4.8L (292")	63-89	EJ-GM30L								11 13/16" - 300mm	10D - 1 1/8"
V8 5.7L (350")	69-89	EJ-GM30L								11 13/16" - 300mm	10D - 1 1/8"
<b>C-50</b>											
L6 4.8L (292")	63-89	EJ-GM30L								11 13/16" - 300mm	10D - 1 1/8"
V8 5.7L (350")	69-89	EJ-GM30L								11 13/16" - 300mm	10D - 1 1/8"
<b>C-1500</b>											
L6 4.1L (250")	81-84	EJ-GM30L								11 13/16" - 300mm	10D - 1 1/8"
L6 4.1L (250") TBI	94-95	EJ-GM30B								11 13/16" - 300mm	10D - 1 1/8"
V6 4.3L (260") MPFI, Vortec, Transm NVG (Con balero p/CSC)	99-05	EJ-GM30C								11" - 280mm	10D - 1 1/8"
V6 4.3L (260") MPFI, Vortec, Transm NVG	99-05	EJ-GM30C3				X		EC-GM31A3	50	11" - 280mm	10D - 1 1/8"
V6 4.3L (260") MFI, Vortec, Transm. Tremec TR-3450	99-05	EJ-GM30I				X		EC-GM30H	50	11 7/16" - 290mm	10D - 1 1/8"
L6 4.8L (292"), 4 Vel.	87-93	EJ-GM28J								11" - 280mm	10D - 1 1/8"
V8 5.0L (302")	80-84	EJ-GM30L								11 13/16" - 300mm	10D - 1 1/8"
V8 5.7L (350")	69-91	EJ-GM30L								11 13/16" - 300mm	10D - 1 1/8"
V8 5.7L (350") TBI, 4 Vel.	87-97	EJ-GM30B								11 13/16" - 300mm	10D - 1 1/8"
V8 7.4L (454")	73-91	EJ-GM30L								11 13/16" - 300mm	10D - 1 1/8"
<b>C-1500 Silverado</b>											
V6 4.3L (260"), Vortec, 5 Vel., Transm NVG (Con balero p/CSC)	99-05	EJ-GM30C								11" - 280mm	10D - 1 1/8"
V6 4.3L (260"), Vortec, 5 Vel., Transm NVG	99-05	EJ-GM30C3				X		EC-GM31A3	50	11" - 280mm	10D - 1 1/8"
V6 4.3L (260"), Vortec, 5 Vel., Transm TR-3450 (Con balero p/CSC)	99-05	EJ-GM30C								11" - 280mm	10D - 1 1/8"
V6 4.3L (260"), Vortec, 5 Vel., Transm TR-3450	99-05	EJ-GM30C3				X		EC-GM31A3	50	11" - 280mm	10D - 1 1/8"
<b>C-2500</b>											
L6 4.1L (250")	79-84	EJ-GM30L								11 13/16" - 300mm	10D - 1 1/8"
V8 5.0L (302")	80-84	EJ-GM30L								11 13/16" - 300mm	10D - 1 1/8"
V8 5.7L (350")	69-91	EJ-GM30L								11 13/16" - 300mm	10D - 1 1/8"



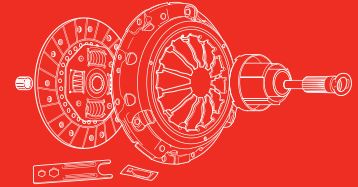

APLICACIÓN	01	NÚMERO DE PARTE	MODULAR	AUTO-AJUSTABLE	VOLANTE BI-MASA	COLL. HID. INCLUIDO	NÚMERO DE IMAGEN COLL. HID.	PÁGINA DE IMAGEN COLL. HID.	DIÁMETRO	ESTRIADO
<b>CHEVROLET/GMC-PICK-UP/CAMIONETA</b>										
<b>C-2500</b>										
V8 5.7L (350") 4 Vel.	92-00	EJ-GM30B							11 13/16" - 300mm	10D - 1 1/8"
V8 5.7L (350") 5 Vel., Transm. TR-3405-3	99-04	EJ-GM30K			X		EC-GM30H	50	11 13/16" - 300mm	10D - 1 1/8"
V8 7.4L (454")	73-91	EJ-GM30L							11 13/16" - 300mm	10D - 1 1/8"
<b>C-2500 400 SS</b>										
V8 5.7L (350"), 4 Vel.	92-00	EJ-GM30B							11 13/16" - 300mm	10D - 1 1/8"
<b>C-2500 Custom</b>										
V8 5.7L (350"), 4 Vel.	92-93	EJ-GM30B							11 13/16" - 300mm	10D - 1 1/8"
<b>C-2500 Silverado</b>										
V8 4.8L (292"), 5 Vel.	04-05	EJ-GM30M			X				11 11/16" - 297mm	10D - 23 x 29
<b>C-2500 Silverado SLX</b>										
V8 5.7L (350") 4 Vel.	94-95	EJ-GM30B							11 13/16" - 300mm	10D - 1 1/8"
V8 5.7L (350") 4 Vel. (Con balero p/CSC)	99-02	EJ-GM30E							11 13/16" - 300mm	10D - 1 1/8"
V8 5.7L (350") 4 Vel.	99-02	EJ-GM30E3			X		EC-GM31A3	50	11 13/16" - 300mm	10D - 1 1/8"
V8 5.7L (350") 5 Vel. Transm TR-3405-3	99-04	EJ-GM30K			X		EC-GM30H	50	11 13/16" - 300mm	10D - 1 1/8"
<b>C-2500 Suburban</b>										
V8 5.7L (350"), 4 Vel.	87-91	EJ-GM30B							11 13/16" - 300mm	10D - 1 1/8"
V8 5.7L (350"), 4 Vel.	96-98	EJ-GM30B							11 13/16" - 300mm	10D - 1 1/8"
<b>C-3500</b>										
L6 4.1L (250")	79-84	EJ-GM30L							11 13/16" - 300mm	10D - 1 1/8"
V8 5.0L (302")	80-84	EJ-GM30L							11 13/16" - 300mm	10D - 1 1/8"
V8 5.7L (350")	69-91	EJ-GM30L							11 13/16" - 300mm	10D - 1 1/8"
V8 5.7L (350") L Y LM, TBI, 4 Vel.	92-98	EJ-GM30B							11 13/16" - 300mm	10D - 1 1/8"
V8 5.7L (350") TBI, 4 Vel. (Con balero p/CSC)	99-02	EJ-GM30E							11 13/16" - 300mm	10D - 1 1/8"
V8 5.7L (350") TBI, 4 Vel.	99-02	EJ-GM30E3			X		EC-GM31A3	50	11 13/16" - 300mm	10D - 1 1/8"
V8 5.7L (350") SCPI, 5 Vel. (Con balero p/CSC)	01-05	EJ-GM30F	X						11 11/16" - 297mm	10D - 1 1/8"
V8 5.7L (350") Vortec, SCPI, 5 Vel.	01-05	EJ-GM30F3	X	X			EC-GM31A3	50	11 11/16" - 297mm	10D - 1 1/8"
V8 5.7L (350") Vortec, SCPI, 5 Vel., (Con balero p/CSC) Versión NO Autoajustable	01-05	EJ-GM30FE							11 11/16" - 297mm	10D - 1 1/8"
V8 5.7L (350") Vortec, SCPI, 5 Vel., Versión NO Autoajustable	01-05	EJ-GM30FE3			X		EC-GM31A3	50	11 11/16" - 297mm	10D - 1 1/8"
V8 5.7L (350") SCPI, Vortec, 5 Vel., Transm TDET-1361	01-06	EJ-GM30H	X	X			EC-GM30H	50	11 3/4" - 298mm	10D - 1 1/8"
V8 5.7L (350") Vortec, SCPI, 5 Vel, Transm TDET-1361 Versión NO Autoajustable	01-06	EJ-GM30HE			X		EC-GM30H	50	11 3/4" - 298mm	10D - 1 1/8"
V8 7.4L (454") HD, SFI, Vortec, New Venture 4500, 5 Vel. (Con balero p/CSC)	97-00	EJ-GM31A	X						12 3/16" - 310mm	10D - 1 1/8"
V8 7.4L (454") HD, SFI, Vortec, New Venture 4500, 5 Vel.	97-00	EJ-GM31A3	X	X			EC-GM31A3	50	12 3/16" - 310mm	10D - 1 1/8"
V8 8.1L (492") HD, Silverado, SFI, Vortec	01-05	EJ-GM30G3	X	X					11 3/4" - 298mm	10D - 25.8 x 31.8
<b>C-3500 Custom</b>										
V8 5.7L (350") TBI, 4 Vel.	92-98	EJ-GM30B							11 13/16" - 300mm	10D - 1 1/8"
<b>C-3500 HD</b>										
V8 7.4L (454") Vortec, Transm New Venture 4500 (Con balero p/CSC)	97-00	EJ-GM31A	X						12 3/16" - 310mm	10D - 1 1/8"
V8 7.4L (454") Vortec, Transm New Venture 4500	97-00	EJ-GM31A3	X	X			EC-GM31A3	50	12 3/16" - 310mm	10D - 1 1/8"



**MÁXIMO PODER  
DE ARRANQUE**

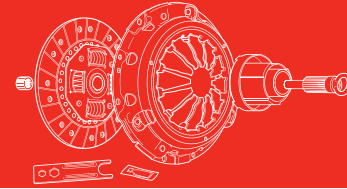

APLICACIÓN

01

NÚMERO DE PARTE

MODULAR

AUTO-AJUSTABLE

VOLANTE

BI-MASA

COLL. HID. INCLUIDO

NÚMERO DE IMAGEN COLL. HID.

PÁGINA DE IMAGEN COLL. HID.

DIÁMETRO

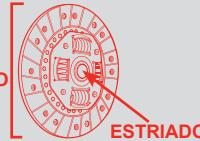

ESTRIADO

### CHEVROLET/GMC-PICK-UP/CAMIONETA

Continuación

#### C-3500 HD Silverado

Continuación

V8 7.4L (454") Vortec, SFI, 5 Vel., Transm New Venture 4500 (Con balero p/CSC)	97-00	EJ-GM31A	X					12 3/16" - 310mm	10D - 1 1/8"
V8 7.4L (454") Vortec, SFI, 5 Vel., Transm New Venture 4500	97-00	EJ-GM31A3	X	X		EC-GM31A3	50	12 3/16" - 310mm	10D - 1 1/8"
V8 8.1L (492") Vortec, SFI, 5 Vel.	01-05	EJ-GM30G3	X	X				11 3/4" - 298mm	10D - 25.8 x 31.8

#### C-4000

V8 5.7L (350") 4 Vel. (Con balero p/CSC)	96-00	EJ-GM30E						11 13/16" - 300mm	10D - 1 1/8"
V8 5.7L (350") 4 Vel.	96-00	EJ-GM30E3			X	EC-GM31A3	50	11 13/16" - 300mm	10D - 1 1/8"
V8 5.7L (350") 4 Vel. (Con balero p/CSC)	96-00	EJ-GM30J						11 13/16" - 294mm	10D - 1 1/8"
V8 5.7L (350") 4 Vel.	96-00	EJ-GM30J3			X			11 13/16" - 294mm	10D - 1 1/8"

#### Chevy Pick-Up

L4 1.6L MPFI, 5 Vel.	99-03	EJ-GM20C						7 7/8" - 200mm	14D - 15.8 x 18.7
----------------------	-------	----------	--	--	--	--	--	----------------	-------------------

#### Cheyenne

L6 4.8L (292") 4 Vel.	63-86	EJ-GM28J						11" - 280mm	10D - 1 1/8"
L6 4.8L (292") 4 Vel.	70-86	EJ-GM30B						11 13/16" - 300mm	10D - 1 1/8"
L6 4.8L (292") 4 Vel.	87-91	EJ-GM28J						11" - 280mm	10D - 1 1/8"
V8 5.7L (350") 4 Vel.	87-93	EJ-GM30B						11 13/16" - 300mm	10D - 1 1/8"
V8 5.7L (350") TBI, 4 Vel.	92-98	EJ-GM30B						11 13/16" - 300mm	10D - 1 1/8"

#### Cheyenne Custom

V8 5.7L (350") 4 Vel.	87-93	EJ-GM30B						11 13/16" - 300mm	10D - 1 1/8"
-----------------------	-------	----------	--	--	--	--	--	-------------------	--------------

#### G-10

L6 4.1L (250")	79-84	EJ-GM30L						11 13/16" - 300mm	10D - 1 1/8"
V8 5.0L (302")	81-84	EJ-GM30L						11 13/16" - 300mm	10D - 1 1/8"
V8 5.7L (350")	72-84	EJ-GM30L						11 13/16" - 300mm	10D - 1 1/8"
V8 7.4L (454")	73-84	EJ-GM30L						11 13/16" - 300mm	10D - 1 1/8"

#### G-20

L6 4.1L (250")	79-84	EJ-GM30L						11 13/16" - 300mm	10D - 1 1/8"
V8 5.0L (302")	81-84	EJ-GM30L						11 13/16" - 300mm	10D - 1 1/8"
V8 5.7L (350")	72-84	EJ-GM30L						11 13/16" - 300mm	10D - 1 1/8"
V8 7.4L (454")	73-84	EJ-GM30L						11 13/16" - 300mm	10D - 1 1/8"

#### G-30

L6 4.1L (250")	79-84	EJ-GM30L						11 13/16" - 300mm	10D - 1 1/8"
V8 5.0L (302")	81-84	EJ-GM30L						11 13/16" - 300mm	10D - 1 1/8"
V8 5.7L (350")	72-84	EJ-GM30L						11 13/16" - 300mm	10D - 1 1/8"
V8 7.4L (454")	73-84	EJ-GM30L						11 13/16" - 300mm	10D - 1 1/8"

#### G-1500

L6 4.1L (250")	79-84	EJ-GM30L						11 13/16" - 300mm	10D - 1 1/8"
V8 5.0L (302")	81-84	EJ-GM30L						11 13/16" - 300mm	10D - 1 1/8"
V8 5.7L (350")	72-84	EJ-GM30L						11 13/16" - 300mm	10D - 1 1/8"
V8 7.4L (454")	73-84	EJ-GM30L						11 13/16" - 300mm	10D - 1 1/8"

#### G-2500

L6 4.1L (250")	79-84	EJ-GM30L						11 13/16" - 300mm	10D - 1 1/8"
V8 5.0L (302")	81-84	EJ-GM30L						11 13/16" - 300mm	10D - 1 1/8"
V8 5.7L (350")	72-84	EJ-GM30L						11 13/16" - 300mm	10D - 1 1/8"



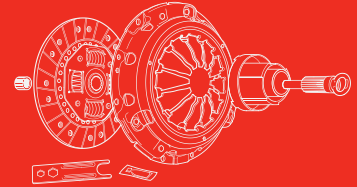

APLICACIÓN	01	NÚMERO DE PARTE	MODULAR	AUTO-AJUSTABLE	VOLANTE BI-MASA	COLL. HID. INCLUIDO	NÚMERO DE IMAGEN COLL. HID.	PÁGINA DE IMAGEN COLL. HID.	DIÁMETRO	ESTRIADO
<b>CHEVROLET/GMC-PICK-UP/CAMIONETA</b>										
<b>G-2500</b>										
V8 7.4L (454")	73-84	EJ-GM30L							11 13/16" - 300mm	10D - 1 1/8"
<b>G-3500</b>										
L6 4.1L (250")	79-84	EJ-GM30L							11 13/16" - 300mm	10D - 1 1/8"
V8 5.0L (302")	81-84	EJ-GM30L							11 13/16" - 300mm	10D - 1 1/8"
V8 5.7L (350")	72-84	EJ-GM30L							11 13/16" - 300mm	10D - 1 1/8"
V8 7.4L (454")	73-84	EJ-GM30L							11 13/16" - 300mm	10D - 1 1/8"
<b>Jimmy</b>										
L4 2.0L	83-84	EJ-GM23E							9 1/4" - 234mm	14D - 21.5 x 25.1
L4 2.5L	85-93	EJ-GM23E							9 1/4" - 234mm	14D - 21.5 x 25.1
V6 2.8L	83-84	EJ-GM25B							9 1/16" - 231mm	14D - 1 1/8"
V6 2.8L	85-93	EJ-GM23E							9 1/4" - 234mm	14D - 21.5 x 25.1
L6 4.1L (250")	79-84	EJ-GM30L							11 13/16" - 300mm	10D - 1 1/8"
V6 4.3L (261")	85-93	EJ-GM28D							11" - 280mm	10D - 1 1/8"
V6 4.3L (261")	91-95	EJ-GM28B							11" - 280mm	26D - 26.5 x 29.5
V6 4.3L (260")	91-95	EJ-GM28E							11" - 280mm	10D - 1 1/8"
V6 4.3L (260") (Con balero p/CSC)	96-98	EJ-GM28C							11" - 280mm	10D - 1 1/8"
V6 4.3L (260")	96-98	EJ-GM28C3			X		EC-GM31A3	50	11" - 280mm	10D - 1 1/8"
V8 5.0L (302")	80-84	EJ-GM30L							11 13/16" - 300mm	10D - 1 1/8"
V8 5.0L (302")	91-95	EJ-GM28E							11" - 280mm	10D - 1 1/8"
V8 5.7L (350")	69-91	EJ-GM30L							11 13/16" - 300mm	10D - 1 1/8"
V8 6.2L (381") Diesel	82-93	EJ-GM31D							11 7/8" - 302mm	10D - 23.5 x 29
V8 7.4L (454")	73-91	EJ-GM31D							11 7/8" - 302mm	10D - 23.5 x 29
<b>K-10</b>										
L6 4.1L (250")	79-84	EJ-GM30L							11 13/16" - 300mm	10D - 1 1/8"
V8 5.0L (302")	80-84	EJ-GM30L							11 13/16" - 300mm	10D - 1 1/8"
V8 5.7L (350")	69-91	EJ-GM30L							11 13/16" - 300mm	10D - 1 1/8"
V8 7.4L (454")	73-91	EJ-GM30L							11 13/16" - 300mm	10D - 1 1/8"
<b>K-20</b>										
L6 4.1L (250")	79-84	EJ-GM30L							11 13/16" - 300mm	10D - 1 1/8"
V8 5.0L (302")	80-84	EJ-GM30L							11 13/16" - 300mm	10D - 1 1/8"
V8 5.7L (350")	69-91	EJ-GM30L							11 13/16" - 300mm	10D - 1 1/8"
V8 7.4L (454")	73-91	EJ-GM30L							11 13/16" - 300mm	10D - 1 1/8"
<b>K-30</b>										
L6 4.1L (250")	79-84	EJ-GM30L							11 13/16" - 300mm	10D - 1 1/8"
V8 5.0L (302")	80-84	EJ-GM30L							11 13/16" - 300mm	10D - 1 1/8"
V8 5.7L (350")	69-91	EJ-GM30L							11 13/16" - 300mm	10D - 1 1/8"
V8 7.4L (454")	73-91	EJ-GM30L							11 13/16" - 300mm	10D - 1 1/8"
<b>K-1500</b>										
L6 4.1L (250")	81-84	EJ-GM30L							11 13/16" - 300mm	10D - 1 1/8"
V8 5.0L (302")	80-84	EJ-GM30L							11 13/16" - 300mm	10D - 1 1/8"
V8 5.7L (350")	69-91	EJ-GM30L							11 13/16" - 300mm	10D - 1 1/8"
<b>K-2500</b>										
L6 4.1L (250")	81-84	EJ-GM30L							11 13/16" - 300mm	10D - 1 1/8"



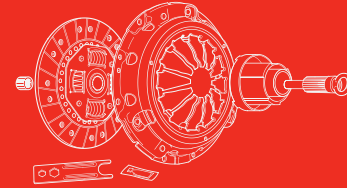

APLICACIÓN

01

NÚMERO DE PARTE

MODULAR

AUTO-AJUSTABLE

VOLANTE BI-MASA

COLL. HID. INCLUIDO

NÚMERO DE IMAGEN COLL. HID.

PÁGINA DE IMAGEN COLL. HID.

DIÁMETRO

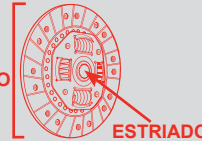

ESTRIADO

### CHEVROLET/GMC-PICK-UP/CAMIONETA

Continuación

#### K-2500

Continuación

V8 5.0L (302")	80-84	EJ-GM30L							11 13/16" - 300mm	10D - 1 1/8"
V8 5.7L (350")	69-91	EJ-GM30L							11 13/16" - 300mm	10D - 1 1/8"

#### K-3500

L6 4.1L (250")	81-84	EJ-GM30L							11 13/16" - 300mm	10D - 1 1/8"
V8 5.0L (302")	80-84	EJ-GM30L							11 13/16" - 300mm	10D - 1 1/8"
V8 5.7L (350")	69-91	EJ-GM30L							11 13/16" - 300mm	10D - 1 1/8"

#### Luv

L4 1.8L	80-82	EJ-GM22A							8 1/2" - 216mm	24D - 23.0 x 25.6
L4 2.2L 5 Vel. (Volante Tipo Caja)	99-05	EJ-GM22D							8 7/16" - 215mm	24D - 23.0 x 25.6
L4 2.2L 5 Vel.	99-05	EJ-GM22A2							8 7/16" - 215mm	24D - 23.0 x 25.6
L4 2.3L 5 Vel.	98-99	EJ-GM22A							8 1/2" - 216mm	24D - 23.0 x 25.6

#### Meriva

L4 1.8L MPFI	03-08	EJ-GM21F				X	EC-GM21F	48	8 1/16" - 205mm	14D - 15.7 x 18.7
--------------	-------	----------	--	--	--	---	----------	----	-----------------	-------------------

#### P-10

L6 4.1L (250")	81-84	EJ-GM30L							11 13/16" - 300mm	10D - 1 1/8"
V8 5.0L (302")	80-84	EJ-GM30L							11 13/16" - 300mm	10D - 1 1/8"
V8 5.7L (350")	72-91	EJ-GM30L							11 13/16" - 300mm	10D - 1 1/8"
V8 7.4L (454")	73-91	EJ-GM30L							11 13/16" - 300mm	10D - 1 1/8"

#### P-20

L6 4.1L (250")	79-84	EJ-GM30L							11 13/16" - 300mm	10D - 1 1/8"
V8 5.0L (302")	80-84	EJ-GM30L							11 13/16" - 300mm	10D - 1 1/8"
V8 5.7L (350")	69-91	EJ-GM30L							11 13/16" - 300mm	10D - 1 1/8"
V8 7.4L (454")	73-91	EJ-GM30L							11 13/16" - 300mm	10D - 1 1/8"

#### P-30

L6 4.1L (250")	81-84	EJ-GM30L							11 13/16" - 300mm	10D - 1 1/8"
V8 5.0L (302")	80-84	EJ-GM30L							11 13/16" - 300mm	10D - 1 1/8"
V8 5.7L (350")	72-91	EJ-GM30L							11 13/16" - 300mm	10D - 1 1/8"
V8 5.7L (350") 4 Vel.	87-96	EJ-GM30D							11 13/16" - 300mm	10D - 11/8"
V8 5.7L (350") 4 Vel.	97-98	EJ-GM30B							11 13/16" - 300mm	10D - 1 1/8"
V8 5.7L (350") 4 Vel. (Con balero p/CSC)	97-03	EJ-GM30E							11 13/16" - 300mm	10D - 1 1/8"
V8 5.7L (350") 4 Vel.	97-03	EJ-GM30E3				X	EC-GM31A3	50	11 13/16" - 300mm	10D - 1 1/8"
V8 7.4L (454")	73-91	EJ-GM30L							11 13/16" - 300mm	10D - 1 1/8"

#### R-10

L6 4.1L (250")	81-84	EJ-GM30L							11 13/16" - 300mm	10D - 1 1/8"
V8 5.0L (302")	80-84	EJ-GM30L							11 13/16" - 300mm	10D - 1 1/8"
V8 5.7L (350")	69-91	EJ-GM30L							11 13/16" - 300mm	10D - 1 1/8"
V8 7.4L (454")	73-91	EJ-GM30L							11 13/16" - 300mm	10D - 1 1/8"

#### R-20

L6 4.1L (250")	79-84	EJ-GM30L							11 13/16" - 300mm	10D - 1 1/8"
V8 5.0L (302")	80-84	EJ-GM30L							11 13/16" - 300mm	10D - 1 1/8"
V8 5.7L (350")	69-91	EJ-GM30L							11 13/16" - 300mm	10D - 1 1/8"
V8 7.4L (454")	73-91	EJ-GM30L							11 13/16" - 300mm	10D - 1 1/8"



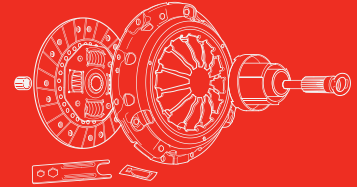

APLICACIÓN	01	NÚMERO DE PARTE	MODULAR	AUTO-AJUSTABLE	VOLANTE BI-MASA	COLL. HID. INCLUIDO	NÚMERO DE IMAGEN COLL. HID.	PÁGINA DE IMAGEN COLL. HID.	DIÁMETRO	ESTRIADO
------------	----	-----------------	---------	----------------	-----------------	---------------------	-----------------------------	-----------------------------	----------	----------

**CHEVROLET/GMC-PICK-UP/CAMIONETA** Continuación

<b>R-30</b>										
L6 4.1L (250")	79-84	EJ-GM30L							11 13/16" - 300mm	10D - 1 1/8"
V8 5.0L (302")	80-84	EJ-GM30L							11 13/16" - 300mm	10D - 1 1/8"
V8 5.7L (350")	69-91	EJ-GM30L							11 13/16" - 300mm	10D - 1 1/8"
V8 7.4L (454")	73-91	EJ-GM30L							11 13/16" - 300mm	10D - 1 1/8"
<b>R-1500</b>										
L6 4.1L (250")	79-84	EJ-GM30L							11 13/16" - 300mm	10D - 1 1/8"
V8 5.0L (302")	80-84	EJ-GM30L							11 13/16" - 300mm	10D - 1 1/8"
V8 5.7L (350")	69-91	EJ-GM30L							11 13/16" - 300mm	10D - 1 1/8"
<b>R-2500</b>										
L6 4.1L (250")	79-84	EJ-GM30L							11 13/16" - 300mm	10D - 1 1/8"
V8 5.0L (302")	80-84	EJ-GM30L							11 13/16" - 300mm	10D - 1 1/8"
V8 5.7L (350")	69-91	EJ-GM30L							11 13/16" - 300mm	10D - 1 1/8"
<b>R-3500</b>										
L6 4.1L (250")	79-84	EJ-GM30L							11 13/16" - 300mm	10D - 1 1/8"
V8 5.0L (302")	80-84	EJ-GM30L							11 13/16" - 300mm	10D - 1 1/8"
V8 5.7L (350")	69-91	EJ-GM30L							11 13/16" - 300mm	10D - 1 1/8"
<b>S-10</b>										
L4 2.0L	83-84	EJ-GM23E							9 1/4" - 234mm	14D - 21.5 x 25.1
L4 2.2L FI, OHV, 5 Vel.	96	EJ-GM23F							9 1/8" - 232mm	26D - 26.5 x 29.6
L4 2.2L (Con balero p/CSC)	96-04	EJ-GM23G							9 1/8" - 232mm	26D - 26.5 x 29.5
L4 2.2L	96-04	EJ-GM23G3			X	EC-GM31A3	50		9 1/8" - 232mm	26D - 26.5 x 29.5
L4 2.4L MPFI	01	EJ-GM23N			X	EC-GM23K	ND		9" - 229mm	14D - 21.5 x 25.1
L4 2.5L	85-93	EJ-GM23E							9 1/4" - 234mm	14D - 21.5 x 25.1
V6 2.8L	82	EJ-GM25C							9 11/16" - 246mm	14D - 21.5 x 25.1
V6 2.8L	83-84	EJ-GM25B							9 1/16" - 231mm	14D - 1 1/8"
V6 2.8L	85-93	EJ-GM23E							9 1/4" - 234mm	14D - 21.5 x 25.1
V6 3.1L TBI, 5 Vel., TR-2250	91-95	EJ-GM23E							9 1/4" - 234mm	14D - 21.5 x 25.1
V6 4.3L (260")	94-95	EJ-GM28D							11" - 280mm	10D - 1 1/8"
<b>S-15</b>										
L4 2.0L	83-84	EJ-GM23E							9 1/4" - 234mm	14D - 21.5 x 25.1
L4 2.5L	85-93	EJ-GM23E							9 1/4" - 234mm	14D - 21.5 x 25.1
V6 2.8L	83-84	EJ-GM25B							9 1/16" - 231mm	14D - 1 1/8"
V6 2.8L	85-93	EJ-GM23E							9 1/4" - 234mm	14D - 21.5 x 25.1
V6 4.3L (261")	90-93	EJ-GM28D							11" - 280mm	10D - 1 1/8"
<b>Safari Van</b>										
L4 2.5L	85-89	EJ-GM23J							9 1/16" - 230mm	14D - 21.5 x 25.1
<b>Sierra</b>										
L6 4.1L (250")	81-84	EJ-GM30L							11 13/16" - 300mm	10D - 1 1/8"
V6 4.3L (260")	85-91	EJ-GM28D							11" - 280mm	10D - 1 1/8"
V6 4.3L (260")	91-95	EJ-GM28E							11" - 280mm	10D - 1 1/8"
V6 4.3L (260") (Con balero p/CSC)	96-98	EJ-GM28C							11" - 280mm	10D - 1 1/8"
V6 4.3L (260")	96-98	EJ-GM28C3			X	EC-GM31A3	50		11" - 280mm	10D - 1 1/8"
V8 5.0L (302")	80-84	EJ-GM30L							11 13/16" - 300mm	10D - 1 1/8"



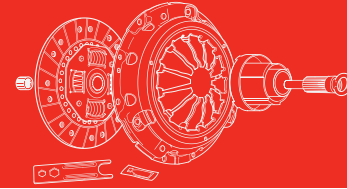

APLICACIÓN

01

NÚMERO DE PARTE

MODULAR

AUTO-AJUSTABLE

VOLANTE

BI-MASA

COLL. HID. INCLUIDO

NÚMERO DE IMAGEN COLL. HID.

PÁGINA DE IMAGEN COLL. HID.

DIÁMETRO



ESTRIADO

### CHEVROLET/GMC-PICK-UP/CAMIONETA

Continuación

Sierra										Continuación	
V8 5.0L (302")	91-95	EJ-GM28E								11" - 280mm	10D - 1 1/8"
V8 5.7L (350")	69-91	EJ-GM30L								11 13/16" - 300mm	10D - 1 1/8"
V8 6.2L (381") Diesel	82-93	EJ-GM31D								11 7/8" - 302mm	10D - 23.5 x 29
V8 7.4L (454")	73-91	EJ-GM30L								11 13/16" - 300mm	10D - 1 1/8"
V8 7.4L (454")	91-95	EJ-GM31D								11 7/8" - 302mm	10D - 23.5 x 29
Silverado										Continuación	
L6 4.1L (250")	79-84	EJ-GM30L								11 13/16" - 300mm	10D - 1 1/8"
V6 4.3L (260")	85-91	EJ-GM28D								11" - 280mm	10D - 1 1/8"
V6 4.3L (260")	91-95	EJ-GM28E								11" - 280mm	10D - 1 1/8"
V6 4.3L (260") (Con balero p/CSC)	96-99	EJ-GM28C								11" - 280mm	10D - 1 1/8"
V6 4.3L (260")	96-99	EJ-GM28C3			X		EC-GM31A3	50		11" - 280mm	10D - 1 1/8"
V8 5.0L (302")	80-84	EJ-GM30L								11 13/16" - 300mm	10D - 1 1/8"
V8 5.0L (302")	91-95	EJ-GM28E								11" - 280mm	10D - 1 1/8"
V8 5.7L (350")	69-91	EJ-GM30L								11 13/16" - 300mm	10D - 1 1/8"
V8 6.2L (381") Diesel	82-93	EJ-GM31D								11 7/8" - 302mm	10D - 23.5 x 29
V8 7.4L (454")	91-95	EJ-GM31D								11 7/8" - 302mm	10D - 23.5 x 29
V8 7.4L (454")	73-91	EJ-GM30L								11 13/16" - 300mm	10D - 1 1/8"
Silverado SLX											
V8 5.7L (350") TBI, 4 Vel.	96-98	EJ-GM30B								11 13/16" - 300mm	10D - 1 1/8"
Sonoma											
L4 2.0L	83-84	EJ-GM23E								9 1/4" - 234mm	14D - 21.5 x 25.1
L4 2.5L	85-93	EJ-GM23E								9 1/4" - 234mm	14D - 21.5 x 25.1
V6 2.8L	83-84	EJ-GM25B								9 1/16" - 231mm	14D - 1 1/8"
V6 2.8L	85-93	EJ-GM23E								9 1/4" - 234mm	14D - 21.5 x 25.1
V6 4.3L (260")	90-93	EJ-GM28D								11" - 280mm	10D - 1 1/8"
T-10											
L4 2.0L	83-84	EJ-GM23E								9 1/4" - 234mm	14D - 21.5 x 25.1
L4 2.5L	85-93	EJ-GM23E								9 1/4" - 234mm	14D - 21.5 x 25.1
V6 2.8L	82	EJ-GM25C								9 11/16" - 246mm	14D - 21.5 x 25.1
V6 2.8L	83-84	EJ-GM25B								9 1/16" - 231mm	14D - 1 1/8"
V6 2.8L	85-93	EJ-GM23E								9 1/4" - 234mm	14D - 21.5 x 25.1
V6 4.3L (260")	90-93	EJ-GM28D								11" - 280mm	10D - 1 1/8"
T-15											
L4 2.0L	83-84	EJ-GM23E								9 1/4" - 234mm	14D - 21.5 x 25.1
L4 2.5L	85-93	EJ-GM23E								9 1/4" - 234mm	14D - 21.5 x 25.1
V6 2.8L	83-84	EJ-GM25B								9 1/16" - 231mm	14D - 1 1/8"
V6 2.8L	85-93	EJ-GM23E								9 1/4" - 234mm	14D - 21.5 x 25.1
V6 4.3L (260")	90-93	EJ-GM28D								11" - 280mm	10D - 1 1/8"
Tahoe											
L6 4.1L (250")	79-84	EJ-GM30L								11 13/16" - 300mm	10D - 1 1/8"
V6 4.3L (260")	85-91	EJ-GM28D								11" - 280mm	10D - 1 1/8"
V6 4.3L (260")	91-95	EJ-GM28E								11" - 280mm	10D - 1 1/8"
V6 4.3L (260") (Con balero p/CSC)	96-98	EJ-GM28C								11" - 280mm	10D - 1 1/8"



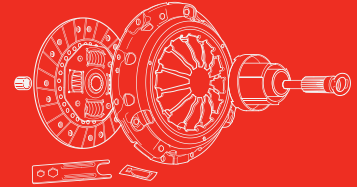

APLICACIÓN	01	NÚMERO DE PARTE	MODULAR	AUTO-AJUSTABLE	VOLANTE BI-MASA	COLL. HID. INCLUIDO	NÚMERO DE IMAGEN COLL. HID.	PÁGINA DE IMAGEN COLL. HID.	DIÁMETRO	ESTRIADO
<b>CHEVROLET/GMC-PICK-UP/CAMIONETA</b>										
<b>Tahoe</b>										
V6 4.3L (260")	96-98	EJ-GM28C3				X	EC-GM31A3	50	11" - 280mm	10D - 1 1/8"
V8 5.0L (302")	80-84	EJ-GM30L							11 13/16" - 300mm	10D - 1 1/8"
V8 5.0L (302")	91-95	EJ-GM28E							11" - 280mm	10D - 1 1/8"
V8 5.7L (350")	69-91	EJ-GM30L							11 13/16" - 300mm	10D - 1 1/8"
V8 6.2L (381") Diesel	82-93	EJ-GM31D							11 7/8" - 302mm	10D - 23.5 x 29
V8 7.4L (454")	91-95	EJ-GM31D							11 7/8" - 302mm	10D - 23.5 x 29
V8 7.4L (454")	73-91	EJ-GM30L							11 13/16" - 300mm	10D - 1 1/8"
<b>Topkick</b>										
L6 4.8L (292")	63-89	EJ-GM30L							11 13/16" - 300mm	10D - 1 1/8"
V8 5.7L (350")	69-89	EJ-GM30L							11 13/16" - 300mm	10D - 1 1/8"
<b>Tornado</b>										
L4 1.8L OHC, 5 Vel.	04-10	EJ-GM21F				X	EC-GM21F	48	8 1/16" - 205mm	14D - 15.7 x 18.7
<b>Tracker</b>										
L4 1.6L OHV, 5 Vel.	89-95	EJ-GE20A							7 7/8" - 200mm	20D - 20.0 x 22.5
L4 2.0L MPFI, DOHC, 5 Vel.	99-03	EJ-GE20C							7 7/8" - 200mm	20D - 20.0 x 22.5
<b>V-10</b>										
L6 4.1L (250")	81-84	EJ-GM30L							11 13/16" - 300mm	10D - 1 1/8"
V8 5.0L (302")	80-84	EJ-GM30L							11 13/16" - 300mm	10D - 1 1/8"
V8 5.7L (350")	69-91	EJ-GM30L							11 13/16" - 300mm	10D - 1 1/8"
V8 7.4L (454")	73-91	EJ-GM30L							11 13/16" - 300mm	10D - 1 1/8"
<b>V-20</b>										
L6 4.1L (250")	79-84	EJ-GM30L							11 13/16" - 300mm	10D - 1 1/8"
V8 5.0L (302")	80-84	EJ-GM30L							11 13/16" - 300mm	10D - 1 1/8"
V8 5.7L (350")	69-91	EJ-GM30L							11 13/16" - 300mm	10D - 1 1/8"
V8 7.4L (454")	73-91	EJ-GM30L							11 13/16" - 300mm	10D - 1 1/8"
<b>V-30</b>										
L6 4.1L (250")	79-84	EJ-GM30L							11 13/16" - 300mm	10D - 1 1/8"
V8 5.0L (302")	80-84	EJ-GM30L							11 13/16" - 300mm	10D - 1 1/8"
V8 5.7L (350")	69-91	EJ-GM30L							11 13/16" - 300mm	10D - 1 1/8"
V8 7.4L (454")	73-91	EJ-GM30L							11 13/16" - 300mm	10D - 1 1/8"
<b>V-1500</b>										
L6 4.1L (250")	79-84	EJ-GM30L							11 13/16" - 300mm	10D - 1 1/8"
V8 5.0L (302")	80-84	EJ-GM30L							11 13/16" - 300mm	10D - 1 1/8"
V8 5.7L (350")	69-91	EJ-GM30L							11 13/16" - 300mm	10D - 1 1/8"
<b>V-2500</b>										
L6 4.1L (250")	79-84	EJ-GM30L							11 13/16" - 300mm	10D - 1 1/8"
V8 5.0L (302")	80-84	EJ-GM30L							11 13/16" - 300mm	10D - 1 1/8"
V8 5.7L (350")	69-91	EJ-GM30L							11 13/16" - 300mm	10D - 1 1/8"
<b>V-3500</b>										
L6 4.1L (250")	79-84	EJ-GM30L							11 13/16" - 300mm	10D - 1 1/8"
V8 5.0L (302")	80-84	EJ-GM30L							11 13/16" - 300mm	10D - 1 1/8"
V8 5.7L (350")	69-91	EJ-GM30L							11 13/16" - 300mm	10D - 1 1/8"

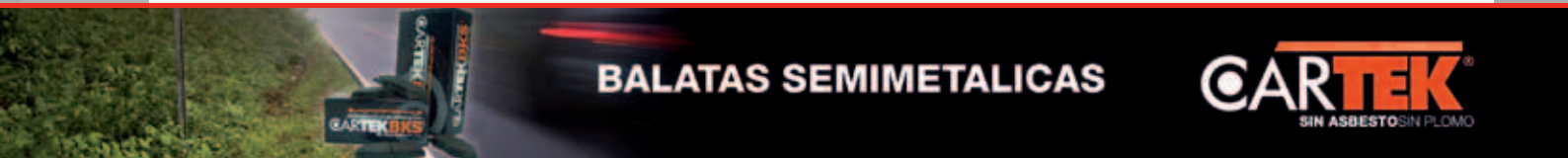

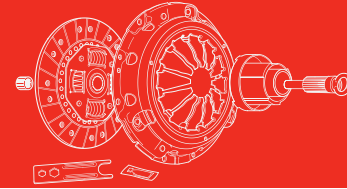

APLICACIÓN

01

NÚMERO DE PARTE

MODULAR

AUTO-AJUSTABLE

VOLANTE

BI-MASA

COLL. HID. INCLUIDO

NÚMERO DE IMAGEN COLL. HID.

PÁGINA DE IMAGEN COLL. HID.

DIÁMETRO

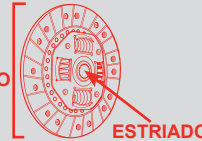

ESTRIADO

### CHEVROLET/GMC-PICK-UP/CAMIONETA

Continuación

Van										
L6 4.1L (250")	79-84	EJ-GM30L							11 13/16" - 300mm	10D - 1 1/8"
V8 5.0L (302")	80-84	EJ-GM30L							11 13/16" - 300mm	10D - 1 1/8"
V8 5.7L (350")	72-84	EJ-GM30L							11 13/16" - 300mm	10D - 1 1/8"
V8 7.4L (454")	73-84	EJ-GM30L							11 13/16" - 300mm	10D - 1 1/8"
Yukon										
L6 4.1L (250")	79-84	EJ-GM30L							11 13/16" - 300mm	10D - 1 1/8"
V6 4.3L (261")	85-91	EJ-GM28D							11" - 280mm	10D - 1 1/8"
V6 4.3L (261")	91-95	EJ-GM28E							11" - 280mm	10D - 1 1/8"
V6 4.3L (261") (Con balero p/CSC)	96-98	EJ-GM28C							11" - 280mm	10D - 1 1/8"
V6 4.3L (261")	96-98	EJ-GM28C3			X	EC-GM31A3	50		11" - 280mm	10D - 1 1/8"
V8 5.0L (302")	80-84	EJ-GM30L							11 13/16" - 300mm	10D - 1 1/8"
V8 5.0L (302")	91-95	EJ-GM28E							11" - 280mm	10D - 1 1/8"
V8 5.7L (350")	69-91	EJ-GM30L							11 13/16" - 300mm	10D - 1 1/8"
V8 6.2L (381") Diesel	82-93	EJ-GM31D							11 7/8" - 302mm	10D - 23.5 x 29
V8 7.4L (454")	91-95	EJ-GM31D							11 7/8" - 302mm	10D - 23.5 x 29
V8 7.4L (454")	73-91	EJ-GM30L							11 13/16" - 300mm	10D - 1 1/8"
Zafira XE										
L4 1.8L 16V	02-06	EJ-GM21A			X	EC-GM21F	48		8 1/16" - 205mm	14D - 15.7 x 18.7

### CHEVROLET / GMC - MICROBÚS

Vanette										
V8 5.7L (350") 4 Vel. (Con balero p/CSC)	97	EJ-GM30E							11 13/16" - 300mm	10D - 1 1/8"
V8 5.7L (350") 4 Vel.	97	EJ-GM30E3			X	EC-GM31A3	50		11 13/16" - 300mm	10D - 1 1/8"
V8 5.7L (350") 4 Vel. (Con balero p/CSC)	97	EJ-GM30J							11 13/16" - 294mm	10D - 1 1/8"
V8 5.7L (350") 4 Vel.	97	EJ-GM30J3			X				11 13/16" - 294mm	10D - 1 1/8"
Vanette P-300										
L6 4.8L (292") 4 Vel.	63-86	EJ-GM28J							11" - 280mm	10D - 1 1/8"
V8 5.7L (350") 4 Vel.	85-96	EJ-GM30B							11 13/16" - 300mm	10D - 1 1/8"
V8 5.7L (350") 4 Vel. (Con balero p/CSC)	97->>	EJ-GM30E							11 13/16" - 300mm	10D - 1 1/8"
V8 5.7L (350") 4 Vel.	97->>	EJ-GM30E3			X	EC-GM31A3	50		11 13/16" - 300mm	10D - 1 1/8"
V8 5.7L (350") 4 Vel. (Con balero p/CSC)	97->>	EJ-GM30J							11 13/16" - 294mm	10D - 1 1/8"
V8 5.7L (350") 4 Vel.	97->>	EJ-GM30J3			X				11 13/16" - 294mm	10D - 1 1/8"

### CHEVROLET / GMC - CAMIÓN

C-60										
L6 4.8L (292")	63-89	EJ-GM30L							11 13/16" - 300mm	10D - 1 1/8"
L6 4.8L (292") 4 Vel.	70-85	EJ-GM30B							11 13/16" - 300mm	10D - 1 1/8"
V8 5.7L (350")	69-89	EJ-GM30L							11 13/16" - 300mm	10D - 1 1/8"
C-70										
L6 4.8L (292")	63-89	EJ-GM30L							11 13/16" - 300mm	10D - 1 1/8"
V8 5.7L (350")	69-89	EJ-GM30L							11 13/16" - 300mm	10D - 1 1/8"
C-5500										
L6 4.8L (292")	63-89	EJ-GM30L							11 13/16" - 300mm	10D - 1 1/8"
V8 5.7L (350")	69-89	EJ-GM30L							11 13/16" - 300mm	10D - 1 1/8"



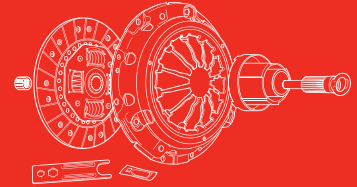

APLICACIÓN	01	NÚMERO DE PARTE	MODULAR	AUTO-AJUSTABLE	VOLANTE BI-MASA	COLL. HID. INCLUIDO	NÚMERO DE IMAGEN COLL. HID.	PÁGINA DE IMAGEN COLL. HID.	DIÁMETRO	ESTRIADO
<b>CHEVROLET / GMC - CAMIÓN</b>										
<b>C-6500</b>										
L6 4.8L (292")	63-89	EJ-GM30L							11 13/16" - 300mm	10D - 1 1/8"
V8 5.7L (350")	69-89	EJ-GM30L							11 13/16" - 300mm	10D - 1 1/8"
<b>C-7500</b>										
L6 4.8L (292")	63-89	EJ-GM30L							11 13/16" - 300mm	10D - 1 1/8"
V8 5.7L (350")	69-89	EJ-GM30L							11 13/16" - 300mm	10D - 1 1/8"
<b>Kodiak Gasolina</b>										
L6 4.8L (292")	63-89	EJ-GM30L							11 13/16" - 300mm	10D - 1 1/8"
<b>CHRYSLER / DODGE - AUTOMÓVIL</b>										
<b>Aries</b>										
L4 2.2L	81-89	EJ-D22A							8 1/2" - 216mm	18D - 18.4 x 20.8
L4 2.2L Turbo I	84-89	EJ-D23A							9 3/16" - 233mm	18D - 18.4 x 20.8
L4 2.2L SOHC	90	EJ-D21E							8 1/2" - 216mm	18D - 18.1x21.3
L4 2.2L Turbo	90	EJ-D23O							9" - 229mm	18D - 18.4 x 20.8
L4 2.2L	91-94	EJ-D21F							8 1/2" - 216mm	17D - 20.2x23.2
<b>Aspen</b>										
L4 2.6L	77-83	EJ-D23W							8 7/8" - 225mm	23D - 23.2 x 26.2
<b>Atos</b>										
L4 1.0L 12V 5 Vel.	01-04	EJ-D18B							7 1/16" - 180mm	24D - 18.3 x 20.0
L4 1.1L 12V 5 Vel.	05-08	EJ-D18B							7 1/16" - 180mm	24D - 18.3 x 20.0
<b>Attitude</b>										
L4 1.4L 104HP, 5 Vel.	04-11	EJ-D22F							8 1/2" - 216mm	20D - 19.7x22.3
<b>Avenger</b>										
L4 2.0L	95-98	EJ-D22C	X						8 11/16" - 220mm	17D
<b>Breeze</b>										
L4 2.0L 150HP, DOHC, Transm. A578	96	EJ-D22C	X						8 11/16" - 220mm	17D
L4 2.0L MPFI, DOHC, 5Vel. Transm. NV-T350	96-98	EJ-D23D							9" - 229mm	17D - 20.3 x 23.8
<b>Charger</b>										
L4 2.2L	81-88	EJ-D22A							8 1/2" - 216mm	18D - 18.4 x 20.8
L4 2.2L Turbo I	81-89	EJ-D22A							8 1/2" - 216mm	18D - 18.4 x 20.8
L4 2.2L Turbo I	84-87	EJ-D23A							9 3/16" - 233mm	18D - 18.4 x 20.8
<b>Cirrus</b>										
L4 2.0L	00	EJ-D22C	X						8 11/16" - 220mm	17D
<b>Dart K</b>										
L4 2.2L 4 Vel.	82-88	EJ-D22A							8 1/2" - 216mm	18D - 18.4 x 20.8
<b>Dart E</b>										
L4 2.5L 5 Vel.	87-89	EJ-D23A							9 3/16" - 233mm	18D - 18.4 x 20.8
<b>Daytona</b>										
L4 2.2L	81-89	EJ-D22A							8 1/2" - 216mm	18D - 18.4 x 20.8
L4 2.2L Turbo I	84-89	EJ-D23A							9 3/16" - 233mm	18D - 18.4 x 20.8
L4 2.2L SOHC	90	EJ-D21E							8 1/2" - 216mm	18D - 18.1x21.3
L4 2.2L Turbo	90	EJ-D23O							9" - 229mm	18D - 18.4 x 20.8
L4 2.2L	91-94	EJ-D21F							8 1/2" - 216mm	17D - 20.2x23.2
L4 2.5L c/y s/Turbo	86-89	EJ-D23A							9 3/16" - 233mm	18D - 18.4 x 20.8



**BOMBA DE AGUA**  
**FAN CLUTCH**

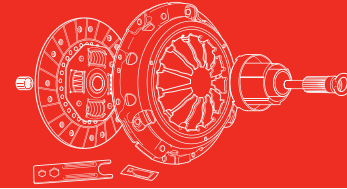

APLICACIÓN



NÚMERO DE PARTE

MODULAR

AUTO-AJUSTABLE

VOLANTE

BI-MASA

COLL. HID. INCLUIDO

NÚMERO DE IMAGEN COLL. HID.

PÁGINA DE IMAGEN COLL. HID.

DIÁMETRO

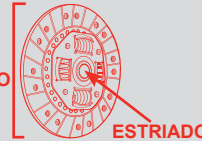

ESTRIADO

### CHRYSLER / DODGE - AUTOMÓVIL

Continuación

#### Horizon

L4 2.2 Turbo	81-88	EJ-D23A							9 3/16" - 233mm	18D - 18.4 x 20.8
--------------	-------	---------	--	--	--	--	--	--	-----------------	-------------------

#### Lancer

L4 2.2L	81-89	EJ-D22A							8 1/2" - 216mm	18D - 18.4 x 20.8
L4 2.2L Turbo I	84-89	EJ-D23A							9 3/16" - 233mm	18D - 18.4 x 20.8
L4 2.2L Turbo	90	EJ-D23O							9" - 229mm	18D - 18.4 x 20.8
L4 2.2L	91-94	EJ-D21F							8 1/2" - 216mm	17D - 20.2x23.2
L4 2.5L c/y s/Turbo	86-89	EJ-D23A							9 3/16" - 233mm	18D - 18.4 x 20.8

#### Laser

L4 2.2L	84-86	EJ-D22A							8 1/2" - 216mm	18D - 18.4 x 20.8
L4 2.2L Turbo	81-88	EJ-D23A							9 3/16" - 233mm	18D - 18.4 x 20.8

#### Lebaron

L4 2.2L	82-89	EJ-D22A							8 1/2" - 216mm	18D - 18.4 x 20.8
L4 2.2L	82-89	EJ-D23A							9 3/16" - 233mm	18D - 18.4 x 20.8
L4 2.5L c/y s/Turbo	86-89	EJ-D23A							9 3/16" - 233mm	18D - 18.4 x 20.8

#### Magnum K

L4 2.2L Turbo I, 5 Vel.	84-87	EJ-D23A							9 3/16" - 233mm	18D - 18.4 x 20.8
L4 2.2L Turbo II, 5 Vel.	85-87	EJ-D23A							9 3/16" - 233mm	18D - 18.4 x 20.8

#### Neon

L4 2.0L MPFI, SOHC, 5 Vel., Transm. A-578, 11o. Dígito VIN "T"	94-98	EJ-D23D							9" - 229mm	17D - 20.3 x 23.8
L4 2.0L MPFI, DOHC, 5 Vel., Transm. A-578	96-98	EJ-D22C	X						8 11/16" - 220mm	17D
L4 2.0L MPFI, 5 Vel., Transm. A-578	98-05	EJ-D22C	X						8 11/16" - 220mm	17D

#### Neon SRT-4

L4 2.4L 230HP, 16V 5 Vel.	04-05	EJ-D24A	X	X					9 1/2" - 241mm	17D
---------------------------	-------	---------	---	---	--	--	--	--	----------------	-----

#### Neon R/T

L4 2.0L 16V, 5 Vel,	99	EJ-D22C	X						8 11/16" - 220mm	17D
---------------------	----	---------	---	--	--	--	--	--	------------------	-----

#### Omni

L4 2.2L Turbo I	84-87	EJ-D23A							9 3/16" - 233mm	18D - 18.4 x 20.8
-----------------	-------	---------	--	--	--	--	--	--	-----------------	-------------------

#### Phantom

L4 2.2L 140HP, Turbo II, 5 Vel.	84-90	EJ-D23A							9 3/16" - 233mm	18D - 18.4 x 20.8
---------------------------------	-------	---------	--	--	--	--	--	--	-----------------	-------------------

#### Phantom R/T

L4 2.5L 160HP, Turbo II, 5 Vel.	89-91	EJ-D23A							9 3/16" - 233mm	18D - 18.4 x 20.8
---------------------------------	-------	---------	--	--	--	--	--	--	-----------------	-------------------

#### PT Cruiser

L4 2.4L 150HP, DOHC, 16V, 5 Vel.	00-05	EJ-D23P	X	X					9 1/16" - 230mm	17D
----------------------------------	-------	---------	---	---	--	--	--	--	-----------------	-----

#### Reliant

L4 2.2 Turbo	81-88	EJ-D23A							9 3/16" - 233mm	18D - 18.4 x 20.8
L4 2.5 Turbo	81-88	EJ-D23A							9 3/16" - 233mm	18D - 18.4 x 20.8

#### Shadow

L4 2.2L 97HP, 5 Vel.	88-89	EJ-D22A							8 1/2" - 216mm	18D - 18.4 x 20.8
L4 2.2L	91-94	EJ-D21F							8 1/2" - 216mm	17D - 20.2x23.2
L4 2.2L	90	EJ-D21E							8 1/2" - 216mm	18D - 18.1x21.3
L4 2.2L Turbo I	90	EJ-D23O							9" - 229mm	18D - 18.4 x 20.8
L4 2.5L 101HP, 5 Vel.	87-89	EJ-D23A							9 3/16" - 233mm	18D - 18.4 x 20.8



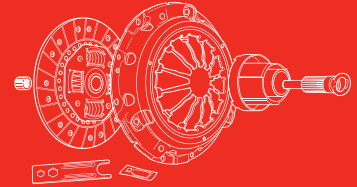

APLICACIÓN	01	NÚMERO DE PARTE	MODULAR	AUTO-AJUSTABLE	VOLANTE BI-MASA	COLL. HID. INCLUIDO	NÚMERO DE IMAGEN COLL. HID.	PÁGINA DE IMAGEN COLL. HID.	DIÁMETRO	ESTRIADO
<b>CHRYSLER / DODGE - AUTOMÓVIL</b>										
<b>Shadow</b>										Continuación
<b>Shadow GTS</b>										Continuación
L4 2.5L 97HP, MPFI, 5 Vel., Transm. New Process Gear A-523	87-89	EJ-D23N							9" - 228mm	17D - 20.3 x 23.8
L4 2.5L 152HP, MPFI, Turbo II, 5 Vel.	89-91	EJ-D23A							9 3/16" - 233mm	18D - 18.4 x 20.8
<b>Spirit</b>										
L4 2.2L	90	EJ-D21E							8 1/2" - 216mm	18D - 18.1x21.3
L4 2.2L	91-94	EJ-D21F							8 1/2" - 216mm	17D - 20.2x23.2
L4 2.2L Turbo	90	EJ-D23O							9" - 229mm	18D - 18.4 x 20.8
L4 2.5L 152HP, Turbo II, 5 Vel.	89-91	EJ-D23A							9 3/16" - 233mm	18D - 18.4 x 20.8
<b>Spirit R/T</b>										
L4 2.5L 160HP, MPFI, 5 Vel.	90-94	EJ-D23O							9" - 229mm	18D - 18.4 x 20.8
<b>Stealth</b>										
L4 2.0L.	95-00	EJ-D22C	X						8 11/16" - 220mm	17D
<b>Stratus</b>										
L4 2.0L 132HP, MPFI, SOHC, 5 Vel., Transm. New Venture Gear NV-T350	95-00	EJ-D23D							9" - 229mm	17D - 20.3 x 23.8
L4 2.0L MPFI, DOHC, 16V, 5 Vel.	95-06	EJ-D22C	X						8 11/16" - 220mm	17D
L4 2.4L	97-00	EJ-D22C	X						8 11/16" - 220mm	17D
<b>Sundance</b>										
L4 2.2L	91-94	EJ-D21F							8 1/2" - 216mm	17D - 20.2x23.2
<b>Verna</b>										
L4 1.5L 90HP, OHC, 5 Vel.	04-05	EJ-D20C							7 7/8" - 200mm	20D - 19.8 x 22.5
L4 1.6L 104HP, 5 Vel.	04-05	EJ-D22F							8 1/2" - 216mm	20D - 19.7x22.3
<b>Viper</b>										
V10 8.3L (505") 500HP, 6 Vel., Transm. T-56	03-06	EJ-D31A							12 3/8" - 313mm	26D - 26.6 x 29.6
V10 8.3L (505") 500HP, 6 Vel., Transm. T-56	03-06	EJ-D31A3				X	EC-F23P3	48	12 3/8" - 313mm	26D - 26.6 x 29.6
<b>Volare K</b>										
L4 2.2L 4 Vel.	82-88	EJ-D22A							8 1/2" - 216mm	18D - 18.4 x 20.8
L4 2.5L 5 Vel.	87-89	EJ-D23A							9 3/16" - 233mm	18D - 18.4 x 20.8
<b>CHRYSLER/DODGE-PICK-UP/CAMIONETA</b>										
<b>Caravan</b>										
L4 2.2L SOHC	83-88	EJ-D23B							9 3/16" - 233mm	18D - 18.5 x 20.3
L4 2.5L	83-89	EJ-D23A							9 3/16" - 233mm	18D - 18.4 x 20.8
L4 2.5L	90	EJ-D23O							9" - 229mm	18D - 18.4 x 20.8
L4 2.5L	91-92	EJ-D23F							9" - 228mm	17D - 20.3 x 23.8
L4 2.5L	93-95	EJ-D23H	X						9 3/16" - 233mm	17D
L4 3.0L	93-95	EJ-D23H	X						9 3/16" - 233mm	17D
L4 3.3L	93-95	EJ-D23H	X						9 3/16" - 233mm	17D
<b>D50</b>										
L4 2.0L	81-90	EJ-D22G							8 1/2" - 216mm	23D - 23.0 x 26.0
<b>D100</b>										
L6 3.7L (225")	69-83	EJ-D28L							11" - 280mm	23D - 24 x 26
V6 3.9L (238") 4 Vel.	88-91	EJ-D28B							11" - 280mm	23D - 23.7 x 25.9

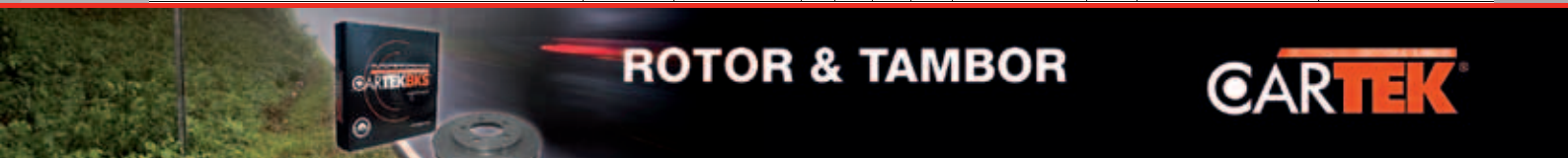

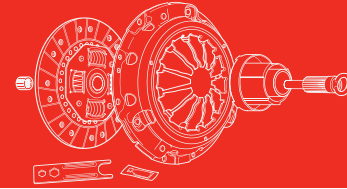

APLICACIÓN



NÚMERO DE PARTE

MODULAR

AUTO-AJUSTABLE

VOLANTE

BIMASA

COLL. HID. INCLUIDO

NÚMERO DE IMAGEN COLL. HID.

PÁGINA DE IMAGEN COLL. HID.

DIÁMETRO

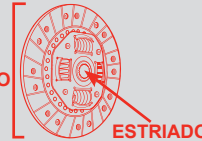

ESTRIADO

### CHRYSLER / DODGE - PICK-UP / CAMIONETA

Continuación

D100										Continuación	
V8 5.2L (318")	81-85	EJ-D28L								11" - 280mm	23D - 24 x 26
V8 5.2L (318")	88-91	EJ-D28B								11" - 280mm	23D - 23.7 x 25.9
V8 5.2L (318")	94-00	EJ-D30A								11 13/16" - 300mm	10D - 1 1/8"
V8 5.9L (360")	71-87	EJ-D28L								11" - 280mm	23D - 24 x 26
V8 5.9L (360")	88-91	EJ-D28B								11" - 280mm	23D - 23.7 x 25.9
V8 5.9L (360")	94-02	EJ-D30A								11 13/16" - 300mm	10D - 1 1/8"
D150											
V6 3.7L (225") 106HP, 4 Vel., Transm. Tremec 190-FT	70-87	EJ-D28A								11" - 280mm	10D - 1 3/8"
D150 Adventurer, Club Cab											
V6 3.9L (238") 4 Vel.	88-91	EJ-D28P								11" - 280mm	23D - 23.7 x 25.9
L6 3.9L (238") 180HP, 4Vel., Tremec 199-F9, 177-FT23	69-83	EJ-D28F								11" - 280mm	19D - 22.6 x 25.9
D250											
L6 3.7L (225")	69-83	EJ-D28L								11" - 280mm	23D - 24 x 26
V6 3.9L (238") 4 Vel.	88-91	EJ-D28B								11" - 280mm	23D - 23.7 x 25.9
V8 5.2L (318")	81-85	EJ-D28L								11" - 280mm	23D - 24 x 26
V8 5.2L (318")	88-91	EJ-D28B								11" - 280mm	23D - 23.7 x 25.9
V8 5.2L (318")	94-00	EJ-D30A								11 13/16" - 300mm	10D - 1 1/8"
D250 Ram Charger											
V8 5.9L (360") 245HP, 4 Vel., Transm. Tremec 177-FT16	88-90	EJ-D28B								11" - 280mm	23D - 23.7 x 25.9
V8 5.9L (360") 245HP, 4 Vel., Transm. Tremec 199-F2	91	EJ-D28B								11" - 280mm	23D - 23.7 x 25.9
D250 Adventurer											
V8 5.9L (360") 245HP, 4 Vel., Transm. Tremec 199-F9	92	EJ-D28F								11" - 280mm	19D - 22.6 x 25.9
V8 5.9L (360") 245HP, 4 Vel., Transm. Tremec Clark 177-FT, Tremec 199-F9, Tremec 177-FT23	92-93	EJ-D28F								11" - 280mm	19D - 22.6 x 25.9
D250 Power Ram											
V8 5.9L (360") 245HP, 4 Vel., Transm. Tremec 177-FT16, Tremec 199-F2	88-91	EJ-D28B								11" - 280mm	23D - 23.7 x 25.9
D250 Prospector											
V8 5.9L (360") 245HP, 4 Vel., Transm. Tremec 177-FT16, Tremec 199-F2	88-91	EJ-D28B								11" - 280mm	23D - 23.7 x 25.9
D350											
V8 5.9L (360") 245HP, 4 Vel., Transm. Tremec 190-FT	70-87	EJ-D28A								11" - 280mm	10D - 1 3/8"
V8 5.9L (360") 245HP, 4 Vel., Transm. New Process Gear 435	70-87	EJ-D28D								11 1/16" - 281mm	23D - 23.1 x 26.1
V8 5.9L (360") 245HP, 4 Vel., Transm. Tremec 190-F39, Clark T90-F17, Tremec 190-F22	88-91	EJ-D28B								11" - 280mm	23D - 23.7 x 25.9
V8 5.9L (360") 245HP, 4 Vel., Transm. Tremec 190-F39, Clark T90-F17, Tremec 190-F22	88-91	EJ-D30C								11 13/16" - 300mm	23D - 23.7 x 25.9
V8 5.9L (360") 245HP, 4 Vel., Transm. Tremec 199-F4, Clark T90-F17	92-93	EJ-D28F								11" - 280mm	19D - 22.6 x 25.9



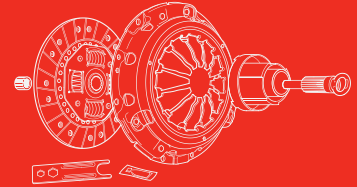

APLICACIÓN	01	NÚMERO DE PARTE	MODULAR	AUTO-AJUSTABLE	VOLANTE	BI-MASA	COLL. HID. INCLUIDO	NÚMERO DE IMAGEN COLL. HID.	PÁGINA DE IMAGEN COLL. HID.	DIÁMETRO	ESTRIADO
------------	----	-----------------	---------	----------------	---------	---------	---------------------	-----------------------------	-----------------------------	----------	----------

**CHRYSLER / DODGE - PICK-UP / CAMIONETA** Continuación

<b>Dakota</b>											
L4 2.5L 120HP, 5 Vel.	88-91	EJ-D23R								9 1/8" - 232mm	23D - 25.88 x 23.76
L4 2.5L 120HP, 5 Vel.	92	EJ-D23U								9 3/16" - 233mm	19D - 25.75 x 22.76
L4 2.5L 120HP, 5 Vel.	96	EJ-D23X								9 1/8" - 232mm	14D - 21.5 x 25.1
L4 2.5L 120HP, 5 Vel., Transm. New Process Gear 535	96-97	EJ-D23K								9 1/8" - 232mm	10D - 1 1/8"
V6 3.7L (225") 210HP, 6 Vel.	04	EJ-D30H								11 7/8" - 302mm	10D - 23.2 x 28.8
V6 3.9L (238")	87-91	EJ-D26F								10 3/8" - 263mm	23D - 24 x 26
V6 3.9L (238")	92-99	EJ-D27J								10 7/16" - 265mm	10D - 1 1/8"
V6 3.9L (238") 6 Vel.	01-03	EJ-D30H								11 7/8" - 302mm	10D - 23.2 x 28.8
<b>Dakota Gas</b>											
V8 4.7L (280") 6 Vel., Transm. DEJ	02-05	EJ-D30H								11 7/8" - 302mm	10D - 23.2 x 28.8
<b>H-100</b>											
L4 2.4L SOHC, 5 Vel.	03-05	EJ-D24D								9 7/16" - 240mm	23D - 23.1 x 26.1
L4 2.5L Diesel, 5 Vel.	06-10	EJ-D24E								9 7/16" - 240mm	23D - 23.1 x 26.1
<b>Mini Ram Van</b>											
L4 2.2L	86-89	EJ-D23B								9 3/16" - 233mm	18D - 18.5 x 20.3
L4 2.2L	93-95	EJ-D23H	X							9 3/16" - 233mm	17D
L4 2.2L	91-92	EJ-D23F								9" - 228mm	17D - 20.3 x 23.8
L4 2.5L	98-01	EJ-D23G	X							9 1/16" - 230mm	17D
L4 2.5L	93-95	EJ-D23H	X							9 3/16" - 233mm	17D
L4 2.6 L (158")	84-87	EJ-D23W								8 7/8" - 225mm	23D - 23.2 x 26.2
V6 3.0L	93-95	EJ-D23H	X							9 3/16" - 233mm	17D
V6 3.3L	93-94	EJ-D23H	X							9 3/16" - 233mm	17D
<b>Power Ram 50</b>											
L4 2.0L	81-90	EJ-D22G								8 1/2" - 216mm	23D - 23.0 x 26.0
L4 2.4L	90-93	EJ-D23W								8 7/8" - 225mm	23D - 23.2 x 26.2
L4 2.6L (158")	84-89	EJ-D23W								8 7/8" - 225mm	23D - 23.2 x 26.2
<b>Plymouth Voyager</b>											
L4 2.5L	90	EJ-D23O								9" - 229mm	18D - 18.4 x 20.8
L4 2.5L	91-92	EJ-D23F								9" - 228mm	17D - 20.3 x 23.8
<b>Ram 50</b>											
L4 2.0L	81-90	EJ-D22G								8 1/2" - 216mm	23D - 23.0 x 26.0
L4 2.4L	90-93	EJ-D23W								8 7/8" - 225mm	23D - 23.2 x 26.2
L4 2.6L (158")	84-89	EJ-D23W								8 7/8" - 225mm	23D - 23.2 x 26.2
<b>Ram 1500</b>											
L6 3.7L (225") C/portacollarín	65-87	EJ-D28A								11" - 280mm	10D - 1 3/8"
L6 3.7L (225")	69-83	EJ-D28L								11" - 280mm	23D - 24 x 26
L6 3.7L (225") 4 Vel.	70-87	EJ-D28D								11 1/16" - 281mm	23D - 23.1 x 26.1
V6 3.7L (225")	04-09	EJ-D30F				X				11 7/8" - 302mm	10D - 1 1/8"
V6 3.9L (238") 4 Vel.	88-91	EJ-D28B								11" - 280mm	23D - 23.7 x 25.9
V6 3.9L (238") 180HP, MPFI, 4 Vel., Transm. Tremec 199-A14	94-00	EJ-D28H								11" - 280mm	10D - 1 1/8"



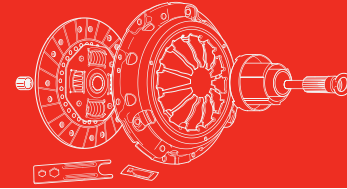

APLICACIÓN

01

NÚMERO DE PARTE

MODULAR

AUTO-AJUSTABLE

VOLANTE

BIMASA

COLL. HID. INCLUIDO

NÚMERO DE IMAGEN COLL. HID.

PÁGINA DE IMAGEN COLL. HID.

DIÁMETRO

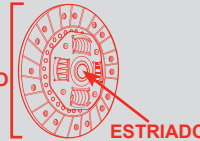

ESTRIADO

### CHRYSLER / DODGE - PICK-UP / CAMIONETA

Continuación

#### Ram 1500

Continuación

V6 3.9L (238") 5 Vel.,	01-04	EJ-D30I						11 7/8" - 302mm	10D - 1 1/8"
V6 3.9L (238") 5 Vel.,	01-04	EJ-D30F				X		11 7/8" - 302mm	10D - 1 1/8"
V8 4.7L (286") 235HP, 5 Vel., 4x2, 4x4	02-07	EJ-D30E				X		11 7/8" - 302mm	10D - 1 1/8"
V8 5.2L (318")	81-85	EJ-D28L						11" - 280mm	23D - 24 x 26
V8 5.2L (318")	88-91	EJ-D28B						11" - 280mm	23D - 23.7 x 25.9
V8 5.2L (318") MPFI, 4 Vel., Tremec TR-3340-4	94-00	EJ-D30A						11 13/16" - 300mm	10D - 1 1/8"
V8 5.2L (318") 230HP, 4X2, 4X4	01	EJ-D30E				X		11 7/8" - 302mm	10D - 1 1/8"

#### RAM 1500, Pick-Up 4x2

V6 3.9L (238")	01-04	EJ-D30F				X		11 7/8" - 302mm	10D - 1 1/8"
V6 3.9L (238") 5 Vel.	01-04	EJ-D30I						11 7/8" - 302mm	10D - 1 1/8"

#### RAM 1500, Pick-Up 4x4

V8 5.2L (316") 4 Vel.	94-00	EJ-D30A						11 13/16" - 300mm	10D - 1 1/8"
-----------------------	-------	---------	--	--	--	--	--	-------------------	--------------

#### RAM 2500

V8 4.7L (286") 235HP, 5 Vel., 4x2, 4x4	02-07	EJ-D30E				X		11 7/8" - 302mm	10D - 1 1/8"
V8 5.2L (318")	81-85	EJ-D28L						11" - 280mm	23D - 24 x 26
V8 5.2L (318")	88-91	EJ-D28B						11" - 280mm	23D - 23.7 x 25.9
V8 5.2L (318")	94-00	EJ-D30A						11 13/16" - 300mm	10D - 1 1/8"
V8 5.2L (318") 230HP, 4X2, 4X4	01	EJ-D30E				X		11 7/8" - 302mm	10D - 1 1/8"
V8 5.7L (350") 230HP, 5 Vel., Transm. NVG 4500	03-05	EJ-D29A						11 7/16" - 290mm	10D - 1 1/8"
V8 5.9L (360") TBI, Transm, Tremec 199-A14, 199-A24, TR 3340-4, TR 3340-9	94-00	EJ-D30A						11 13/16" - 300mm	10D - 1 1/8"
V8 5.9L (360") MPFI, 5 Vel.	00-02	EJ-D30A						11 13/16" - 300mm	10D - 1 1/8"

#### RAM 2500, Pick-Up 4x2

V8 5.2L (318") 5 Vel.	01-03	EJ-D30E				X		11 7/8" - 302mm	10D - 1 1/8"
V8 5.9L (360") 4 Vel.	94-00	EJ-D30A						11 13/16" - 300mm	10D - 1 1/8"

#### RAM 2500, Pick-Up 4x4

V8 5.2L (318") 5 Vel.	01-03	EJ-D30E				X		11 7/8" - 302mm	10D - 1 1/8"
V8 5.9L (360") 4 Vel.	94-00	EJ-D30A						11 13/16" - 300mm	10D - 1 1/8"

#### RAM 3500

V8 4.7L (286") 235HP, 5 Vel., 4x2, 4x4	02-07	EJ-D30E				X		11 7/8" - 302mm	10D - 1 1/8"
V8 5.2L (318")	81-85	EJ-D28L						11" - 280mm	23D - 24 x 26
V8 5.2L (318")	88-91	EJ-D28B						11" - 280mm	23D - 23.7 x 25.9
V8 5.2L (318")	94-00	EJ-D30A						11 13/16" - 300mm	10D - 1 1/8"
V8 5.2L (318") 230HP, 4X2, 4X4	01	EJ-D30E				X		11 7/8" - 302mm	10D - 1 1/8"
V8 5.9L (360")	71-87	EJ-D28L						11" - 280mm	23D - 24 x 26
V8 5.9L (360")	88-91	EJ-D28B						11" - 280mm	23D - 23.7 x 25.9
V8 5.9L (360") MPFI, Transm, Tremec T199-A14	96-02	EJ-D30A						11 13/16" - 300mm	10D - 1 1/8"
L6 5.9L (360") Turbo Diesel, Transm G56 6 Vel. Versión NO Autoajustable, Versión Volante Sólido (Incluye Volante Sólido)	05->>	EJ-D33G						13 1/8" - 333mm	10D - 1 3/8"
L6 6.7L (408") Turbo Diesel, Transm G56 6 Vel. Versión NO Autoajustable, Versión Volante Sólido (Incluye Volante Sólido)	05->>	EJ-D33G						13 1/8" - 333mm	10D - 1 3/8"

#### RAM 3500, Pick-Up 4x2

V8 5.7L (350") 5 Vel.	03->>	EJ-D29A						11 7/16" - 290mm	10D - 1 1/8"
-----------------------	-------	---------	--	--	--	--	--	------------------	--------------



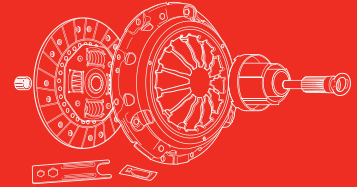

APLICACIÓN	01	NÚMERO DE PARTE	MODULAR	AUTO-AJUSTABLE	VOLANTE BI-MASA	COLL. HID. INCLUIDO	NÚMERO DE IMAGEN COLL. HID.	PÁGINA DE IMAGEN COLL. HID.	DIÁMETRO	ESTRIADO
<b>CHRYSLER / DODGE - PICK-UP / CAMIONETA</b>										
<b>RAM 3500, Pick-Up 4x2</b>										
V8 5.9L (360")	94-00	EJ-D30A							11 13/16" - 300mm	10D - 1 1/8"
V8 5.9L (360")	00-02	EJ-D30A							11 13/16" - 300mm	10D - 1 1/8"
<b>RAM 4000</b>										
V8 5.7L (350") MPFI, 5Vel, Transm, NVG 4500	03-07	EJ-D29A							11 7/16" - 290mm	10D - 1 1/8"
V8 5.9L (360") MPFI,	96-00	EJ-D30A							11 13/16" - 300mm	10D - 1 1/8"
V8 5.9L (360")	00-02	EJ-D30A							11 13/16" - 300mm	10D - 1 1/8"
V10 8.0L (488")	05	EJ-D31A							12 3/8" - 313mm	26D - 26.6 x 29.6
<b>RAM Club Cab</b>										
V8 5.9L (360")	95-98	EJ-D30A							11 13/16" - 300mm	10D - 1 1/8"
<b>RAM 4000 Runner</b>										
V10 8.0 L (488")	95-97	EJ-D31C							12 5/16" - 312mm	10D - 1 1/2"
<b>CHRYSLER / DODGE - MICROBÚS</b>										
<b>Microbús</b>										
V8 5.9L (360") 4 Vel.	88-91	EJ-D30C							11 13/16" - 300mm	23D - 23.7 x 25.9
V8 5.9L (360") c/portacollarín	92-93	EJ-D33C							13 1/8" - 333mm	10D - 1 3/8"
V8 5.9L (360") c/portacollarín	94-98	EJ-D33D							13 1/16" - 332mm	10D - 1 3/8"
<b>Microbús DM 350</b>										
V8 5.9L (360") Carb, TBI, Transm. Tremec, T-199, T-177	92	EJ-D28F							11" - 280mm	19D - 22.6 x 25.9
<b>FIAT - AUTOMÓVIL</b>										
<b>Palio sedán</b>										
L4 1.6L 103HP, MPFI, DOHC	04-09	EJ-FI20A							7 7/8" - 200mm	20D -
<b>Palio Adventurer</b>										
L4 1.6L 103HP, MPFI, DOHC	04-09	EJ-FI20A							7 7/8" - 200mm	20D -
<b>FORD - AUTOMÓVIL</b>										
<b>Contour</b>										
L4 2.0L 125HP, DOHC, 16V, 5 Vel., Transm. MTX75	96-99	EJ-F24C				X	EC-F23J	47	9 7/16" - 240mm	23D - 23.1 x 26.1
V6 2.5L 170HP, DOHC, 24V, 5 Vel., Transm MTX 75	98-00	EJ-F24B				X	EC-F24B	48	9 1/2" - 241mm	23D - 23.1 x 26.1
<b>Contour SVT</b>										
V6 2.5L 195HP, DOHC, 24V, 5 Vel., Transm MTX 75	98-00	EJ-F24B				X	EC-F24B	48	9 1/2" - 241mm	23D - 23.1 x 26.1
<b>Escort</b>										
L4 1.6L	81-82	EJ-F20A							7 7/8" - 200mm	20D - 19.9x22.5
L4 1.8L 127HP, DOHC	94-95	EJ-F23H							8 7/8" - 225mm	22D - 22.3 x 24.3
L4 1.8L 98HP, SOHC	95-96	EJ-F20B							7 7/8" - 200mm	20D - 20.2 x 22.2
L4 1.9L	85-87	EJ-F22A							8 1/2" - 216mm	20D - 20.1 x 23.1
L4 1.9L	88-90	EJ-F22B							8 1/2" - 216mm	20D - 20.1 x 23.1
L4 2.0L 110HP, SOHC, 5 Vel.	97-01	EJ-F23C							8 7/8" - 225mm	22D - 22.3 x 24.3
<b>Escort EXP</b>										
L4 1.6L	81-82	EJ-F20A							7 7/8" - 200mm	20D - 19.9x22.5
L4 1.9L	85-87	EJ-F22A							8 1/2" - 216mm	20D - 20.1 x 23.1
L4 1.9L	88-90	EJ-F22B							8 1/2" - 216mm	20D - 20.1 x 23.1

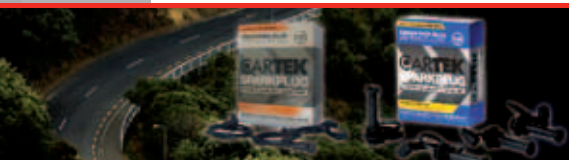

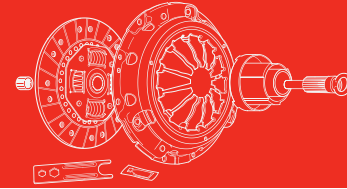

APLICACIÓN

01

NÚMERO DE PARTE

MODULAR

AUTO-AJUSTABLE

VOLANTE

BIMASA

COLL. HID. INCLUIDO

NÚMERO DE IMAGEN COLL. HID.

PÁGINA DE IMAGEN COLL. HID.

DIÁMETRO

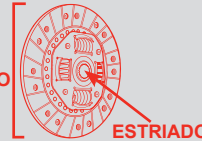

Continuación

### FORD - AUTOMÓVIL

#### Escort ZX2

L4 1.9L	85-87	EJ-F22A							8 1/2" - 216mm	20D - 20.1 x 23.1
L4 1.9L	88-90	EJ-F22B							8 1/2" - 216mm	20D - 20.1 x 23.1
L4 2.0L 130HP, DOHC, 16V, 5 Vel.	98-01	EJ-F23C							8 7/8" - 225mm	22D - 22.3 x 24.3

#### Fairmont

V8 5.0L (302") 3 y 4 Vel.	78-81	EJ-F28A4							11 1/16" - 281mm	10D - 1 1/16"
---------------------------	-------	----------	--	--	--	--	--	--	------------------	---------------

#### Fiesta

L4 1.3L 60HP, OHV, Zetec, 5 Vel.	98-00	EJ-F18B							7 1/16" - 180mm	17D - 17.0 x 20.0
L4 1.3L 60HP, OHV, Zetec, 5 Vel.	01-02	EJ-F18C				X	EC-F19A	47	7 1/16" - 180mm	17D - 17.0 x 20.0
L4 1.4L 90HP, DOHC, Zetec, 5 Vel.	98-00	EJ-F18B							7 1/16" - 180mm	17D - 17.0 x 20.0
L4 1.4L 90HP, DOHC, Zetec, 5 Vel.	01-02	EJ-F18C				X	EC-F19A	47	7 1/16" - 180mm	17D - 17.0 x 20.0
L4 1.6L 90HP, 8V, SOHC, 5 Vel.	01-07	EJ-F19B				X			7 1/2" - 190mm	17D - 17.0 x 20.0

#### Focus

L4 2.0L 110HP, OHV, 5 Vel., Transm IB5	00	EJ-F22H				X	EC-F19A	47	8 11/16" - 220mm	17D - 17.0 x 20.0
L4 2.0L 145HP, DOHC, 5 Vel., Transm MTX75	99-04	EJ-F23I				X	EC-F23I	47	9" - 228mm	23D - 23.1 x 25.9

#### Focus ZX3

L4 2.0L 130HP, DOHC, Zetec, 5 Vel., Transm MTX5	00-05	EJ-F23I				X	EC-F23I	47	9" - 228mm	23D - 23.1 x 25.9
---	-------	---------	--	--	--	---	---------	----	------------	-------------------

#### Focus SVT

L4 2.0L 170HP, DOHC, 6 Vel., Transm MTX75	02-05	EJ-F24E			X	X			9 7/16" - 240mm	14D
---	-------	---------	--	--	---	---	--	--	-----------------	-----

#### Granada

L6 4.1L (252")	1975-80	EJ-F25F							10" - 254mm	10D - 1 1/16"
V8 5.0L (302")	80	EJ-F28A4							11 1/16" - 281mm	10D - 1 1/16"

#### Ikon

L4 1.6L 90HP, 8V, 5 Vel.	01-06	EJ-F19A				X	EC-F19A	47	7 1/2" - 190mm	17D - 17.0 x 20.0
--------------------------	-------	---------	--	--	--	---	---------	----	----------------	-------------------

#### Ka

L4 1.6L Zetec, 8V, 5 Vel.	01-08	EJ-F19A				X	EC-F19A	47	7 1/2" - 190mm	17D - 17.0 x 20.0
---------------------------	-------	---------	--	--	--	---	---------	----	----------------	-------------------

#### LTD II

L6 4.1L (252")	1975-80	EJ-F25F							10" - 254mm	10D - 1 1/16"
V6 4.2L (302")	80	EJ-F25F							10" - 254mm	10D - 1 1/16"

#### Mondeo Core MTX

L4 2.0L 145HP, DOHC, 5 Vel.	01-03	EJ-F23J				X	EC-F23J	47	9" - 228mm	23D - 23.1 x 26.1
-----------------------------	-------	---------	--	--	--	---	---------	----	------------	-------------------

#### Mondeo Trend MTX

V6 2.5L 170HP, DOHC, 6 Vel.	01-04	EJ-F24D				X	EC-F24B	48	9.4375 - 240mm	23D - 23.1 x 26.1
-----------------------------	-------	---------	--	--	--	---	---------	----	----------------	-------------------

#### Mustang

L4 2.3L 4 Vel.	74-83	EJ-F21C							8 1/2" - 216mm	10D - 1 1/2"
L4 2.3L 5 Vel.	87-94	EJ-F21C							8 1/2" - 216mm	10D - 1 1/2"
L4 2.3L Turbo, 4 Vel.	79-82	EJ-F21D							8 7/16" - 214mm	10D -
L4 2.3L 5 Vel.	80-83	EJ-F22I							8 7/16" - 215mm	23D -
V8 5.0L (302") 3 y 4 Vel.	65-85	EJ-F28A4							11 1/16" - 281mm	10D - 1 1/16"
V8 5.0L (302")	79-85	EJ-F25G							10" - 254mm	10D - 1 1/16"
V8 5.7L (350") 3 y 4 Vel.	65-84	EJ-F28A4							11 1/16" - 281mm	10D - 1 1/16"

#### Mustang GT

V8 4.6L (280") EFI, 5 Vel., Transm T45	94-01	EJ-F27A							10 1/2" - 267mm	10D - 1 1/16"
--	-------	---------	--	--	--	--	--	--	-----------------	---------------



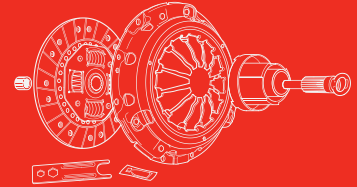

APLICACIÓN	01	NÚMERO DE PARTE	MODULAR	AUTO-AJUSTABLE	VOLANTE BI-MASA	COLL. HID. INCLUIDO	NÚMERO DE IMAGEN COLL. HID.	PÁGINA DE IMAGEN COLL. HID.	DIÁMETRO	ESTRIADO
<b>FORD - AUTOMÓVIL</b>										
<b>Mustang GT</b>										
V8 4.6L (280") EFI, 5 Vel., Transm TR3650	01-04	EJ-F28L							11" - 280mm	10D - 1 1/16"
<b>Mystique</b>										
L4 2.0L 125HP, 5 Vel.	95-98	EJ-F24C				X	EC-F23J	47	9 7/16" - 240mm	23D - 23.1 x 26.1
V6 2.5L Duratec, 5 Vel.	95-00	EJ-F24B				X	EC-F24B	48	9 1/2" - 241mm	23D - 23.1 x 26.1
<b>Probe</b>										
V6 2.5L	93-97	EJ-F23F							8 7/8" - 225mm	22D - 22.3 x 24.3
<b>Taurus</b>										
L4 2.5L HSC	86-89	EJ-F22A							8 1/2" - 216mm	20D - 20.1 x 23.1
<b>Tempo</b>										
L4 2.3L 4 Vel.	84-88	EJ-F22A							8 1/2" - 216mm	20D - 20.1 x 23.1
L4 2.3L 5 Vel. (Sin Casquillo candelero)	88-94	EJ-F22B							8 1/2" - 216mm	20D - 20.1 x 23.1
<b>Thunderbird Deseo</b>										
V6 3.8L (231") 5 Vel. (Con balero p/CSC)	90-92	EJ-F29B							11 9/16" - 293mm	10D - 1 1/16"
V6 3.8L (231") 5 Vel.	90-92	EJ-F29B3				X	EC-F23P3	48	11 9/16" - 293mm	10D - 1 1/16"
V6 3.8L (231") SC (Supercargado), 5 Vel.	90-93	EJ-F28C							11 1/8" - 282mm	10D - 1 1/16"
V6 3.8L (231") SC (Supercargado), 5 Vel. (Con balero p/CSC)	94-95	EJ-F29B							11 9/16" - 293mm	10D - 1 1/16"
V6 3.8L (231") SC (Supercargado), 5 Vel.	94-95	EJ-F29B3				X	EC-F23P3	48	11 9/16" - 293mm	10D - 1 1/16"
<b>Topaz</b>										
L4 2.3L OHV, 4 Vel.	84-88	EJ-F22A							8 1/2" - 216mm	20D - 20.1 x 23.1
<b>Topaz GS</b>										
L4 2.3L SOHC, 5 Vel. (Sin casquillo Candelero, Collarín Standard)	88-94	EJ-F22B							8 1/2" - 216mm	20D - 20.1 x 23.1
<b>Topaz GL</b>										
L4 2.3L SOHC, 5 Vel. (Sin casquillo Candelero, Collarín Standard)	88-94	EJ-F22B							8 1/2" - 216mm	20D - 20.1 x 23.1
<b>FORD - PICK-UP / CAMIONETA</b>										
<b>Aerostar</b>										
L4 2.3L (Con balero p/CSC)	86-87	EJ-F23N							8 7/8" - 225mm	23D - 23.1 x 26.1
L4 2.3L	86-87	EJ-F23N3				X	EC-F23N3	47	8 7/8" - 225mm	23D - 23.1 x 26.1
V6 2.8L (Con balero p/CSC)	86	EJ-F23N							8 7/8" - 225mm	23D - 23.1 x 26.1
V6 2.8L	86	EJ-F23N3				X	EC-F23N3	47	8 7/8" - 225mm	23D - 23.1 x 26.1
V6 3.0L (Con balero p/CSC)	86-87	EJ-F23N							8 7/8" - 225mm	23D - 23.1 x 26.1
V6 3.0L	86-87	EJ-F23N3				X	EC-F23N3	47	8 7/8" - 225mm	23D - 23.1 x 26.1
V6 3.0L (Con balero p/CSC)	88-92	EJ-F23P							8 7/8" - 225mm	23D - 23.1 x 26.1
V6 3.0L	88-92	EJ-F23P3				X	EC-F23P3	48	8 7/8" - 225mm	23D - 23.1 x 26.1
V6 3.0L (Con balero p/CSC)	93-95	EJ-F23Q							8 7/8" - 225mm	23D - 23.1 x 26.1
V6 3.0L	93-95	EJ-F23Q3				X	EC-F29A3	48	8 7/8" - 225mm	23D - 23.1 x 26.1
<b>Bronco I</b>										
V6 3.8L (231")	83	EJ-F25F							10" - 254mm	10D - 1 1/16"
V6 4.2L (255") (Con balero p/CSC)	97-98	EJ-F29C		X					11 7/16" - 290mm	10D - 1 1/16"
V6 4.2L (255")	97-98	EJ-F29C3		X	X		EC-F29A3	48	11 7/16" - 290mm	10D - 1 1/16"
L6 4.9L (300")	80-82	EJ-F25J							10" - 254mm	10D - 1 1/16"
L6 4.9L (300")	80-82	EJ-F28F							10 15/16" - 278mm	10D - 1 1/16"



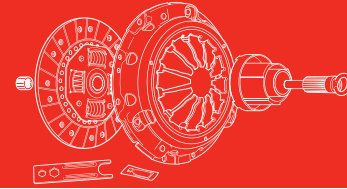

APLICACIÓN

01

NÚMERO DE PARTE

MODULAR

AUTO-AJUSTABLE

VOLANTE BILMASA

COLL. HID. INCLUIDO

NÚMERO DE IMAGEN COLL. HID.

PÁGINA DE IMAGEN COLL. HID.

DIÁMETRO

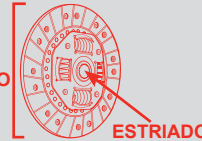

ESTRIADO

### FORD - PICK-UP / CAMIONETA

Continuación

#### Bronco I

Continuación

L6 4.9L (300") (Accionamiento Hidráulico)	83	EJ-F25F							10" - 254mm	10D - 1 1/16"
L6 4.9L (300") (Accionamiento Mecánico)	83	EJ-F28G							10 15/16" - 278mm	10D - 1 1/16"
L6 4.9L (300")	84-86	EJ-F28H							10 15/16" - 278mm	10D - 1 1/16"
L6 4.9L (300")	84-87	EJ-F25F							10" - 254mm	10D - 1 1/16"
L6 4.9L (300") 5 Vel. (Con balero p/CSC)	88-92	EJ-F25K							10" - 254mm	10D - 1 1/16"
L6 4.9L (300") 5 Vel.	88-92	EJ-F25K3				X	EC-F23P3	48	10" - 254mm	10D - 1 1/16"
L6 4.9L (300") 5 Vel.	88-92	EJ-F28K							11" - 280mm	10D - 1 1/16"
L6 4.9L (300")	91	EJ-F25F							10" - 254mm	10D - 1 1/16"
L6 4.9L (300") 4 Vel.	92-93	EJ-F25F							10" - 254mm	10D - 1 1/16"
V8 5.0L (302")	80-82	EJ-F25J							10" - 254mm	10D - 1 1/16"
V8 5.0L (302")	80-83	EJ-F28G							10 15/16" - 278mm	10D - 1 1/16"
V8 5.0L (302") (Versión 10")	84-86	EJ-F25F							10" - 254mm	10D - 1 1/16"
V8 5.0L (302") (versión 11")	84-86	EJ-F28H							10 15/16" - 278mm	10D - 1 1/16"
V8 5.0L (302") 5 Vel.	88-92	EJ-F28K							11" - 280mm	10D - 1 1/16"
V8 5.8L (351")	84-86	EJ-F25F							10" - 254mm	10D - 1 1/16"
V8 5.8L (351")	87	EJ-F28H							10 15/16" - 278mm	10D - 1 1/16"
V8 5.8L (351") 5 Vel.	88-92	EJ-F28K							11" - 280mm	10D - 1 1/16"
V8 6.9L (420") Diesel (Versión 11")	83-86	EJ-F28J							11" - 280mm	10D - 22.6 x 28
V8 6.9L (420") Diesel (Versión 12")	83-87	EJ-F30C							11 13/16" - 300mm	10D - 1 1/16"
V8 6.9L (420") Diesel, Volante Sólido, 4 Vel.	87	EJ-F28J							11" - 280mm	10D - 22.6 x 28
V8 6.9L (420") Diesel (Versión 12"), Volante Sólido	87	EJ-F30C							11 13/16" - 300mm	10D - 1 1/16"
V8 7.5L (460") (versión 12")	83-87	EJ-F30C							11 13/16" - 300mm	10D - 1 1/16"
V8 7.5L (460")	93-97	EJ-F31A							12 1/4" - 311mm	10D - 1 1/4"

#### Bronco II

L4 2.0L Diesel	84	EJ-F23S							8 7/8" - 225mm	23D - 23.1 x 26.1
L4 2.0L Diesel, (Con balero p/CSC)	85-87	EJ-F23N							8 7/8" - 225mm	23D - 23.1 x 26.1
L4 2.0L Diesel,	85-87	EJ-F23N3				X	EC-F23N3	47	8 7/8" - 225mm	23D - 23.1 x 26.1
L4 2.3L	84	EJ-F23S							8 7/8" - 225mm	23D - 23.1 x 26.1
L4 2.3L (Con balero p/CSC)	85-87	EJ-F23N							8 7/8" - 225mm	23D - 23.1 x 26.1
L4 2.3L	85-87	EJ-F23N3				X	EC-F23N3	47	8 7/8" - 225mm	23D - 23.1 x 26.1
V6 2.8L	84	EJ-F23S							8 7/8" - 225mm	23D - 23.1 x 26.1
V6 2.8L (Con balero p/CSC)	85	EJ-F23N							8 7/8" - 225mm	23D - 23.1 x 26.1
V6 2.8L	85	EJ-F23N3				X	EC-F23N3	47	8 7/8" - 225mm	23D - 23.1 x 26.1
V6 2.9L (Con balero p/CSC)	86-87	EJ-F23N							8 7/8" - 225mm	23D - 23.1 x 26.1
V6 2.9L	86-87	EJ-F23N3				X	EC-F23N3	47	8 7/8" - 225mm	23D - 23.1 x 26.1

#### Courier

L4 1.6L 92HP, OHC, 8V, 5 Vel.	01-09	EJ-F19A				X	EC-F19A	47	7 1/2" - 190mm	17D - 17.0 x 20.0
-------------------------------	-------	---------	--	--	--	---	---------	----	----------------	-------------------

#### Custom XLT

V8 5.0L (302") 4 Vel.	91-97	EJ-F28B							11" - 280mm	10D - 1 1/16"
V8 5.8L (351") 4 Vel.	91-97	EJ-F28B							11" - 280mm	10D - 1 1/16"

#### E-100

L6 4.9L (300")	80-82	EJ-F28F							10 15/16" - 278mm	10D - 1 1/16"
----------------	-------	---------	--	--	--	--	--	--	-------------------	---------------



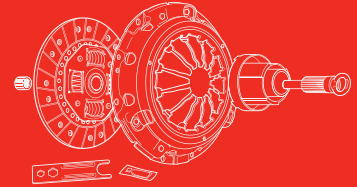

APLICACIÓN	01	NÚMERO DE PARTE	MODULAR	AUTO-AJUSTABLE	VOLANTE BI-MASA	COLL. HID. INCLUIDO	NÚMERO DE IMAGEN COLL. HID.	PÁGINA DE IMAGEN COLL. HID.	DIÁMETRO	ESTRIADO
<b>FORD - PICK-UP / CAMIONETA</b>										
<b>E-100</b>										
L6 4.9L (300")	83	EJ-F28G							10 15/16" - 278mm	10D - 1 1/16"
L6 4.9L (300")	84	EJ-F28H							10 15/16" - 278mm	10D - 1 1/16"
L6 4.9L (300")	83-87	EJ-F25F							10" - 254mm	10D - 1 1/16"
L6 4.9L (300") 5 Vel. (Con balero p/CSC)	88-89	EJ-F25K							10" - 254mm	10D - 1 1/16"
L6 4.9L (300") 5 Vel.	88-92	EJ-F25K3			X		EC-F23P3	48	10" - 254mm	10D - 1 1/16"
L6 4.9L (300")	88-90	EJ-F28K							11" - 280mm	10D - 1 1/16"
V8 5.0L (302")	83-86	EJ-F28G							10 15/16" - 278mm	10D - 1 1/16"
V8 5.8L (351")	80-82	EJ-F28F							10 15/16" - 278mm	10D - 1 1/16"
V8 5.8L (351")	83	EJ-F28G							10 15/16" - 278mm	10D - 1 1/16"
V8 5.8L (351")	84-86	EJ-F28H							10 15/16" - 278mm	10D - 1 1/16"
V8 5.8L (351")	88-90	EJ-F28K							11" - 280mm	10D - 1 1/16"
<b>E-250</b>										
L6 4.9L (300")	80-82	EJ-F28F							10 15/16" - 278mm	10D - 1 1/16"
L6 4.9L (300")	83	EJ-F28G							10 15/16" - 278mm	10D - 1 1/16"
L6 4.9L (300")	84	EJ-F28H							10 15/16" - 278mm	10D - 1 1/16"
L6 4.9L (300")	83-87	EJ-F25F							10" - 254mm	10D - 1 1/16"
L6 4.9L (300") 5 Vel. (Con balero p/CSC)	88-89	EJ-F25K							10" - 254mm	10D - 1 1/16"
L6 4.9L (300") 5 Vel.	88-92	EJ-F25K3			X		EC-F23P3	48	10" - 254mm	10D - 1 1/16"
L6 4.9L (300")	88-90	EJ-F28K							11" - 280mm	10D - 1 1/16"
<b>E-350</b>										
V8 5.0L (302")	83-86	EJ-F28G							10 15/16" - 278mm	10D - 1 1/16"
V8 5.8L (351")	80-82	EJ-F28F							10 15/16" - 278mm	10D - 1 1/16"
V8 5.8L (351")	83	EJ-F28G							10 15/16" - 278mm	10D - 1 1/16"
V8 5.8L (351")	84-86	EJ-F28H							10 15/16" - 278mm	10D - 1 1/16"
V8 5.8L (351")	88-90	EJ-F28K							11" - 280mm	10D - 1 1/16"
<b>Ecosport</b>										
L4 2.0L 5 Vel.	04-07	EJ-F22J				X			8 11/16" - 220mm	17D - 16.93 x 19.9
<b>Explorer</b>										
V6 4.0L (242") (Con balero p/CSC)	93-97	EJ-F25E							9 15/16" - 252mm	23D - 23.1 x 26.1
V6 4.0L (242")	93-97	EJ-F25E3				X	EC-F29A3	48	9 15/16" - 252mm	23D - 23.1 x 26.1
<b>F-100</b>										
L4 2.5L 5 Vel. (Con balero p/CSC)	98-03	EJ-F23D		X					9 1/8" - 232mm	23D - 23.1 x 26.1
L4 2.5L 5 Vel.	98-03	EJ-F23D3		X	X		EC-F29A3	48	9 1/8" - 232mm	23D - 23.1 x 26.1
L4 2.5L 5 Vel. (Con balero p/CSC) Versión NO Autoajustable	98-03	EJ-F23DE							9 1/8" - 232mm	23D - 23.1 x 26.1
L4 2.5L 5 Vel. Versión NO Autoajustable	98-03	EJ-F23DE3				X	EC-F29A3	48	9 1/8" - 232mm	23D - 23.1 x 26.1
V6 3.0L 5 Vel. (Con balero p/CSC)	97-03	EJ-F23D		X					9 1/8" - 232mm	23D - 23.1 x 26.1
V6 3.0L 5 Vel.	97-03	EJ-F23D3		X	X		EC-F29A3	48	9 1/8" - 232mm	23D - 23.1 x 26.1
V6 3.0L 5 Vel. (Con balero p/CSC) Versión NO Autoajustable	97-03	EJ-F23DE							9 1/8" - 232mm	23D - 23.1 x 26.1
V6 3.0L 5 Vel. Versión NO Autoajustable	97-03	EJ-F23DE3				X	EC-F29A3	48	9 1/8" - 232mm	23D - 23.1 x 26.1
V6 3.8L (231") Duratec, 5 Vel.	83	EJ-F25F							10" - 254mm	10D - 1 1/16"
L6 4.9L (300") Accionamiento Hidráulico	83	EJ-F25F							10" - 254mm	10D - 1 1/16"



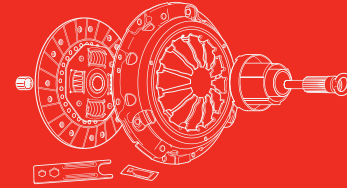

APLICACIÓN

01

NÚMERO DE PARTE

MODULAR

AUTO-AJUSTABLE

VOLANTE

BI-MASA

COLL. HID. INCLUIDO

NÚMERO DE IMAGEN COLL. HID.

PÁGINA DE IMAGEN COLL. HID.

DIÁMETRO

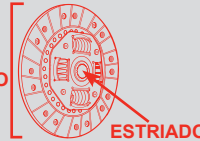

ESTRIADO

### FORD - PICK-UP / CAMIONETA

Continuación

F-100										Continuación	
L6 4.9L (300") Accionamiento Mecánico	83	EJ-F25G								10" - 254mm	10D - 1 1/16"
L6 4.9L (300")	84-86	EJ-F28H								10 15/16" - 278mm	10D - 1 1/16"
L6 4.9L (300")	84-87	EJ-F25F								10" - 254mm	10D - 1 1/16"
L6 4.9L (300") 5 Vel. (Con balero p/CSC)	88-89	EJ-F25K								10" - 254mm	10D - 1 1/16"
L6 4.9L (300") 5 Vel.	88-92	EJ-F25K3			X	EC-F23P3	47			10" - 254mm	10D - 1 1/16"
L6 4.9L (300") 5 Vel.	88-92	EJ-F28K								11" - 280mm	10D - 1 1/16"
L6 4.9L (300") 4 Vel	88-93	EJ-F25F								10" - 254mm	10D - 1 1/16"
V8 5.0L (302")	80-83	EJ-F28G								10 15/16" - 278mm	10D - 1 1/16"
V8 5.0L (302") (Versión 11")	84-86	EJ-F28H								10 15/16" - 278mm	10D - 1 1/16"
L6 5.0L (302") (Versión 10")	84-86	EJ-F25F								10" - 254mm	10D - 1 1/16"
V8 5.0L (302") 5 Vel.	88-92	EJ-F28K								11" - 280mm	10D - 1 1/16"
V8 5.8L (351")	83	EJ-F28G								10 15/16" - 278mm	10D - 1 1/16"
V8 5.8L (351")	84-86	EJ-F25F								10" - 254mm	10D - 1 1/16"
V8 5.8L (351")	87	EJ-F28H								10 15/16" - 278mm	10D - 1 1/16"
V8 5.8L (351") 5 Vel.	88-92	EJ-F28K								11" - 280mm	10D - 1 1/16"
<b>F-100 Custom</b>											
V8 4.7L (286") 4 Vel.	74-79	EJ-F28A4								11 1/16" - 281mm	10D - 1 1/16"
<b>F-100 Ranger</b>											
L4 2.5L 5 Vel. (Con balero p/CSC)	98-03	EJ-F23D		X						9 1/8" - 232mm	23D - 23.1 x 26.1
L4 2.5L 5 Vel.	98-03	EJ-F23D3		X	X	EC-F29A3	48			9 1/8" - 232mm	23D - 23.1 x 26.1
L4 2.5L 5 Vel. (Con balero p/CSC) Versión NO Autoajustable	98-03	EJ-F23DE								9 1/8" - 232mm	23D - 23.1 x 26.1
L4 2.5L 5 Vel. Versión NO Autoajustable	98-03	EJ-F23DE3			X	EC-F29A3	48			9 1/8" - 232mm	23D - 23.1 x 26.1
<b>F-150</b>											
V6 3.8L (231")	83	EJ-F25F								10" - 254mm	10D - 1 1/16"
V6 3.8L (231"), 4 Vel.	91-97	EJ-F28B								11" - 280mm	10D - 1 1/16"
V6 4.2L (258") EFI Dual Port Tritón 5 Vel. (Con balero p/CSC)	97-98	EJ-F29C		X						11 7/16" - 290mm	10D - 1 1/16"
V6 4.2L (258") EFI Dual Port Tritón, 5 Vel.	97-98	EJ-F29C3		X	X	EC-F29A3	48			11 7/16" - 290mm	10D - 1 1/16"
V6 4.2L (258") EFI Dual Port Tritón 5 Vel. (Con balero p/CSC) Versión NO Autoajustable	97-98	EJ-F29CE								11 7/16" - 290mm	10D - 1 1/16"
V6 4.2L (258") EFI Dual Port Tritón 5 Vel. Versión NO Autoajustable	97-98	EJ-F29CE3			X	EC-F29A3	48			11 7/16" - 290mm	10D - 1 1/16"
L6 4.9L (300") 5 Vel.	95-97	EJ-F28E								11 1/16" - 281mm	10D - 1 1/16"
V8 5.0L (302") 4 Vel.	65-91	EJ-F28A4								11 1/16" - 281mm	10D - 1 1/16"
<b>F-150 XL</b>											
V6 4.2L (258") Tritón 5 Vel. (Con balero p/CSC)	98-03	EJ-F29C		X						11 7/16" - 290mm	10D - 1 1/16"
V6 4.2L (258") Tritón 5 Vel.	98-03	EJ-F29C3		X	X	EC-F29A3	48			11 7/16" - 290mm	10D - 1 1/16"
V6 4.2L (258") Tritón 5 Vel. (Con balero p/CSC) Versión NO Autoajustable	97-98	EJ-F29CE								11 7/16" - 290mm	10D - 1 1/16"
V6 4.2L (258") Tritón 5 Vel. Versión NO Autoajustable	97-98	EJ-F29CE3			X	EC-F29A3	48			11 7/16" - 290mm	10D - 1 1/16"
<b>F-200</b>											
V8 5.0L (304"), 4 Vel.	65-93	EJ-F28A4								11 1/16" - 281mm	10D - 1 1/16"
V8 5.8L (351") 4 Vel.	65-91	EJ-F28A4								11 1/16" - 281mm	10D - 1 1/16"



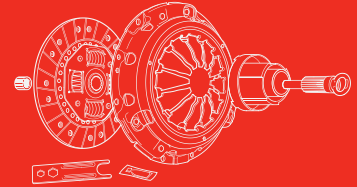

APLICACIÓN	01	NÚMERO DE PARTE	MODULAR	AUTO-AJUSTABLE	VOLANTE BI-MASA	COLL. HID. INCLUIDO	NÚMERO DE IMAGEN COLL. HID.	PÁGINA DE IMAGEN COLL. HID.	DIÁMETRO	ESTRIADO
------------	----	-----------------	---------	----------------	-----------------	---------------------	-----------------------------	-----------------------------	----------	----------

**FORD - PICK-UP / CAMIONETA** Continuación

<b>F-250</b>										
V6 3.8L (231") 4 Vel.	83	EJ-F25F							10" - 254mm	10D - 1 1/16"
V6 4.2L (258") (Con balero p/CSC)	97-98	EJ-F29C		X					11 7/16" - 290mm	10D - 1 1/16"
V6 4.2L (258")	97-98	EJ-F29C3		X	X	EC-F29A3	48		11 7/16" - 290mm	10D - 1 1/16"
V6 4.2L (258") (Con balero p/CSC) Versión NO Autoajustable	97-98	EJ-F29CE							11 7/16" - 290mm	10D - 1 1/16"
V6 4.2L (258") Versión NO Autoajustable	97-98	EJ-F29CE3			X	EC-F29A3	48		11 7/16" - 290mm	10D - 1 1/16"
V8 4.6L (280") Tritón 5 Vel. (Con balero p/CSC)	98-06	EJ-F29C		X					11 7/16" - 290mm	10D - 1 1/16"
V8 4.6L (280") Tritón 5 Vel.	98-06	EJ-F29C3		X	X	EC-F29A3	48		11 7/16" - 290mm	10D - 1 1/16"
V8 4.6L (280") Tritón 5 Vel. (Con balero p/CSC) Versión NO Autoajustable	98-06	EJ-F29CE							11 7/16" - 290mm	10D - 1 1/16"
V8 4.6L (280") Tritón 5 Vel. Versión NO Autoajustable	98-06	EJ-F29CE3			X	EC-F29A3	48		11 7/16" - 290mm	10D - 1 1/16"
L6 4.9L (300")	80-82	EJ-F28F							10 15/16" - 278mm	10D - 1 1/16"
L6 4.9L (300") (Accionamiento Mecánico)	83	EJ-F28G							10 15/16" - 278mm	10D - 1 1/16"
L6 4.9L (300") (Accionamiento Hidráulico)	83	EJ-F25F							10" - 254mm	10D - 1 1/16"
L6 4.9L (300")	84-87	EJ-F25F							10" - 254mm	10D - 1 1/16"
L6 4.9L (300") 5 Vel. (Con balero p/CSC)	88-89	EJ-F25K							10" - 254mm	10D - 1 1/16"
L6 4.9L (300") 5 Vel.	88-92	EJ-F25K3			X	EC-F23P3	48		10" - 254mm	10D - 1 1/16"
L6 4.9L (300") 5 Vel.	88-92	EJ-F28K							11" - 280mm	10D - 1 1/16"
L6 4.9L (300") 4 Vel.	88-93	EJ-F25F							10" - 254mm	10D - 1 1/16"
V8 5.0L (302") 4 Vel.	65-91	EJ-F28A4							11 1/16" - 281mm	10D - 1 1/16"
V8 5.0L (302") 4 Vel.	91-97	EJ-F28B							11" - 280mm	10D - 1 1/16"
V8 5.8L (351") 4 Vel.	65-91	EJ-F28A4							11 1/16" - 281mm	10D - 1 1/16"
V8 5.8L (351") 4 Vel.	92-97	EJ-F28B							11" - 280mm	10D - 1 1/16"
V8 7.5L (460")	93-97	EJ-F31A							12 1/4" - 311mm	10D - 1 1/4"
<b>F-250 Lobo</b>										
V8 5.8L (351") 210HP 4 Vel.	95	EJ-F28B							11" - 280mm	10D - 1 1/16"
<b>F-250 XL, XLT 4x2 y 4x4</b>										
V8 4.6L (280") Tritón 5 Vel. (Con balero p/CSC)	98-06	EJ-F29C		X					11 7/16" - 290mm	10D - 1 1/16"
V8 4.6L (280") Tritón 5 Vel.	98-06	EJ-F29C3		X	X	EC-F29A3	48		11 7/16" - 290mm	10D - 1 1/16"
V8 4.6L (280") Tritón 5 Vel. (Con balero p/CSC) Versión NO Autoajustable	98-06	EJ-F29CE							11 7/16" - 290mm	10D - 1 1/16"
V8 4.6L (280") Tritón 5 Vel. Versión NO Autoajustable	98-06	EJ-F29CE3			X	EC-F29A3	48		11 7/16" - 290mm	10D - 1 1/16"
<b>F-350</b>										
V8 4.7L (286") 4 Vel.	65-91	EJ-F28A4							11 1/16" - 281mm	10D - 1 1/16"
V8 5.0L (302") 4 Vel.	65-91	EJ-F28A4							11 1/16" - 281mm	10D - 1 1/16"
V8 5.8L (351")	65-91	EJ-F28A4							11 1/16" - 281mm	10D - 1 1/16"
V8 6.9L (420") Diesel (Versión 11")	83-86	EJ-F28J							11" - 280mm	10D - 22.6 x 28
V8 6.9L (420") Diesel (Versión 12")	83-87	EJ-F30C							11 13/16" - 300mm	10D - 1 1/16"
V8 6.9L (420") Diesel Volante Sólido 4 Vel.	87	EJ-F28J							11" - 280mm	10D - 22.6 x 28
V8 6.9L (420") Diesel (Versión 12") Volante Sólido	87	EJ-F30C							11 13/16" - 300mm	10D - 1 1/16"
V8 7.5L (456") (Versión 12")	93-97	EJ-F30C							11 13/16" - 300mm	10D - 1 1/16"



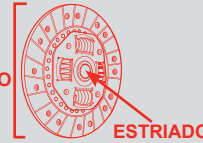
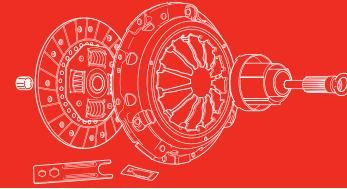

APLICACIÓN

01

NÚMERO DE PARTE

MODULAR

AUTO-AJUSTABLE

VOLANTE

BI-MASA

COLL. HID. INCLUIDO

NÚMERO DE IMAGEN

COLL. HID.

PÁGINA DE IMAGEN

COLL. HID.

DIÁMETRO

ESTRIADO

### FORD - PICK-UP / CAMIONETA

Continuación

#### F-350 XL

V8 5.4L (328") Tritón Transm. T4050	95-97	EJ-F31B		X					11 15/16" - 303mm	10D - 1 1/4"
V8 5.4L (328") Tritón Transm. T4050 Versión NO Autoajustable	95-97	EJ-F31BE							12 3/16" - 310mm	10D - 1 1/4"
V8 5.8L (351") 4 Vel.	95-97	EJ-F28F							10 15/16" - 278mm	10D - 1 1/16"

#### F-350 XLT

V8 5.8L (351") 4 Vel.	91-97	EJ-F28B							11" - 280mm	10D - 1 1/16"
-----------------------	-------	---------	--	--	--	--	--	--	-------------	---------------

#### F-350 Super Duty XL

V8 5.4L (328") Tritón 5 Vel.	99-03	EJ-F31B		X					11 15/16" - 303mm	10D - 1 1/4"
V8 5.4L (328") Tritón 5 Vel. Versión NO autoajustable	99-03	EJ-F31BE							12 3/16" - 310mm	10D - 1 1/4"
V8 5.8L (351") Tritón 5 Vel. (Con balero p/CSC)	98	EJ-F30B							11 9/16" - 295mm	10D - 1 1/16"
V8 5.8L (351") Tritón 5 Vel.	98	EJ-F30B3				X	EC-F29A3	48	11 9/16" - 295mm	10D - 1 1/16"
V8 7.3L (444") Turbo Diesel Tritón, 5 Vel.	93->>	EJ-F30D							11 13/16" - 300mm	10D - 1 1/4"
V8 7.3L (444") Turbo Diesel Tritón 5 Vel. (Incluye Volante Sólido)	93->>	EJ-F30ES							11 7/8" - 302mm	10D - 1 1/4"

#### F-350 Super Duty XLT

V8 5.4L (328"), Tritón, 5 Vel.	99-03	EJ-F31B		X					11 15/16" - 303mm	10D - 1 1/4"
V8 5.4L (328"), Tritón, 5 Vel. Versión NO autoajustable	99-03	EJ-F31BE							12 3/16" - 310mm	10D - 1 1/4"

#### F-450

L6 5.0L (302")	80-83	EJ-F28G							10 15/16" - 278mm	10D - 1 1/16"
V8 5.0L (302"), (Versión 11")	84-86	EJ-F28H							10 15/16" - 278mm	10D - 1 1/16"
V8 5.0L (302"), (Versión 10")	84-86	EJ-F25F							10" - 254mm	10D - 1 1/16"
V8 5.0L (302"), 5 Vel.	88-92	EJ-F28K							11" - 280mm	10D - 1 1/16"
V8 5.8L (351")	83	EJ-F28G							10 15/16" - 278mm	10D - 1 1/16"
V8 5.8L (351")	84-86	EJ-F25F							10" - 254mm	10D - 1 1/16"
V8 5.8L (351")	87	EJ-F28H							10 15/16" - 278mm	10D - 1 1/16"
V8 5.8L (351"), 5 Vel.	88-92	EJ-F28K							11" - 280mm	10D - 1 1/16"
V8 5.8L (351"), MPFI, 4 Vel.	98	EJ-F28F							10 15/16" - 278mm	10D - 1 1/16"
V8 6.9L (420") Diesel (Versión 11")	83-86	EJ-F28J							11" - 280mm	10D - 22.6 x 28
V8 6.9L (420") Diesel (Versión 12")	83-87	EJ-F30C							11 13/16" - 300mm	10D - 1 1/16"
V8 6.9L (420") Diesel, Volante Sólido, 4 Vel.	87	EJ-F28J							11" - 280mm	10D - 22.6 x 28
V8 6.9L (420") Diesel (Versión 12"), Volante Sólido	87	EJ-F30C							11 13/16" - 300mm	10D - 1 1/16"
V8 6.9L (420") Diesel (Versión 11")	83	EJ-F28J							11" - 280mm	10D - 22.6 x 28
V8 7.3L (444"), Power Stroke	94-98	EJ-F31D							12 3/16" - 310mm	10D - 1 1/4"
V8 7.5L (456") (versión 12")	83-87	EJ-F30C							11 13/16" - 300mm	10D - 1 1/16"
V8 7.5L (456")	93-97	EJ-F31A							12 1/4" - 311mm	10D - 1 1/4"

#### F-450 Super Duty XL

V10 6.8L (413"), Tritón, 5 Vel.	99-03	EJ-F31C		X					12 5/16" - 312mm	10D - 1 1/4"
V10 6.8L (413"), Tritón, 5 Vel. Versión NO autoajustable	99-03	EJ-F31CE							12" - 305mm	10D - 1 1/4"
V8 7.3L (444"), Turbo Diesel, Tritón, 5 Vel.	93->>	EJ-F30D							11 13/16" - 300mm	10D - 1 1/4"
V8 7.3L (444"), Turbo Diesel, Tritón, 5 Vel. (Incluye Volante Sólido)	93->>	EJ-F30ES							11 7/8" - 302mm	10D - 1 1/4"



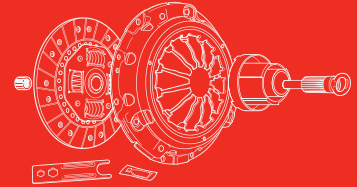

APLICACIÓN	01	NÚMERO DE PARTE	MODULAR	AUTO-AJUSTABLE	VOLANTE BI-MASA	COLL. HID. INCLUIDO	NÚMERO DE IMAGEN COLL. HID.	PÁGINA DE IMAGEN COLL. HID.	DIÁMETRO	ESTRIADO
------------	----	-----------------	---------	----------------	-----------------	---------------------	-----------------------------	-----------------------------	----------	----------

**FORD - PICK-UP / CAMIONETA** Continuación

<b>F-450 Super Duty</b>										
V8 6.0L (368"), Diesel, Super Duty	04->>	EJ-F33H		X					13" - 330mm	10D - 1 3/8"
V8 6.0L (368"), Diesel, Super Duty (Incluye Volante Sólido)	04->>	EJ-F33I		X					13" - 330mm	10D - 1 3/8"
V8 7.3L ( 444"), Diesel, Power Stroke, 6 Vel., Transm. WR-ZF	98-03	EJ-F33F							13" - 330mm	10D - 1 3/8"
V8 7.3L ( 444"), Diesel, Power Stroke, 6 Vel., Transm. WR-ZF, (Incluye Volante Sólido)	98-03	EJ-F33G							13" - 330mm	10D - 1 3/8"
V8 7.5L ( 460") 4 Vel.	98-00	EJ-F31A							12 1/4" - 311mm	10D - 1 1/4"
<b>F-550 XL</b>										
V10 6.8L (414"), MPFI, Tritón, 5 Vel.	97-98	EJ-F31C		X					12 5/16" - 312mm	10D - 1 1/4"
V10 6.8L (414"), MPFI, Tritón, 5 Vel., Versión NO Autoajustable	97-98	EJ-F31CE							12" - 305mm	10D - 1 1/4"
<b>F-550 Super Duty</b>										
V8 6.0L (368"), Diesel, Super Duty	04->>	EJ-F33H		X					13" - 330mm	10D - 1 3/8"
V8 6.0L (368"), Diesel, Super Duty (Incluye Volante Sólido)	04->>	EJ-F33I		X					13" - 330mm	10D - 1 3/8"
<b>Lobo HD</b>										
V8 5.0L (302")	91-97	EJ-F28B2							11" - 280mm	10D -
V8 5.8L (351")	91-97	EJ-F28B2							11" - 280mm	10D -
<b>Ranger</b>										
L4 2.0L Diesel	83-84	EJ-F23S							8 7/8" - 225mm	23D - 23.1 x 26.1
L4 2.0L	83-84	EJ-F23S							8 7/8" - 225mm	23D - 23.1 x 26.1
L4 2.0L (Con balero p/CSC)	85-87	EJ-F23N							8 7/8" - 225mm	23D - 23.1 x 26.1
L4 2.0L	85-87	EJ-F23N3			X	EC-F23N3	47		8 7/8" - 225mm	23D - 23.1 x 26.1
L4 2.0L (Con balero p/CSC)	88	EJ-F23P							8 7/8" - 225mm	23D - 23.1 x 26.1
L4 2.0L	88	EJ-F23P3			X	EC-F23P3	48		8 7/8" - 225mm	23D - 23.1 x 26.1
L4 2.3L	83-84	EJ-F23S							8 7/8" - 225mm	23D - 23.1 x 26.1
L4 2.3L (Con balero p/CSC)	85-87	EJ-F23N							8 7/8" - 225mm	23D - 23.1 x 26.1
L4 2.3L	85-87	EJ-F23N3			X	EC-F23N3	47		8 7/8" - 225mm	23D - 23.1 x 26.1
L4 2.3L (Con balero p/CSC)	93-95	EJ-F23Q							8 7/8" - 225mm	23D - 23.1 x 26.1
L4 2.3L	93-95	EJ-F23Q3			X	EC-F29A3	48		8 7/8" - 225mm	23D - 23.1 x 26.1
L4 2.3L (Con balero p/CSC)	96-04	EJ-F23D		X					9 1/8" - 232mm	23D - 23.1 x 26.1
L4 2.3L	96-04	EJ-F23D3		X	X	EC-F29A3	48		9 1/8" - 232mm	23D - 23.1 x 26.1
L4 2.3L (Con balero p/CSC), Versión NO Autoajustable	96-04	EJ-F23DE							9 1/8" - 232mm	23D - 23.1 x 26.1
L4 2.3L, Versión NO Autoajustable	96-04	EJ-F23DE3			X	EC-F29A3	48		9 1/8" - 232mm	23D - 23.1 x 26.1
L4 2.3L (Con balero p/CSC)	02-03	EJ-F23D		X					9 1/8" - 232mm	23D - 23.1 x 26.1
L4 2.3L	02-03	EJ-F23D3		X	X	EC-F29A3	48		9 1/8" - 232mm	23D - 23.1 x 26.1
L4 2.3L, (Con balero p/CSC) Versión NO Autoajustable	02-03	EJ-F23DE							9 1/8" - 232mm	23D - 23.1 x 26.1
L4 2.3L, Versión NO Autoajustable	02-03	EJ-F23DE3			X	EC-F29A3	48		9 1/8" - 232mm	23D - 23.1 x 26.1
L4 2.3L (Con balero p/CSC)	88-92	EJ-F23P							8 7/8" - 225mm	23D - 23.1 x 26.1
L4 2.3L	88-92	EJ-F23P3			X	EC-F23P3	48		8 7/8" - 225mm	23D - 23.1 x 26.1
L4 2.5L (Con balero p/CSC)	98-01	EJ-F23D		X					9 1/8" - 232mm	23D - 23.1 x 26.1
L4 2.5L	98-01	EJ-F23D3		X	X	EC-F29A3	48		9 1/8" - 232mm	23D - 23.1 x 26.1



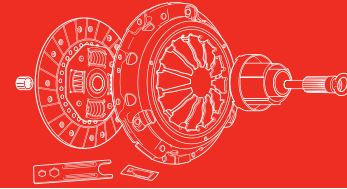

APLICACIÓN

01

NÚMERO DE PARTE

MODULAR

AUTO-AJUSTABLE

VOLANTE

BI-MASA

COLL. HID. INCLUIDO

NÚMERO DE IMAGEN COLL. HID.

PÁGINA DE IMAGEN COLL. HID.

DIÁMETRO

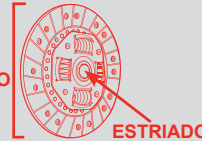

ESTRIADO

### FORD - PICK-UP / CAMIONETA

Continuación

#### Ranger

Continuación

L4 2.5L (Con balero p/CSC), Versión NO Autoajustable	96-04	EJ-F23DE							9 1/8" - 232mm	23D - 23.1 x 26.1
L4 2.5L, Versión NO Autoajustable	96-04	EJ-F23DE3				X	EC-F29A3	48	9 1/8" - 232mm	23D - 23.1 x 26.1
V6 2.8L	83-84	EJ-F23S							8 7/8" - 225mm	23D - 23.1 x 26.1
V6 2.9L (Con balero p/CSC)	88-92	EJ-F23P							8 7/8" - 225mm	23D - 23.1 x 26.1
V6 2.9L)	88-92	EJ-F23P3				X	EC-F23P3	48	8 7/8" - 225mm	23D - 23.1 x 26.1
V6 3.0L (Con balero p/CSC)	93-95	EJ-F23Q							8 7/8" - 225mm	23D - 23.1 x 26.1
V6 3.0L	93-95	EJ-F23Q3				X	EC-F29A3	48	8 7/8" - 225mm	23D - 23.1 x 26.1
V6 4.0L (243") (Con balero p/CSC)	90-92	EJ-F25D							9 15/16" - 252mm	23D - 23.1 x 26.1
V6 4.0L (243")	90-92	EJ-F25D3				X	EC-F23P3	48	9 15/16" - 252mm	23D - 23.1 x 26.1
V6 4.0L (243") (Con balero p/CSC)	93-97	EJ-F25E							9 15/16" - 252mm	23D - 23.1 x 26.1
V6 4.0L (243")	93-97	EJ-F25E3				X	EC-F29A3	48	9 15/16" - 252mm	23D - 23.1 x 26.1
V6 4.0L (243")	01-04	EJ-MA26A							10 1/8" - 257mm	23D - 23.1 x 26.1

#### Ranger XL

L4 2.3L (Con balero p/CSC)	88-92	EJ-F23P							8 7/8" - 225mm	23D - 23.1 x 26.1
L4 2.3L	88-92	EJ-F23P3				X	EC-F23P3	48	8 7/8" - 225mm	23D - 23.1 x 26.1
L4 2.3L 5 Vel. (Con balero p/CSC)	96-97	EJ-F23D	X						9 1/8" - 232mm	23D - 23.1 x 26.1
L4 2.3L 5 Vel.	96-97	EJ-F23D3	X	X		EC-F29A3	48	9 1/8" - 232mm	23D - 23.1 x 26.1	
L4 2.3L (Con balero p/CSC), Versión NO Autoajustable	96-04	EJ-F23DE							9 1/8" - 232mm	23D - 23.1 x 26.1
L4 2.3L, Versión NO Autoajustable	96-04	EJ-F23DE3				X	EC-F29A3	48	9 1/8" - 232mm	23D - 23.1 x 26.1
L4 2.3L (Con balero p/CSC)	02-06	EJ-F23D	X						9 1/8" - 232mm	23D - 23.1 x 26.1
L4 2.3L 5 Vel.	02-06	EJ-F23D3	X	X		EC-F29A3	48	9 1/8" - 232mm	23D - 23.1 x 26.1	
L4 2.3L, (Con Balero p/CSC) Versión NO Autoajustable	02-06	EJ-F23DE							9 1/8" - 232mm	23D - 23.1 x 26.1
L4 2.3L, Versión NO Autoajustable	02-06	EJ-F23DE3				X	EC-F29A3	48	9 1/8" - 232mm	23D - 23.1 x 26.1
L4 2.5L (Con balero p/CSC)	98-01	EJ-F23D	X						9 1/8" - 232mm	23D - 23.1 x 26.1
L4 2.5L	98-01	EJ-F23D3	X	X		EC-F29A3	48	9 1/8" - 232mm	23D - 23.1 x 26.1	
L4 2.5L (Con balero p/CSC), Versión NO Autoajustable	96-04	EJ-F23DE							9 1/8" - 232mm	23D - 23.1 x 26.1
L4 2.5L, Versión NO Autoajustable	96-04	EJ-F23DE3				X	EC-F29A3	48	9 1/8" - 232mm	23D - 23.1 x 26.1
V6 3.0L 5 Vel. (Con balero p/CSC)	96-02	EJ-F23D	X						9 1/8" - 232mm	23D - 23.1 x 26.1
V6 3.0L 5 Vel.	96-02	EJ-F23D3	X	X		EC-F29A3	48	9 1/8" - 232mm	23D - 23.1 x 26.1	
V6 3.0L 5 Vel. (Con balero p/CSC) Versión NO Autoajustable	96-02	EJ-F23DE							9 1/8" - 232mm	23D - 23.1 x 26.1
V6 3.0L 5 Vel. Versión NO Autoajustable	96-02	EJ-F23DE3				X	EC-F29A3	48	9 1/8" - 232mm	23D - 23.1 x 26.1

### FORD - MICROBÚS

#### Microbús P350

V8 5.8L (351")	91-97	EJ-F28B							11" - 280mm	10D - 1 1/16"
----------------	-------	---------	--	--	--	--	--	--	-------------	---------------

#### Vanette

V8 5.8L (351"), 4 Vel.	91-97	EJ-F28B							11" - 280mm	10D - 1 1/16"
------------------------	-------	---------	--	--	--	--	--	--	-------------	---------------

### GEO

#### Tracker

L4 1.6L	89-97	EJ-GE20A							7 7/8" - 200mm	20D - 20.0 x 22.5
---------	-------	----------	--	--	--	--	--	--	----------------	-------------------



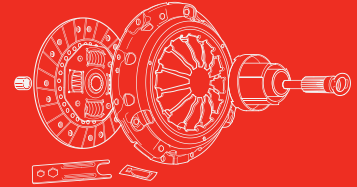

APLICACIÓN	01	NÚMERO DE PARTE	MODULAR	AUTO-AJUSTABLE	VOLANTE BI-MASA	COLL. HID. INCLUIDO	NÚMERO DE IMAGEN COLL. HID.	PÁGINA DE IMAGEN COLL. HID.	DIÁMETRO	ESTRIADO
<b>GEO</b>										
<b>Tracker 4x4 / 4x2</b>										
L4 2.0L DOHC, 16V, 5 Vel.	99-03	EJ-GE20C							7 7/8" - 200mm	20D - 20.0 x 22.5
<b>HONDA - AUTOMÓVIL NUEVAS APLICACIONES (*)</b>										
<b>Accord</b>										
L4 2.0L	86-89	EJ-H21A							8 1/4" - 210mm	26D - 20.0 x 21.9
L4 2.2L	90-97	EJ-H23A							8 7/8" - 225mm	24D - 23.0 x 26.6
L4 2.3L	98-01	EJ-H23A							8 7/8" - 225mm	24D - 23.0 x 26.6
<b>Civic</b>										
L4 1.3L / 1.5L	84-87	EJ-H19A							7 1/2" - 190mm	19D - 18 x 20.3
L4 1.5L	90-91	EJ-H21C							8 1/4" - 210mm	20D - 20.0 x 21.9
L4 1.5L	92-95	EJ-H21B							8 1/4" - 210mm	20D - 20.0 x 21.9
L4 1.6L	90-91	EJ-H21C							8 1/4" - 210mm	20D - 20.0 x 21.9
L4 1.6L	92-95	EJ-H21B							8 1/4" - 210mm	20D - 20.0 x 21.9
<b>Civic Del Sol</b>										
L4 1.5L	93-94	EJ-H21B							8 1/4" - 210mm	20D - 20.0 x 21.9
L4 1.5L	97	EJ-H21B							8 1/4" - 210mm	20D - 20.0 x 21.9
L4 1.6L	93-95	EJ-H21B							8 1/4" - 210mm	20D - 20.0 x 21.9
<b>Civic Coupé</b>										
L4 1.6L 5 Vel.	97-00	EJ-H21B							8 1/4" - 210mm	20D - 20.0 x 21.9
L4 1.7L SOHC, 16V, 5 Vel.	01-05	EJ-H21E							8 1/4" - 210mm	20D - 20.1 x 21.9
<b>Civic Sedán</b>										
L4 1.6L 5 Vel.	97-00	EJ-H21B							8 1/4" - 210mm	20D - 20.0 x 21.9
L4 1.7L SOHC, 16V, 5 Vel.	01-05	EJ-H21E							8 1/4" - 210mm	20D - 20.1 x 21.9
*LX, EX L4 1.8 Lts. 140 HP	06-07	EJ-H22C								
<b>Civic SIR</b>										
L4 1.6L 160HP	99-00	EJ-H22B							8 11/16" - 220mm	24D - 23.0 x 23.6
<b>CRX</b>										
L4 1.3L	84	EJ-H19A							7 1/2" - 190mm	19D - 18 x 20.3
L4 1.5L	84-87	EJ-H19A							7 1/2" - 190mm	19D - 18 x 20.3
L4 1.5L / 1.6L	92-95	EJ-H21B							8 1/4" - 210mm	20D - 20.0 x 21.9
<b>Prelude</b>										
L4 2.0L	84-87	EJ-H21A							8 1/4" - 210mm	26D - 20.0 x 21.9
<b>HONDA - CAMIONETA</b>										
<b>Passport</b>										
L4 2.6L	94-97	EJ-H24A							9 7/16" - 240mm	24D - 23.0 x 25.5
<b>ISUZU - PICK-UP / CAMIONETA</b>										
<b>Amigo</b>										
L4 2.2L	98-99	EJ-IS24A							9 7/16" - 240mm	24D - 23.0 x 25.6
L4 2.2L	98-00	EJ-H24A							9 7/16" - 240mm	24D - 23.0 x 25.5
L4 2.3L	89-93	EJ-GM22A							8 1/2" - 216mm	24D - 23.0 x 25.6
L4 2.6L	89-94	EJ-H24A							9 7/16" - 240mm	24D - 23.0 x 25.5
<b>Pick-Up</b>										
L4 1.9L	83-87	EJ-IS22A							8 1/2" - 217mm	20D - 23.0 x 25.6
L4 2.2L Turbo Diesel	81-87	EJ-IS22A							8 1/2" - 217mm	20D - 23.0 x 25.6



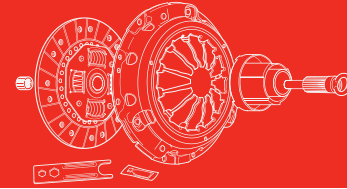

APLICACIÓN	01	NÚMERO DE PARTE	MODULAR	AUTO-AJUSTABLE	VOLANTE	BI-MASA	COLL. HID. INCLUIDO	NÚMERO DE IMAGEN COLL. HID.	PÁGINA DE IMAGEN COLL. HID.	DIÁMETRO	ESTRIADO
<b>ISUZU - PICK-UP / CAMIONETA</b>											
										Continuación	
<b>Pick-Up</b>											
										Continuación	
L4 2.3L	86-95	EJ-IS22A								8 1/2" - 217mm	20D - 23.0 x 25.6
<b>Pick-Up 4x2</b>											
L4 1.8L	81-82	EJ-IS20A								10" - 254mm	24D - 23.0 x 25.6
<b>Pick-Up 4x4</b>											
L4 1.8L	81-94	EJ-IS22A								8 1/2" - 217mm	20D - 23.0 x 25.6
<b>Rodeo</b>											
L4 1.6L	82	EJ-IS20A								10" - 254mm	24D - 23.0 x 25.6
L4 2.0L	82	EJ-IS20A								10" - 254mm	24D - 23.0 x 25.6
L4 2.0L Turbo	84-87	EJ-IS22A								8 1/2" - 217mm	20D - 23.0 x 25.6
L4 2.2L Turbo	84-87	EJ-IS22A								8 1/2" - 217mm	20D - 23.0 x 25.6
L4 2.2L X22SE	98-00	EJ-IS24A								9 7/16" - 240mm	24D - 23.0 x 25.6
L4 2.3L Turbo	84-87	EJ-IS22A								8 1/2" - 217mm	20D - 23.0 x 25.6
L4 2.6L	92-97	EJ-IS24A								9 7/16" - 240mm	24D - 23.0 x 25.6
V6 3.1L	91-92	EJ-GM23E								9 1/4" - 234mm	14D - 21.5 x 25.1
V6 3.2L	93-99	EJ-H24A								9 7/16" - 240mm	24D - 23.0 x 25.5
<b>Rodeo 4x2</b>											
L4 2.6L	90-93	EJ-IS24A								9 7/16" - 240mm	24D - 23.0 x 25.6
<b>Rodeo 4x4</b>											
L4 2.6L	90-93	EJ-IS24A								9 7/16" - 240mm	24D - 23.0 x 25.6
<b>Trooper</b>											
L4 1.9L	84-85	EJ-GM22A								8 1/2" - 216mm	24D - 23.0 x 25.6
L4 2.2L Turbo, Diesel	84	EJ-GM22A								8 1/2" - 216mm	24D - 23.0 x 25.6
L4 2.2L Turbo, Diesel	86-87	EJ-GM22A								8 1/2" - 216mm	24D - 23.0 x 25.6
L4 2.3L	86-87	EJ-GM22A								8 1/2" - 216mm	24D - 23.0 x 25.6
L4 2.6L	87-92	EJ-IS24A								9 7/16" - 240mm	24D - 23.0 x 25.6
<b>ISUZU - CAMIONES NUEVAS APLICACIONES (*)</b>											
<b>ELF</b>											
*ELF 200, 300 L4 3.0 Lts., Diesel	09->>	EJ-IS30A									
*ELF 400, ELF 450, ELF 550, ELF 600 L4, DOCH 16 válvulas, 5.193 cc., enfriado por agua, 190 (HP), Transmisión Manual de 6 Vel., turbo cargado, inyección electrónica de riel común	05->>	EJ-IS33AC									
<b>JEEP</b>											
<b>Cherokee</b>											
L4 2.5L	87-92	EJ-D23C				X				8 7/8" - 225mm	14D - 22.8 x 25.2
L6 4.0L (242")	93	EJ-D26B				X				10 7/16" - 264mm	10D - 1 1/8"
<b>Comanche</b>											
L4 2.5L	87-92	EJ-D23C				X				8 7/8" - 225mm	14D - 22.8 x 25.2
L6 4.0L (242")	87-88	EJ-D26D				X				10 3/8" - 263mm	10D - 1 1/8"
L6 4.2L (258")	87-88	EJ-D26D				X				10 3/8" - 263mm	10D - 1 1/8"
<b>Gladiator</b>											
L4 2.5L 106HP	87-92	EJ-D23M				X				9 3/16" - 233mm	14D - 21.5 x 25.1
L6 2.8L	85-86	EJ-D23I								9 1/4" - 234mm	14D - 21.5 x 25.1



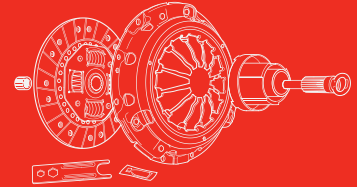

APLICACIÓN	01	NÚMERO DE PARTE	MODULAR	AUTO-AJUSTABLE	VOLANTE BI-MASA	COLL. HID. INCLUIDO	NÚMERO DE IMAGEN COLL. HID.	PÁGINA DE IMAGEN COLL. HID.	DIÁMETRO	ESTRIADO
<b>JEEP</b>										
<b>Grand Cherokee</b>										
L4 2.5L	87-92	EJ-D23C				X			8 7/8" - 225mm	14D - 22.8 x 25.2
<b>Grand Wagoneer</b>										
L4 2.5L	87-92	EJ-D23C				X			8 7/8" - 225mm	14D - 22.8 x 25.2
<b>Jeep</b>										
L4 2.5L	84-86	EJ-D23T							9 1/4" - 234mm	14D - 21.5 x 25.1
L6 4.0L (242")	86	EJ-D26C							10 7/16" - 264mm	10D - 1 1/8"
L6 4.2L (258")	86	EJ-D26C							10 7/16" - 264mm	10D - 1 1/8"
L6 4.2L (258")	89-90	EJ-D26A				X			10 7/16" - 264mm	10D - 1 1/8"
<b>Liberty</b>										
L4 2.4L	02-05	EJ-D23V							9" - 229mm	19D - 22.6x25.3
V6 3.7L (225") 210HP	02-04	EJ-D26G							10 7/16" - 264mm	10D - 1 1/8"
<b>Series CJ</b>										
L4 2.5L	87-92	EJ-D23C				X			8 7/8" - 225mm	14D - 22.8 x 25.2
<b>Serie J</b>										
L4 2.5L 106HP	87-92	EJ-D23M				X			9 3/16" - 233mm	14D - 21.5 x 25.1
L6 2.8L	86	EJ-D23I							9 1/4" - 234mm	14D - 21.5 x 25.1
<b>Wagoneer</b>										
L4 2.5L	87-92	EJ-D23C				X			8 7/8" - 225mm	14D - 22.8 x 25.2
<b>Wrangler</b>										
L4 2.4L OHV	02-05	EJ-D23V							9" - 229mm	19D - 22.6x25.3
L4 2.5L	87	EJ-D23C				X			8 7/8" - 225mm	14D - 22.8 x 25.2
L4 2.5L	88-92	EJ-D23C				X			8 7/8" - 225mm	14D - 22.8 x 25.2
L6 4.0L (242") OHV	93	EJ-D26B				X			10 7/16" - 264mm	10D - 1 1/8"
<b>Wrangler Sahara</b>										
L6 4.0L (242") MPFI, OHV, 5 Vel.	98-06	EJ-D27J							10 7/16" - 265mm	10D - 1 1/8"
<b>Wrangler SE</b>										
L4 2.5L MPFI, OHV, 5 Vel.	94-03	EJ-D23J				X			9 1/4" - 234mm	14D - 21.5 x 25.1
<b>MAZDA - AUTOMÓVIL</b>										
<b>3</b>										
L4 2.3L 160HP, DOHC	06-09	EJ-MA22D							8 7/16" - 215mm	22D - 22.3 x 24.3
<b>323</b>										
L4 1.6L Turbo	87-89	EJ-MA23D							8 7/8" - 225mm	22D - 22.3 x 24.3
<b>6</b>										
L4 2.3L 160HP, DOHC	06-09	EJ-MA22D							8 7/16" - 215mm	22D - 22.3 x 24.3
V6 3.0L 215HP, DOHC	06-09	EJ-MA24B							9 7/16" - 240mm	23D - 22.3x26.2
<b>626</b>										
L4 2.0L Diesel, No Turbo	83-87	EJ-MA23D							8 7/8" - 225mm	22D - 22.3 x 24.3
L4 2.0L Gas, No Turbo	83-87	EJ-MA23D							8 7/8" - 225mm	22D - 22.3 x 24.3
L4 2.2L No Turbo	88-92	EJ-MA23D							8 7/8" - 225mm	22D - 22.3 x 24.3
V6 2.5L	93-02	EJ-F23F							8 7/8" - 225mm	22D - 22.3 x 24.3
<b>GLC</b>										
L4 1.6L Turbo, 4x4	88-89	EJ-MA23D							8 7/8" - 225mm	22D - 22.3 x 24.3

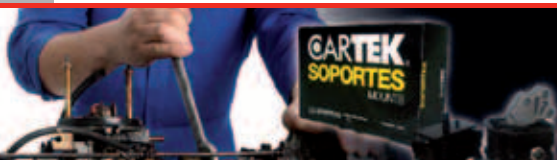

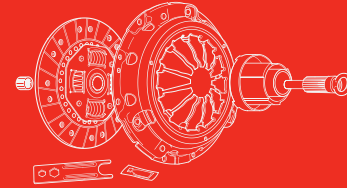

APLICACIÓN

01

NÚMERO DE PARTE

MODULAR

AUTO-AJUSTABLE

VOLANTE

BI-MASA

COLL. HID. INCLUIDO

NÚMERO DE IMAGEN COLL. HID.

PÁGINA DE IMAGEN COLL. HID.

DIÁMETRO

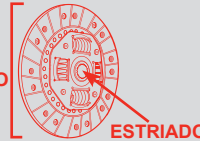

ESTRIADO

### MAZDA - AUTOMÓVIL

Continuación

APLICACIÓN	01	NÚMERO DE PARTE	MODULAR	AUTO-AJUSTABLE	VOLANTE	BI-MASA	COLL. HID. INCLUIDO	NÚMERO DE IMAGEN COLL. HID.	PÁGINA DE IMAGEN COLL. HID.	DIÁMETRO	ESTRIADO
<b>MX-3</b>											
V6 1.8L	92-93	EJ-F23H								8 7/8" - 225mm	22D - 22.3 x 24.3
V6 1.8L	94-95	EJ-MA23D								8 7/8" - 225mm	22D - 22.3 x 24.3
<b>MX-6</b>											
L4 2.0L	83-87	EJ-MA23D								8 7/8" - 225mm	22D - 22.3 x 24.3
L4 2.2L	88-92	EJ-MA23D								8 7/8" - 225mm	22D - 22.3 x 24.3
V6 2.5L	93-97	EJ-F23F								8 7/8" - 225mm	22D - 22.3 x 24.3
<b>MAZDA - PICK-UP / CAMIONETA</b>											
<b>MPV</b>											
L4 2.6L	88-91	EJ-MA25A								9 13/16" - 250mm	23D - 23.5 x 26.5
L4 3.0L	88-91	EJ-MA25A								9 13/16" - 250mm	23D - 23.5 x 26.5
<b>Navajo</b>											
V6 4.0L (242") (Con balero p/CSC)	93-94	EJ-F25E								9 15/16" - 252mm	23D - 23.1 x 26.1
V6 4.0L (242")	93-94	EJ-F25E3				X		EC-F29A3	48	9 15/16" - 252mm	23D - 23.1 x 26.1
<b>Serie B 2000</b>											
L4 2.0L	79-85	EJ-MA22E								8 7/16" - 215mm	22D - 22.3 x 24.0
L4 2.0L	86-87	EJ-MA23D								8 7/8" - 225mm	22D - 22.3 x 24.3
<b>Serie B 2200</b>											
L4 2.2L	87-93	EJ-MA23E								8 7/8" - 225mm	22D - 22.3 x 24.3
<b>Serie B 2300</b>											
L4 2.3L (Con balero p/CSC)	94	EJ-F23Q								8 7/8" - 225mm	23D - 23.1 x 26.1
L4 2.3L	94	EJ-F23Q3				X		EC-F29A3	48	8 7/8" - 225mm	23D - 23.1 x 26.1
L4 2.3L	95-97	EJ-MA23B	X							9 1/16" - 231mm	22D -
L4 2.3L (Con balero p/CSC)	01-06	EJ-F23D	X							9 1/8" - 232mm	23D - 23.1 x 26.1
L4 2.3L	01-06	EJ-F23D3	X	X				EC-F29A3	48	9 1/8" - 232mm	23D - 23.1 x 26.1
L4 2.3L (Con balero p/CSC) Versión NO Autoajustable	01-06	EJ-F23DE								9 1/8" - 232mm	23D - 23.1 x 26.1
L4 2.3L Versión NO Autoajustable	01-06	EJ-F23DE3				X		EC-F29A3	48	9 1/8" - 232mm	23D - 23.1 x 26.1
<b>Serie B 2500</b>											
L4 2.5L (Con balero p/CSC)	98-01	EJ-F23D		X						9 1/8" - 232mm	23D - 23.1 x 26.1
L4 2.5L	98-01	EJ-F23D3	X	X				EC-F29A3	48	9 1/8" - 232mm	23D - 23.1 x 26.1
L4 2.5L (Con balero p/CSC) Versión NO Autoajustable	01-06	EJ-F23DE								9 1/8" - 232mm	23D - 23.1 x 26.1
L4 2.5L Versión NO Autoajustable	01-06	EJ-F23DE3				X		EC-F29A3	48	9 1/8" - 232mm	23D - 23.1 x 26.1
<b>Serie B 2600</b>											
L4 2.6L	87-89	EJ-MA24A								9 7/16" - 240mm	23D - 23 x 26
L4 2.6L FI	89-93	EJ-MA25A								9 13/16" - 250mm	23D - 23.5 x 26.5
<b>Serie B 2600i</b>											
L4 2.6L	87-89	EJ-MA24A								9 7/16" - 240mm	23D - 23 x 26
L4 2.6L FI	89-93	EJ-MA25A								9 13/16" - 250mm	23D - 23.5 x 26.5
<b>Serie B 3000</b>											
V6 3.0L (Con balero p/CSC)	94	EJ-F23Q								8 7/8" - 225mm	23D - 23.1 x 26.1
V6 3.0L	94	EJ-F23Q3				X		EC-F29A3	48	8 7/8" - 225mm	23D - 23.1 x 26.1
V6 3.0L (Con balero p/CSC)	95-96	EJ-F23D	X							9 1/8" - 232mm	23D - 23.1 x 26.1
V6 3.0L	95-96	EJ-F23D3	X	X				EC-F29A3	48	9 1/8" - 232mm	23D - 23.1 x 26.1



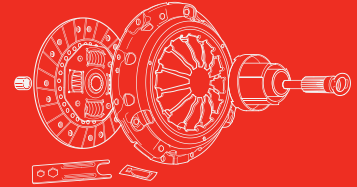

APLICACIÓN	01	NÚMERO DE PARTE	MODULAR	AUTO-AJUSTABLE	VOLANTE BI-MASA	COLL. HID. INCLUIDO	NÚMERO DE IMAGEN COLL. HID.	PÁGINA DE IMAGEN COLL. HID.	DIÁMETRO	ESTRIADO
<b>MAZDA - PICK-UP / CAMIONETA</b>										
<b>Serie B 3000</b>										
V6 3.0L (Con balero p/CSC), Versión NO Autoajustable	95-96	EJ-F23DE							9 1/8" - 232mm	23D - 23.1 x 26.1
V6 3.0L, Versión NO Autoajustable	95-96	EJ-F23DE3			X		EC-F29A3	48	9 1/8" - 232mm	23D - 23.1 x 26.1
V6 3.0L (Con balero p/CSC)	98-06	EJ-F23D	X						9 1/8" - 232mm	23D - 23.1 x 26.1
V6 3.0L	98-06	EJ-F23D3	X	X			EC-F29A3	48	9 1/8" - 232mm	23D - 23.1 x 26.1
V6 3.0L (Con balero p/CSC), Versión NO Autoajustable	98-06	EJ-F23DE							9 1/8" - 232mm	23D - 23.1 x 26.1
V6 3.0L, Versión NO Autoajustable	98-06	EJ-F23DE3			X		EC-F29A3	48	9 1/8" - 232mm	23D - 23.1 x 26.1
<b>Serie B 4000</b>										
V6 4.0L (242") (Con balero p/CSC)	94-98	EJ-F25E							9 15/16" - 252mm	23D - 23.1 x 26.1
V6 4.0L (242")	94-98	EJ-F25E3			X		EC-F29A3	47	9 15/16" - 252mm	23D - 23.1 x 26.1
V6 4.0L (242") (Con balero p/CSC)	00-04	EJ-MA26A							10 1/8" - 257mm	23D - 23.1 x 26.1
<b>MERCURY - AUTOMÓVIL</b>										
<b>Capri</b>										
L4 1.6L Turbo	91-94	EJ-MA23D							8 7/8" - 225mm	22D - 22.3 x 24.3
<b>Cougar</b>										
V6 2.5L	92-02	EJ-F24B			X		EC-F24B	48	9 1/2" - 241mm	23D - 23.1 x 26.1
V6 3.8L (231") (Con balero p/CSC)	94-97	EJ-F29B							11 9/16" - 293mm	10D - 1 1/16"
V6 3.8L (231")	94-97	EJ-F29B3			X		EC-F23P3	48	11 9/16" - 293mm	10D - 1 1/16"
<b>LN7</b>										
L4 1.9L	85-87	EJ-F22A							8 1/2" - 216mm	20D - 20.1 x 23.1
<b>Lynx</b>										
L4 1.9L	85-87	EJ-F22A							8 1/2" - 216mm	20D - 20.1 x 23.1
<b>Mystique</b>										
L4 2.0L 16V 5 Vel.	95-00	EJ-F24C			X		EC-F23J	47	9 7/16" - 240mm	23D - 23.1 x 26.1
V6 2.5L 24V, 5 Vel.	95-00	EJ-F24B			X		EC-F24B	48	9 1/2" - 241mm	23D - 23.1 x 26.1
<b>Sable</b>										
L4 2.5L	86-90	EJ-F22A							8 1/2" - 216mm	20D - 20.1 x 23.1
<b>Tracer</b>										
L4 1.8L	91-94	EJ-F23H							8 7/8" - 225mm	22D - 22.3 x 24.3
<b>MITSUBISHI - AUTOMÓVIL</b>										
<b>Eclipse</b>										
L4 2.0L No-turbo	95-99	EJ-D22C	X						8 11/16" - 220mm	17D
<b>MITSUBISHI - PICK-UP / CAMIONETA NUEVAS APLICACIONES (*)</b>										
<b>Lancer</b>										
*L4 2.0 Lts. EVO IX MR 6 Vel.	06	EJ-MI24B								
*L4 2.0 Lts. 120 HP 5 Vel.	04-07	EJ-MI22B								
*L4 2.0 Lts. 120 HP 5 Vel.	02-03	EJ-MI23E								
*L4 2.0 Lts. 152 HP 5 Vel.	08->>	EJ-MI23C								
*L4 2.4 Lts. RALLIART 5 Vel.	05-06	EJ-MI23D								
<b>Montero</b>										
L4 2.4L	97-99	EJ-D23W							8 7/8" - 225mm	23D - 23.2 x 26.2
L4 2.6L	83-86	EJ-MI23B							8 7/8" - 225mm	23D - 23.0 x 26.0



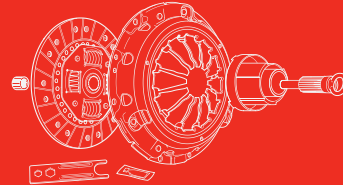

APLICACIÓN	01	NÚMERO DE PARTE	MODULAR	AUTO-AJUSTABLE	VOLANTE	BIMASA	COLL. HID. INCLUIDO	NÚMERO DE IMAGEN COLL. HID.	PÁGINA DE IMAGEN COLL. HID.	DIÁMETRO	
<b>MITSUBISHI - PICK-UP / CAMIONETA NUEVAS APLICACIONES (*)</b>											
Continuación											
<b>Pick-Up</b>											
L4 2.0L	82-86	EJ-D22G								8 1/2" - 216mm	23D - 23.0 x 26.0
L4 2.0L 2WD	83-90	EJ-D22G								8 1/2" - 216mm	23D - 23.0 x 26.0
L4 2.3L Diesel, Turbo	83-85	EJ-MI23B								8 7/8" - 225mm	23D - 23.0 x 26.0
L4 2.4L	87-95	EJ-MI23A								8 7/8" - 225mm	23D - 23.0 x 26.0
L4 2.6L	83-85	EJ-MI23B								8 7/8" - 225mm	23D - 23.0 x 26.0
L4 2.6L	87-90	EJ-MI23A								8 7/8" - 225mm	23D - 23.0 x 26.0
<b>MINI COOPER NUEVAS APLICACIONES (*)</b>											
Mini Cooper											
*L4 1.6 Lts., 113-114 HP	03-06	EJ-MC20A									
<b>NISSAN - AUTOMÓVIL NUEVAS APLICACIONES (*)</b>											
<b>200 SX</b>											
L4 1.6L	95-98	EJ-N19A								7 1/2" - 191mm	18D - 18.0 x 20.7
<b>240 SX</b>											
L4 2.4L 16V, 5 Vel.	91-94	EJ-N23B								8.875 - 225mm	24D - 23.0 x 25.6
L4 2.4L DOHC, 16V, 5 Vel.	96-98	EJ-N23B								8.875 - 225mm	24D - 23.0 x 25.6
<b>300 ZX</b>											
V6 3.0L Turbo	84-86	EJ-N24H								9 1/2" - 241mm	24D - 23.0 x 25.6
<b>Almera</b>											
L4 1.8L DOHC, 16 V, 5 Vel.	01-05	EJ-N22C								8 1/2" - 216mm	18D - 18.1 x 20.5
<b>Aprio</b>											
L4 1.6L 16V (K4M) 5 Vel.	02-10	EJ-N20D								7 7/8" - 200mm	26D - 23.0 x 25.6
<b>Altima</b>											
L4 2.4L DOHC, 16V, 5 Vel.	93-97	EJ-N23A								8 7/8" - 225mm	24D - 23.0 x 25.6
L4 2.5L 5 Vel.	02-06	EJ-N24I									
<b>Axxess</b>											
L4 2.4L DOHC, 16V, 5 Vel.	90	EJ-N23A								8 7/8" - 225mm	24D - 23.0 x 25.6
<b>Datsun 310</b>											
L4 1.5L	82	EJ-N18A								7 1/8" - 181mm	18D - 18 x 20.7
<b>Datsun 810</b>											
L4 2.4L	77-84	EJ-N20B								7 7/8" - 200mm	24D - 23.0 x 25.6
L4 2.4L	82	EJ-N18A								7 1/8" - 181mm	18D - 18 x 20.7
<b>Datsun 1600</b>											
L4 1.6L 4 Vel.	77-84	EJ-N20A								7 7/8" - 200mm	24D - 23.0 x 25.6
<b>Datsun 1800</b>											
L4 1.8L 4 Vel.	77-84	EJ-N20A								7 7/8" - 200mm	24D - 23.0 x 25.6
<b>Datsun 160J</b>											
L4 1.6L 4 Vel.	77-84	EJ-N20A								7 7/8" - 200mm	24D - 23.0 x 25.6
<b>Datsun 180J</b>											
L4 1.8L 4 Vel.	77-84	EJ-N20A								7 7/8" - 200mm	24D - 23.0 x 25.6
<b>Hikari Coupé</b>											
L4 1.6L 4 Vel.	87-92	EJ-N18A								7 1/8" - 181mm	18D - 18 x 20.7
<b>Micra</b>											
L4 1.4L 5 Vel. (Sin CSC)	05->>	EJ-N19B2								7 1/2" - 190mm	26D - 20.0 x 21.6



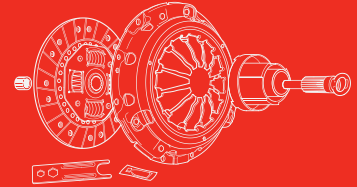

APLICACIÓN	01	NÚMERO DE PARTE	MODULAR	AUTO-AJUSTABLE	VOLANTE	BI-MASA	COLL. HID. INCLUIDO	NÚMERO DE IMAGEN COLL. HID.	PÁGINA DE IMAGEN COLL. HID.	DIÁMETRO	ESTRIADO
<b>NISSAN - PICK-UP / CAMIONETA</b>											
<b>Pick-Up</b>											
L4 2.0L	83-92	EJ-N24H								9 1/2" - 241mm	24D - 23.0 x 25.6
L4 2.4L	82-96	EJ-N24H								9 1/2" - 241mm	24D - 23.0 x 25.6
L4 2.4L 12V,(KA24E) 5 Vel.	97-08	EJ-N24B								9 1/2" - 241mm	24D - 23.0 x 25.6
V6 3.0L	85-96	EJ-N25A								9 13/16" - 250mm	24D - 23.0 x 25.6
<b>Pick-Up Doble Cabina (D21)</b>											
L4 2.4L	85-97	EJ-N24H								9 1/2" - 241mm	24D - 23.0 x 25.6
L4 2.4L 12V, 5 Vel.	91-93	EJ-N24A								9 1/2" - 241mm	24D - 23.0 x 25.6
L4 2.4L 12V, 5 Vel.	94-96	EJ-N24A								9 1/2" - 241mm	24D - 23.0 x 25.6
L4 2.4L 12V,(KA24E) 5 Vel.	91-96	EJ-N24B								9 1/2" - 241mm	24D - 23.0 x 25.6
L4 2.4L 12V,(KA24E) 5 Vel.	97-08	EJ-N24B								9 1/2" - 241mm	24D - 23.0 x 25.6
<b>Urvan</b>											
L4 2.4L 5 Vel.	00->	EJ-N24F								9 13/16" - 250mm	24D - 23.0 x 25.6
<b>Xterra</b>											
L4 2.4L 12V,(KA24E) 5 Vel.	99-04	EJ-N24B								9 1/2" - 241mm	24D - 23.0 x 25.6
<b>PEUGEOT - AUTOMÓVIL</b>											
<b>206 XR/XS</b>											
L4 1.4L 5 Vel.	99-06	EJ-P18A								7 1/16" - 180mm	18D - 18.2 x 20.8
L4 1.6 5 Vel.	99-00	EJ-P20B								7 7/8" - 200mm	18D - 18.2 x 20.8
L4 1.6 5 Vel.	01-07	EJ-P20D								7 7/8" - 200mm	18D - 18.3 x 20.8
<b>306</b>											
L4 1.8 5 Vel.	93-03	EJ-P20A								7 7/8" - 200mm	18D - 18.3 x 20.8
<b>306 SR</b>											
L4 1.6 5 Vel.	97-02	EJ-P20B								7 7/8" - 200mm	18D - 18.2 x 20.8
<b>307</b>											
L4 2.0 138HP	02-10	EJ-P23A								9 1/16" - 230mm	18D - 18.3 x 20.8
<b>405 STI, SRI</b>											
L4 2.0 5 Vel.	97-00	EJ-P22B								8 1/2" - 217mm	18D - 18.3 x 20.8
<b>PEUGEOT - FURGONETA</b>											
<b>Partner</b>											
L4 1.6L 5 Vel.	03-10	EJ-P20C								7 7/8" - 200mm	18D - 18.3 x 20.8
<b>Grand Raid</b>											
L4 1.6L 5 Vel.	07-10	EJ-P20C								7 7/8" - 200mm	18D - 18.3 x 20.8
<b>PONTIAC - AUTOMÓVIL</b>											
<b>6000</b>											
L4 2.5L	84	EJ-GM23C								9 3/16" - 233mm	14D - 21.5 x 25.1
L4 2.5L	87-88	EJ-GM23A								9 1/4" - 234mm	14D - 21.5 x 25.1
V6 2.5L	86-88	EJ-GM23A								9 1/4" - 234mm	14D - 21.5 x 25.1
<b>Boneville</b>											
V6 2.5L	88-89	EJ-GM23A								9 1/4" - 234mm	14D - 21.5 x 25.1
<b>Catalina</b>											
V6 2.5L	88-89	EJ-GM23A								9 1/4" - 234mm	14D - 21.5 x 25.1
<b>G3</b>											
L4 1.6L DOHC	08->	EJ-GM22F								8 7/16" - 211mm	24D - 18.3 x 20.7



**Anticongelante**  
**Refrigerante**

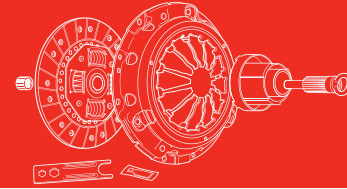

APLICACIÓN



NÚMERO DE PARTE

MODULAR

AUTO-AJUSTABLE

VOLANTE

BI-MASA

COLL. HID. INCLUIDO

NÚMERO DE IMAGEN

COLL. HID.

PÁGINA DE IMAGEN

COLL. HID.

DIÁMETRO

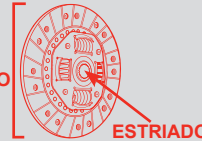

ESTRIADO

### PONTIAC - AUTOMÓVIL

Continuación

#### G4

L4 2.2L DOHC	05-06	EJ-GM24B				X			9 7/16" - 240mm	14D - 22 x 24.1
--------------	-------	----------	--	--	--	---	--	--	-----------------	-----------------

#### Grand Prix

V6 2.5L	88-89	EJ-GM23A							9 1/4" - 234mm	14D - 21.5 x 25.1
---------	-------	----------	--	--	--	--	--	--	----------------	-------------------

#### GrandVille

V6 2.5L	88-89	EJ-GM23A							9 1/4" - 234mm	14D - 21.5 x 25.1
---------	-------	----------	--	--	--	--	--	--	----------------	-------------------

#### Fiero

L4 2.5L	84	EJ-GM23C							9 3/16" - 233mm	14D - 21.5 x 25.1
---------	----	----------	--	--	--	--	--	--	-----------------	-------------------

#### Fiero

V6 2.8L 4 Vel.	85-87	EJ-GM23C							9 3/16" - 233mm	14D - 21.5 x 25.1
----------------	-------	----------	--	--	--	--	--	--	-----------------	-------------------

V6 2.8L 5 Vel.	85-88	EJ-GM23A							9 1/4" - 234mm	14D - 21.5 x 25.1
----------------	-------	----------	--	--	--	--	--	--	----------------	-------------------

#### Firebird

L4 2.5L	83-86	EJ-GM23J							9 1/16" - 230mm	14D - 21.5 x 25.1
---------	-------	----------	--	--	--	--	--	--	-----------------	-------------------

V6 2.8L	83	EJ-GM25B							9 1/16" - 231mm	14D - 1 1/8"
---------	----	----------	--	--	--	--	--	--	-----------------	--------------

V8 5.7L (350")	94-97	EJ-GM28B							11" - 280mm	26D - 26.5 x 29.5
----------------	-------	----------	--	--	--	--	--	--	-------------	-------------------

V8 5.7L (350") MPFI, 6 Vel. (Incluye Volante)	97-99	EJ-GM30O	X						11 11/16" - 297mm	26D - 26.65x30.2
---	-------	----------	---	--	--	--	--	--	-------------------	------------------

#### Grand Am

L4 2.3L	89-91	EJ-GM23A							9 1/4" - 234mm	14D - 21.5 x 25.1
---------	-------	----------	--	--	--	--	--	--	----------------	-------------------

L4 2.3L	92	EJ-GM23A							9 1/4" - 234mm	14D - 21.5 x 25.1
---------	----	----------	--	--	--	--	--	--	----------------	-------------------

L4 2.5L	89-91	EJ-GM22E							8 1/2" - 216mm	14D - 21.5 x 25.1
---------	-------	----------	--	--	--	--	--	--	----------------	-------------------

#### J2000

L4 1.8L 5 Vel.	86	EJ-GM23C							9 3/16" - 233mm	14D - 21.5 x 25.1
----------------	----	----------	--	--	--	--	--	--	-----------------	-------------------

L4 1.8L 5 Vel.	87-91	EJ-GM21B							8 7/16" - 214mm	14D - 21.5 x 25.1
----------------	-------	----------	--	--	--	--	--	--	-----------------	-------------------

L4 2.0L	83-86	EJ-GM23C							9 3/16" - 233mm	14D - 21.5 x 25.1
---------	-------	----------	--	--	--	--	--	--	-----------------	-------------------

L4 2.0L	87-91	EJ-GM21B							8 7/16" - 214mm	14D - 21.5 x 25.1
---------	-------	----------	--	--	--	--	--	--	-----------------	-------------------

L4 2.2L 5 Vel.	02-05	EJ-GM23M			X	EC-GM23M	49		8 7/8" - 225mm	14D - 21.5 x 25.1
----------------	-------	----------	--	--	---	----------	----	--	----------------	-------------------

L4 2.3L (370")	95	EJ-GM23D			X	EC-GM22B	49		8 7/8" - 225mm	14D - 21.5 x 25.1
----------------	----	----------	--	--	---	----------	----	--	----------------	-------------------

L4 2.4L	96-99	EJ-GM23D			X	EC-GM22B	49		8 7/8" - 225mm	14D - 21.5 x 25.1
---------	-------	----------	--	--	---	----------	----	--	----------------	-------------------

V6 3.1L (188")	91-92	EJ-GM23A							9 1/4" - 234mm	14D - 21.5 x 25.1
----------------	-------	----------	--	--	--	--	--	--	----------------	-------------------

#### Matiz

L4 1.0L 5 Vel.	03-11	EJ-GM19D							7 5/16" - 185mm	18D - 17.0 x 19.1
----------------	-------	----------	--	--	--	--	--	--	-----------------	-------------------

#### Phoenix

L4 2.5L	80-84	EJ-GM23C							9 3/16" - 233mm	14D - 21.5 x 25.1
---------	-------	----------	--	--	--	--	--	--	-----------------	-------------------

V6 2.8L	80-84	EJ-GM23C							9 3/16" - 233mm	14D - 21.5 x 25.1
---------	-------	----------	--	--	--	--	--	--	-----------------	-------------------

#### Sunbird

L4 1.8L 5 Vel.	86	EJ-GM23C							9 3/16" - 233mm	14D - 21.5 x 25.1
----------------	----	----------	--	--	--	--	--	--	-----------------	-------------------

L4 1.8L 5 Vel.	87-91	EJ-GM21B							8 7/16" - 214mm	14D - 21.5 x 25.1
----------------	-------	----------	--	--	--	--	--	--	-----------------	-------------------

L4 2.0L	83-86	EJ-GM23C							9 3/16" - 233mm	14D - 21.5 x 25.1
---------	-------	----------	--	--	--	--	--	--	-----------------	-------------------

L4 2.2L 5 Vel.	02-05	EJ-GM23M			X	EC-GM23M	49		8 7/8" - 225mm	14D - 21.5 x 25.1
----------------	-------	----------	--	--	---	----------	----	--	----------------	-------------------

L4 2.3L	95	EJ-GM23D			X	EC-GM22B	49		8 7/8" - 225mm	14D - 21.5 x 25.1
---------	----	----------	--	--	---	----------	----	--	----------------	-------------------

L4 2.4L	96-99	EJ-GM23D			X	EC-GM22B	49		8 7/8" - 225mm	14D - 21.5 x 25.1
---------	-------	----------	--	--	---	----------	----	--	----------------	-------------------

V6 3.1L	91-92	EJ-GM23A							9 1/4" - 234mm	14D - 21.5 x 25.1
---------	-------	----------	--	--	--	--	--	--	----------------	-------------------

#### Sunfire

L4 1.8L 5 Vel.	86	EJ-GM23C							9 3/16" - 233mm	14D - 21.5 x 25.1
----------------	----	----------	--	--	--	--	--	--	-----------------	-------------------



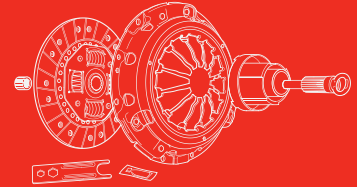

APLICACIÓN	01	NÚMERO DE PARTE	MODULAR	AUTO-AJUSTABLE	VOLANTE BI-MASA	COLL. HID. INCLUIDO	NÚMERO DE IMAGEN COLL. HID.	PÁGINA DE IMAGEN COLL. HID.	DIÁMETRO	ESTRIADO
<b>PONTIAC - AUTOMÓVIL</b>										
<b>Sunfire</b>										
L4 1.8L 5 Vel.	87-91	EJ-GM21B							8 7/16" - 214mm	14D - 21.5 x 25.1
L4 2.0L	83-86	EJ-GM23C							9 3/16" - 233mm	14D - 21.5 x 25.1
L4 2.2L 5 Vel.	96-00	EJ-GM22B			X		EC-GM22B	49	8 1/2" - 216mm	14D - 21.5 x 25.1
L4 2.2L 5 Vel.	02-05	EJ-GM23M			X		EC-GM23M	49	8 7/8" - 225mm	14D - 21.5 x 25.1
L4 2.3L	95	EJ-GM23D			X		EC-GM22B	49	8 7/8" - 225mm	14D - 21.5 x 25.1
L4 2.4L	96-99	EJ-GM23D			X		EC-GM22B	49	8 7/8" - 225mm	14D - 21.5 x 25.1
L4 2.4L	01	EJ-GM23L			X		EC-GM23M	49	8 7/8" - 225mm	14D - 22 x 25
V6 3.1L	91-92	EJ-GM23A							9 1/4" - 234mm	14D - 21.5 x 25.1
<b>Trans Am</b>										
L4 2.5L	83-86	EJ-GM23J							9 1/16" - 230mm	14D - 21.5 x 25.1
V6 2.8L	83	EJ-GM25B							9 1/16" - 231mm	14D - 1 1/8"
V8 5.7L (350")	94-97	EJ-GM28B							11" - 280mm	26D - 26.5 x 29.5
<b>Z-28</b>										
L4 2.5L 5 Vel.	83-86	EJ-GM23J							9 1/16" - 230mm	14D - 21.5 x 25.1
V6 2.8L	83-84	EJ-GM25B							9 1/16" - 231mm	14D - 1 1/8"
V6 2.8L	85-89	EJ-GM23J							9 1/16" - 230mm	14D - 21.5 x 25.1
V6 3.1L	90-92	EJ-GM23J							9 1/16" - 230mm	14D - 21.5 x 25.1
V8 5.7L (350")	96-97	EJ-GM28B							11" - 280mm	26D - 26.5 x 29.5
<b>RENAULT - AUTOMÓVIL</b>										
<b>Clío</b>										
L4 1.6L 16V (K4M) 5 Vel.	02-10	EJ-N20D							7 7/8" - 200mm	26D - 23.0 x 25.6
<b>Clío Sport</b>										
L4 2.0L 16V 5 Vel.	02-05	EJ-R22B							8 11/16" - 220mm	26D - 20.6x21.3
<b>Megane</b>										
L4 2.0L DOHC, 16V, 5 Vel.	01-04	EJ-R22B							8 11/16" - 220mm	26D - 20.6x21.3
<b>Megane II</b>										
L4 2.0L DOHC, 16V, 6 Vel.	04-10	EJ-R24B							9 3/8" - 239mm	24D - 21.2X23.8
<b>Sandero / Steepway</b>										
L4 1.6L 16V (K4M) 5 Vel.	09->	EJ-N20D							7 7/8" - 200mm	26D - 23.0 x 25.6
<b>Scenic</b>										
L4 2.0L DOHC, 16V, 5 Vel.	02-04	EJ-R22B							8 11/16" - 220mm	26D - 20.6x21.3
<b>RENAULT - FURGONETA</b>										
<b>Kangoo</b>										
L4 1.6L 16V (K4M) 5 Vel.	02->	EJ-N20D							7 7/8" - 200mm	26D - 23.0 x 25.6
<b>SEAT - AUTOMÓVIL</b>										
<b>Altea</b>										
L5 2.0L 150HP, DOHC	08->	EJ-VW23G	X	X	X				9" - 228mm	28D
<b>Cordoba</b>										
L4 1.6L 8V, 5 Vel.	01-04	EJ-VW21B							8 1/4" - 210mm	28D - 20.3 x 22.1
L4 2.0L	03-09	EJ-SE22A							8 11/16" - 220mm	28D - 18.3 x 20.7
<b>Ibiza</b>										
L4 1.6L 8V, 5 Vel.	01-04	EJ-VW21B							8 1/4" - 210mm	28D - 20.3 x 22.1
L4 2.0L	03-09	EJ-SE22A							8 11/16" - 220mm	28D - 18.3 x 20.7



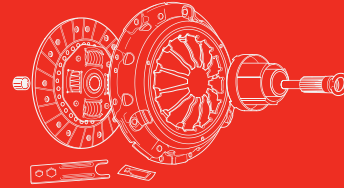

APLICACIÓN	01	NÚMERO DE PARTE	MODULAR	AUTO-AJUSTABLE	VOLANTE BILMASA	COLL. HID. INCLUIDO	NÚMERO DE IMAGEN COLL. HID.	PÁGINA DE IMAGEN COLL. HID.	DIÁMETRO	ESTRIADO
<b>SEAT - AUTOMÓVIL</b>										
Continuación										
<b>Ibiza FR/Cupra</b>										
L4 1.8T 150HP-180HP	04-05	EJ-VW22E	X		X				8 11/16" - 220mm	28D
L4 1.8L 150HP-180HP, 5 Vel., Versión Volante Sólido (Incluye Volante Sólido)	99-05	EJ-VW22ES							8 11/16" - 220mm	28D - 19.75x22
<b>Leon</b>										
L4 1.8L DOHC, 5 Vel.	01-06	EJ-VW22A							8 1/2" - 216mm	28D - 20.3 x 22.1
L4 2.0L 150HP, DOHC, 5 Vel.	01-08	EJ-VW23G	X	X	X				9" - 228mm	28D
<b>Toledo</b>										
L4 1.8L DOHC, 5 Vel.	01-06	EJ-VW22A							8 1/2" - 216mm	28D - 20.3 x 22.1
L4 2.0L 150HP, DOHC, 5 Vel.	01-08	EJ-VW23G	X	X	X				9" - 228mm	28D
<b>SUZUKI NUEVAS APLICACIONES (*)</b>										
<b>Aerio</b>										
*L4, 2.3 L 5 Vel.	06-07	EJ-SU22A								
<b>Sidekick</b>										
L4 1.6L	89-95	EJ-GE20A							7 7/8" - 200mm	20D - 20.0 x 22.5
<b>SX-4</b>										
*L4, 2.0 L 143 HP, 5 Vel.	08-10	EJ-SU22B								
<b>Vitara</b>										
L4 1.6L	89-91	EJ-GE20A							7 7/8" - 200mm	20D - 20.0 x 22.5
<b>TOYOTA - AUTOMÓVIL NUEVAS APLICACIONES (*)</b>										
<b>Celica</b>										
L4 2.4L GT,ST (22R)	81	EJ-TY23E							8 7/8" - 225mm	21D - 25 x 29.5
L4 2.4L GT,GTS (22REC)	83-85	EJ-TY23E							8 7/8" - 225mm	21D - 25 x 29.5
<b>Corolla</b>										
L4 1.6L	95-95	EJ-TY22E							8 7/16" - 215mm	21D - 21.2 x 24.7
<b>Corolla CE, LE, GTS</b>										
L4 1.8L	92-97	EJ-TY22E							8 7/16" - 215mm	21D - 21.2 x 24.7
L4 1.8L DOHC	02->>	EJ-TY22E							8 7/16" - 215mm	21D - 21.2 x 24.7
<b>Corona</b>										
L4 2.0L	71-77	EJ-TY23C							8 7/8" - 225mm	21D - 25.5 x 28.9
L4 2.2L	74-77	EJ-TY23C							8 7/8" - 225mm	21D - 25.5 x 28.9
<b>Crown</b>										
L4 2.4L Turbo (22R 22RE)	88-92	EJ-TY23A							8 7/8" - 225mm	21D - 25.5 x 28.9
<b>Matrix XR</b>										
L4 1.8L DOHC, WTi, 5 Vel.	03-06	EJ-TY22E							8 7/16" - 215mm	21D - 21.2 x 24.7
<b>MR2 Spyder</b>										
L4 1.8L	02-05	EJ-TY24F							9 3/8" - 238mm	21D - 26 x 29.8
<b>Supra</b>										
L6 2.8L	81	EJ-TY23E							8 7/8" - 225mm	21D - 25 x 29.5
<b>Tercel</b>										
L4 1.5L Motor 3E	88-90	EJ-TY19B							7 1/2" - 190mm	21D - 21.2 x 23.8
<b>Yaris</b>										
L4 1.3L	04-05	EJ-TY20B							7 7/8" - 200mm	21D -
L4 1.5L	06-09	EJ-TY20B							7 7/8" - 200mm	21D -



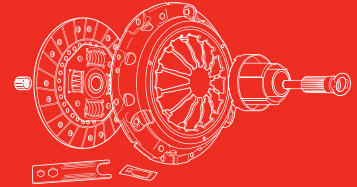

APLICACIÓN	01	NÚMERO DE PARTE	MODULAR	AUTO-AJUSTABLE	VOLANTE BI-MASA	COLL. HID. INCLUIDO	NÚMERO DE IMAGEN COLL. HID.	PÁGINA DE IMAGEN COLL. HID.	DIÁMETRO	ESTRIADO
<b>TOYOTA - AUTOMÓVIL NUEVAS APLICACIONES (*)</b>										
<b>Yaris</b>										
*L4 1.5L 5 Vel.	06->>	EJ-TY21C								
<b>TOYOTA - PICK-UP / SUV / CAMIONETA</b>										
<b>4 Runner</b>										
4L 2.2L (22R)	80-85	EJ-TY23B							8 7/8" - 225mm	21D - 25.5 x 28.9
4L 2.4L (22R 22RE)	85-92	EJ-TY23A							8 7/8" - 225mm	21D - 25.5 x 28.9
4L 2.4L (22RE)	93-97	EJ-TY24E							9 1/4" - 235mm	21D - 25.5 x 28.9
4L 2.4L (22R) Turbo	87-88	EJ-TY24E							9 1/4" - 235mm	21D - 25.5 x 28.9
4L 2.4L Diesel (22R) Turbo	80-85	EJ-TY23B							8 7/8" - 225mm	21D - 25.5 x 28.9
V6 3.0L 3VZ	90	EJ-TY24A							9 1/4" - 235mm	21D - 25.5 x 28.9
<b>Hiace</b>										
L4 2.7L DOHC.	06->>	EJ-TY25A							9 13/16" - 250mm	21D - 25.5 x 28.9
<b>Hi-Lux</b>										
L4 2.0L	94-95	EJ-TY23B							8 7/8" - 225mm	21D - 25.5 x 28.9
L4 2.4L	83-89	EJ-TY23B							8 7/8" - 225mm	21D - 25.5 x 28.9
L4 2.4L	91-94	EJ-TY23A							8 7/8" - 225mm	21D - 25.5 x 28.9
L4 2.7L DOHC.	03-05	EJ-TY25A							9 13/16" - 250mm	21D - 25.5 x 28.9
V6 3.0L (3VZ)	90	EJ-TY24A							9 1/4" - 235mm	21D - 25.5 x 28.9
<b>Pick-Up</b>										
L4 2.0L	72-74	EJ-TY23C							8 7/8" - 225mm	21D - 25.5 x 28.9
L4 2.2L	74-80	EJ-TY23C							8 7/8" - 225mm	21D - 25.5 x 28.9
L4 2.4L	93-96	EJ-TY23H							8 7/8" - 225mm	21D - 25.5 x 28.9
L4 2.4L Turbo	85-87	EJ-TY24B							9 7/16" - 240mm	21D - 25.5 x 28.9
L4 2.4L 22R	87-88	EJ-TY24C							9 1/4" - 235mm	21D - 25.5 x 28.9
L4 2.4L 22RE 4X4	93-96	EJ-TY24C							9 1/4" - 235mm	21D - 25.5 x 28.9
<b>VAM</b>										
<b>Jeep Willis CJ5, CJ7, CJ100, CJ300</b>										
L6 4.2L	71-86	EJ-VA26A							10 3/8" - 263mm	10D - 1 1/16"
L6 4.2L	71-86	EJ-VA26A							10 3/8" - 263mm	10D - 1 1/16"
<b>VOLKSWAGEN - AUTOMÓVIL</b>										
<b>Atlantic</b>										
L4 1.6L 4 Vel.	77-81	EJ-VW19A							7 1/2" - 191mm	24D - 18.3 x 20.7
L4 1.7L 4 Vel.	77-83	EJ-VW19A							7 1/2" - 191mm	24D - 18.3 x 20.7
L4 1.8L 5 Vel.	84-87	EJ-VW21A							8 1/4" - 210mm	24D - 18.3 x 20.7
<b>Bora</b>										
L5 2.5L	06-10	EJ-VW23G	X	X	X				9" - 228mm	28D
<b>Brasilia</b>										
L4 1.6L (Disco sin resortes)	74-82	EJ-VW20A							7 7/8" - 200mm	24D - 18.3 x 20.7
L4 1.6L (Disco con resortes)	74-82	EJ-VW20B							7 7/8" - 200mm	24D - 18.3 x 20.7
<b>Cabriolet</b>										
L4 1.8L	84-92	EJ-VW21A							8 1/4" - 210mm	24D - 18.3 x 20.7
<b>Caribe</b>										
L4 1.5L Diesel	78-81	EJ-VW20D							7 7/8" - 200mm	24D - 18.3 x 20.7



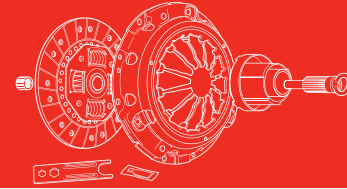

APLICACIÓN



NÚMERO DE PARTE

MODULAR

AUTO-AJUSTABLE

VOLANTE

BI-MASA

COLL. HID. INCLUIDO

NÚMERO DE IMAGEN COLL. HID.

PÁGINA DE IMAGEN COLL. HID.

DIÁMETRO

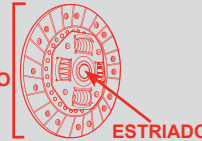

ESTRIADO

### VOLKSWAGEN - AUTOMÓVIL

Continuación

Caribe										Continuación	
L4 1.6L Diesel	78-81	EJ-VW20D								7 7/8" - 200mm	24D - 18.3 x 20.7
L4 1.6L 4 Vel.	77-81	EJ-VW19A								7 1/2" - 191mm	24D - 18.3 x 20.7
L4 1.7L 4 Vel.	84-85	EJ-VW20C								7 7/8" - 200mm	24D - 18.3 x 20.7
L4 1.8L 5 Vel.	84-87	EJ-VW21A								8 1/4" - 210mm	24D - 18.3 x 20.7
<b>Corsar CD / Variant</b>											
L4 1.8L 5 Vel.	83-88	EJ-VW21C								8 1/4" - 210mm	24D - 18.3 x 20.7
<b>Crossfox</b>											
L4 1.6L 5 Vel.	06-10	EJ-VW20F								7 7/8" - 200mm	28D - 20.3 x 22.1
<b>Derby</b>											
L4 1.8L 5 Vel.	94-05	EJ-VW21B2								8 1/4" - 210mm	24D - 18.3 x 20.7
L4 2.0L 5 Vel.	01-04	EJ-VW22A								8 1/2" - 216mm	28D - 20.3 x 22.1
L4 2.0L 5 Vel.	01-04	EJ-VW21B								8 1/4" - 210mm	28D - 20.3 x 22.1
<b>Fox</b>											
L4 1.8L	87-93	EJ-VW21C								8 1/4" - 210mm	24D - 18.3 x 20.7
<b>Golf (A2) CL / GL / GTI</b>											
L4 1.8L 4 y 5 Vel.	85-92	EJ-VW21A								8 1/4" - 210mm	24D - 18.3 x 20.7
<b>Golf (A3) Cabriolet / CL / GL / GTI / Mi</b>											
L4 1.8L 5 Vel.	93	EJ-VW21A								8 1/4" - 210mm	24D - 18.3 x 20.7
L4 1.8L 5 Vel.	94-99	EJ-VW21B2								8 1/4" - 210mm	24D - 18.3 x 20.7
L4 2.0L 5 Vel.	93	EJ-VW21D								8 1/4" - 210mm	28D - 20.3 x 22.1
L4 2.0L 5 Vel.	94-99	EJ-VW21B								8 1/4" - 210mm	28D - 20.3 x 22.1
<b>Golf (A3) VR6</b>											
V6 2.8L 5 Vel.	98-99	EJ-VW23B								9" - 228mm	28D - 20.3 x 22.1
<b>Golf (A4)</b>											
L4 2.0L 5 Vel.	99->>	EJ-VW22A								8 1/2" - 216mm	28D - 20.3 x 22.1
<b>Golf (A4) Cabrio</b>											
L4 2.0L 5 Vel.	99-03	EJ-VW22A								8 1/2" - 216mm	28D - 20.3 x 22.1
<b>Golf (A4) Turbo</b>											
L4 1.8L 150HP, 5 Vel.	99->>	EJ-VW22E	X		X					8 11/16" - 220mm	28D
L4 1.8L 150HP, 5 Vel., Versión Volante Sólido (Incluye Volante Sólido)	99->>	EJ-VW22ES								8 11/16" - 220mm	28D - 19.75x22
<b>Golf (A4) VR6</b>											
V6 2.8L 5 Vel.	95-99	EJ-VW23B								9" - 228mm	28D - 20.3 x 22.1
V6 2.8L 5 Vel. DOHC	99-04	EJ-VW24A	X		X	X				9 3/8" - 238mm	23D
<b>Golf (A4) R32</b>											
V6 3.2L 5 Vel.	02-04	EJ-VW23B								9" - 228mm	28D - 20.3 x 22.1
<b>Jetta (A2) C / GL</b>											
L4 1.8L 5 Vel.	87-92	EJ-VW21A								8 1/4" - 210mm	24D - 18.3 x 20.7
<b>Jetta (A3) C / CL / Europa / GL / GLS</b>											
L4 1.8L 5 Vel.	93	EJ-VW21A								8 1/4" - 210mm	24D - 18.3 x 20.7
L4 1.8L 5 Vel.	97-98	EJ-VW21B2								8 1/4" - 210mm	24D - 18.3 x 20.7
L4 2.0L 5 Vel.	93-94	EJ-VW21D								8 1/4" - 210mm	28D - 20.3 x 22.1
L4 2.0L 5 Vel.	94-99	EJ-VW21B								8 1/4" - 210mm	28D - 20.3 x 22.1



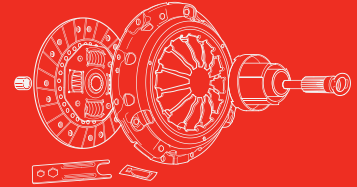

APLICACIÓN	01	NÚMERO DE PARTE	MODULAR	AUTO-AJUSTABLE	VOLANTE BI-MASA	COLL. HID. INCLUIDO	NÚMERO DE IMAGEN COLL. HID.	PÁGINA DE IMAGEN COLL. HID.	DIÁMETRO	ESTRIADO
<b>VOLKSWAGEN - AUTOMÓVIL</b>										
<b>Continuación</b>										
<b>Jetta (A3) C / GL TDI</b>										
L4 1.9L Diesel	93-97	EJ-VW21B2							8 1/4" - 210mm	24D - 18.3 x 20.7
<b>Jetta (A3) Carat / GL / GLS / GLX / VR6</b>										
L4 2.0L 5 Vel.	94-99	EJ-VW21B							8 1/4" - 210mm	28D - 20.3 x 22.1
V6 2.8L 5 Vel.	94-99	EJ-VW23B							9" - 228mm	28D - 20.3 x 22.1
<b>Jetta (A4)</b>										
L4 2.0L 5 Vel.	99-10	EJ-VW22A							8 1/2" - 216mm	28D - 20.3 x 22.1
<b>Jetta (A4) Turbo</b>										
L4 1.8T 150HP-180HP	99-05	EJ-VW22E	X	X					8 11/16" - 220mm	28D
L4 1.8L 150HP-180HP, 5 Vel., Versión Volante Sólido (Incluye Volante Sólido)	99-05	EJ-VW22ES							8 11/16" - 220mm	28D - 19.75x22
<b>Jetta (A4) VR6</b>										
V6 2.8L 5 Vel.	95-99	EJ-VW23B							9" - 228mm	28D - 20.3 x 22.1
V6 2.8L 5 Vel.	99-04	EJ-VW24A	X	X	X				9 3/8" - 238mm	23D
<b>Jetta TDI</b>										
L4 1.9L OHC 5 Vel.	06-10	EJ-VW22D	X	X					8 11/16" - 220mm	28D
<b>Lupo</b>										
L4 1.6L 5 Vel.	04->>	EJ-VW20F							7 7/8" - 200mm	28D - 20.3 x 22.1
<b>New Beetle</b>										
L4 2.0L 5 Vel.	98-05	EJ-VW22A							8 1/2" - 216mm	28D - 20.3 x 22.1
L5 2.5L	07-10	EJ-VW23G	X	X	X				9" - 228mm	28D
<b>New Beetle Turbo</b>										
L4 1.8T 150HP-180HP	99-03	EJ-VW22E	X	X					8 11/16" - 220mm	28D
L4 1.8L 150HP-180HP, 5 Vel., Versión Volante Sólido (Incluye Volante Sólido)	99-05	EJ-VW22ES							8 11/16" - 220mm	28D - 19.75x22
<b>New Beetle Super</b>										
V6 3.2L	02-04	EJ-VW24A	X	X	X				9 3/8" - 238mm	23D
<b>Passat VR6 / Variant</b>										
V6 2.8L 5 Vel.	97-98	EJ-VW23B							9" - 228mm	28D - 20.3 x 22.1
V6 2.8L 5 Vel.	97-98	EJ-VW23B							9" - 228mm	28D - 20.3 x 22.1
<b>Pointer City / GTI</b>										
L4 1.8L 5 Vel.	97-05	EJ-VW21C							8 1/4" - 210mm	24D - 18.3 x 20.7
L4 2.0L 5 Vel.	00-03	EJ-VW21C							8 1/4" - 210mm	24D - 18.3 x 20.7
<b>Pointer Pick-Up</b>										
L4 1.8L 5 Vel.	98-05	EJ-VW21C							8 1/4" - 210mm	24D - 18.3 x 20.7
<b>Pointer Wagon</b>										
L4 1.8L 5 Vel.	98-05	EJ-VW21C							8 1/4" - 210mm	24D - 18.3 x 20.7
<b>Polo</b>										
L4 1.6L 5 Vel.	03->>	EJ-VW20F							7 7/8" - 200mm	28D - 20.3 x 22.1
<b>Rabbit GTI</b>										
L4 1.8L 8V	82-90	EJ-VW21A							8 1/4" - 210mm	24D - 18.3 x 20.7
<b>Safari</b>										
L4 1.5 / 1.6L 4 Vel. (Disco sin resortes)	72-73	EJ-VW20A							7 7/8" - 200mm	24D - 18.3 x 20.7
L4 1.5 / 1.6L 4 Vel. (Disco con resortes)	72-73	EJ-VW20B							7 7/8" - 200mm	24D - 18.3 x 20.7



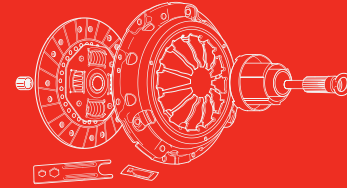

APLICACIÓN



NÚMERO DE PARTE

MODULAR

AUTO-AJUSTABLE

VOLANTE

BI-MASSA

COLL. HID. INCLUIDO

NÚMERO DE IMAGEN COLL. HID.

PÁGINA DE IMAGEN COLL. HID.

DIÁMETRO

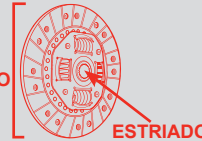

ESTRIADO

### VOLKSWAGEN - AUTOMÓVIL

Continuación

#### Scirocco

L4 1.8L 8V	83-89	EJ-VW21A							8 1/4" - 210mm	24D - 18.3 x 20.7
------------	-------	----------	--	--	--	--	--	--	----------------	-------------------

#### Sedán

L4 1.5 / 1.6L 4 Vel. (Disco sin resortes)	72-73	EJ-VW20A							7 7/8" - 200mm	24D - 18.3 x 20.7
L4 1.5 / 1.6L 4 Vel. (Disco con resortes)	74-03	EJ-VW20B							7 7/8" - 200mm	24D - 18.3 x 20.7
L4 1.5L OHV (Disco con resortes)	68-71	EJ-VW20B2							7 7/8" - 200mm	24D - 18.3 x 20.7

### VOLKSWAGEN - PICK UP / CAMIONETA

#### Caravan Wagon

L4 1.9L	83-92	EJ-VW23A							9" - 229mm	24D - 18.3 x 20.7
L4 2.1L (128")	83-92	EJ-VW23A							9" - 229mm	24D - 18.3 x 20.7
L4 2.2L	83-92	EJ-VW23A							9" - 229mm	24D - 18.3 x 20.7

#### Combi Caravelle

L4 1.6L 4 Vel. (Disco sin resortes)	74-87	EJ-VW20A							7 7/8" - 200mm	24D - 18.3 x 20.7
L4 1.6L 4 Vel. (Disco con resortes)	74-87	EJ-VW20B							7 7/8" - 200mm	24D - 18.3 x 20.7
L4 1.8L 4 Vel.	88-01	EJ-VW23A							9" - 229mm	24D - 18.3 x 20.7

#### Combi Panel

L4 1.5 / 1.6L 4 Vel. (Disco sin resortes)	74-87	EJ-VW20A							7 7/8" - 200mm	24D - 18.3 x 20.7
L4 1.5 / 1.6L 4 Vel. (Disco con resortes)	74-87	EJ-VW20B							7 7/8" - 200mm	24D - 18.3 x 20.7
L4 1.8L 4 Vel.	91-96	EJ-VW23A							9" - 229mm	24D - 18.3 x 20.7

#### Eurovan

L5, 2.4L	93-95	EJ-VW23B							9" - 228mm	28D - 20.3 x 22.1
L5, 2.4L Diesel	96	EJ-VW23B							9" - 228mm	28D - 20.3 x 22.1
L5, 2.5L	92-95	EJ-VW23B							9" - 228mm	28D - 20.3 x 22.1
L5, 2.5L 5 Vel.	00-04	EJ-VW23E							9" - 229mm	28D - 20.3 x 22.1

#### Pointer Pick-Up

L4 1.8L 5 Vel.	98-05	EJ-VW21C							8 1/4" - 210mm	24D - 18.3 x 20.7
----------------	-------	----------	--	--	--	--	--	--	----------------	-------------------

#### Sportvan

L4 1.6L 5 Vel.	06->>	EJ-VW20F							7 7/8" - 200mm	28D - 20.3 x 22.1
----------------	-------	----------	--	--	--	--	--	--	----------------	-------------------

#### Van

L4 1.8L 5 Vel.	03->>	EJ-VW22C							8 1/2" - 216mm	28D - 20.3 x 22.1
----------------	-------	----------	--	--	--	--	--	--	----------------	-------------------

#### Vanagon (II)

L4 1.9L	83-85	EJ-VW23A							9" - 229mm	24D - 18.3 x 20.7
L4 2.0L	80-83	EJ-VW23A							9" - 229mm	24D - 18.3 x 20.7
L4 2.1L (128")	86-91	EJ-VW23A							9" - 229mm	24D - 18.3 x 20.7
L4 2.2L	83-92	EJ-VW23A							9" - 229mm	24D - 18.3 x 20.7



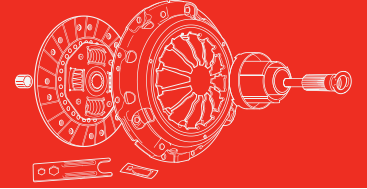

Número de Parte	Kits en los que aplica	Cuerpo de Poliamida	Cuerpo de aluminio	Conector Tech-Link	Incluye herramienta de desconexión	Producto <b>TECHnovation</b> <small>CONEXIÓN INNOVATIVA</small>	Imagen del Producto
EC-F19A	EJ-F18C EJ-F19A EJ-F22H		X				
EC-F23I	EC-F23I		X				
EC-F23J	EJ-F23J EJ-F24C		X				
EC-F23N3	EJ-F23N3		X			X	



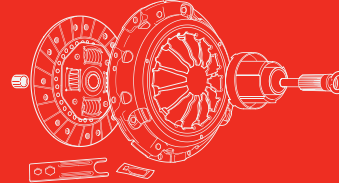

Número de Parte	Kits en los que aplica	Cuerpo de Poliamida	Cuerpo de aluminio	Conector Tech-Link	Incluye herramienta de desconexión	Producto <b>TECH:innovation</b>	Imagen del Producto
EC-F23P3	EJ-D31A3 EJ-F23P3 EJ-F25D3 EJ-F25K3 EJ-F29B3		X	X	X	X	
EC-F24B	EJ-F24B EJ-F24D		X				
EC-F29A3	EJ-F23D3 EJ-F23DE3 EJ-F23G3 EJ-F23Q3 EJ-F25E3 EJ-F29C3 EJ-F29CE3 EJ-F30B3		X	X	X	X	
EC-GM21F	EJ-GM20D EJ-GM21A EJ-GM21F	X					



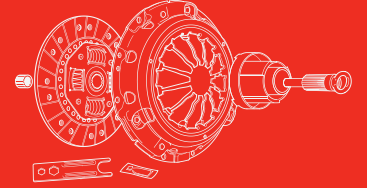

Número de Parte	Kits en los que aplica	Cuerpo de Poliamida	Cuerpo de aluminio	Conector Tech-Link	Incluye herramienta de desconexión	Producto <b>TECHnovation</b> <small>CONEXIÓN INDEPENDIENTE</small>	Imagen del Producto
EC-GM21F1	EJ-GM20D* EJ-GM21A* EJ-GM21F*		X				
*No está incluido en esos kits, pero sí es compatible con sus aplicaciones.							
EC-GM22B	EJ-GM22B		X	X	X	X	
EC-GM23B	EJ-GM23B		X	X	X	X	
EC-GM23M	EJ-GM21D EJ-GM23L EJ-GM23M		X			X	



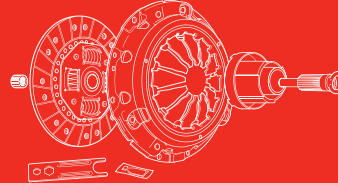

Número de Parte	Kits en los que aplica	Cuerpo de Poliamida	Cuerpo de aluminio	Conector Tech-Link	Incluye herramienta de desconexión	Producto <b>TECH:innovation</b> <small>EXCLUSIVO PARA TECNOLINK</small>	Imagen del Producto
EC-GM30H	EJ-GM30G3 EJ-GM30H EJ-GM30HE EJ-GM30I EJ-GM30K		X	X	X	X	
EC-GM31A3	EJ-GM23G3 EJ-GM28C3 EJ-GM30C3 EJ-GM30E3 EJ-GM30F3 EJ-GM30FE3 EJ-GM31A3		X	X	X	X	



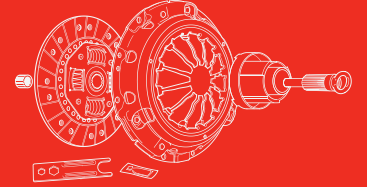

## LISTA DE EQUIVALENCIA DE NÚMERO DE PARTE

No. De parte	No. Ref 1	No. Ref 2
EJ-D18B	618 3016 00	K260033-01
EJ-D20C	620 2886 00	KF621-06
EJ-D21E	622 3034 00	
EJ-D21F	622 3052 00	
EJ-D22A	622 0694 00	K0050-01
EJ-D22C	622 2355 00	K70131-01
EJ-D22F	621 3031 00	K70304-01
EJ-D22G	622 0576 60	
EJ-D23A	623 0703 00	K0066-01
EJ-D23B	623 1500 00	K70297-01
EJ-D23D	623 2144 00	K70132-01
EJ-D23F	623 2752 00	
EJ-D23G		K70058-01
EJ-D23H	417 0032 10	K70058-01
EJ-D23I	623 2787 00	
EJ-D23J	623 1727 33	K0117-01
EJ-D23K	623 2143 00	
EJ-D23M	623 1577 33	K1914-03
EJ-D23N	623 2162 00	K0063-03
EJ-D23O	623 2788 00	
EJ-D23O	623 2789 00	
EJ-D23P	623 3061 00	K70340-01
EJ-D23R	623 2791 00	
EJ-D23T	623 3129 00	
EJ-D23U	623 3177 00	
EJ-D23V	623 3185 00	K70297-01
EJ-D23X	623 2885 00	
EJ-D24A	417 9033 20	K70344-01
EJ-D24D	624 3196 00	K633302-01
EJ-D24E	624 3217 00	
EJ-D26A	626 3005 33	
EJ-D26B	626 3007 33	K-1890-04
EJ-D26C	626 3012 00	
EJ-D26D	627 1580 33	
EJ-D26F	627 3006 00	
EJ-D26G	626 3023 00	
EJ-D27J	627 2792 00	
EJ-D28A	628 0719 00	KM1433-02
EJ-D28B	628 0718 00	KM5473-02
EJ-D28D	628 0721 00	
EJ-D28F	628 0867 00	K70082-01
EJ-D28F	628 0867 00	KM0087-02

No. De parte	No. Ref 1	No. Ref 2
EJ-D28H	628 1742 00	KM11064-01
EJ-D28L		K1877-06
EJ-D28P	628 0693 00	
EJ-D29A	630 3031 00	K70144-02
EJ-D30A	630 1743 00	KM10993-01
EJ-D30C	630 0848 00	KM 5473-02
EJ-D30E	630 3017 33	K70145-01
EJ-D30F	630 3016 33	K70145-01
EJ-D30H	630 3047 00	
EJ-GM23D	623 2151 33	K70163-01
EJ-GM23E	623 0705 00	KM136-01
EJ-GM23F	623 2141 00	KM136-02
EJ-GM23G	624 2806 00	KM136-04
EJ-GM23G3	624 2806 33	
EJ-GM23J	623 2790 00	
EJ-GM23K	623 3062 33	
EJ-GM23L	623 3091 33	K70258-01
EJ-GM23M	623 3181 33	K70330-01
EJ-GM23N	623 3128 33	K600527-01
EJ-GM23O	623 3242 33	3000 990 244
EJ-GM24B	624 3198 33	
EJ-GM25B	625 2799 00	
EJ-GM25C	625 3018 00	
EJ-GM26B	627 0872 00	
EJ-GM26C	627 3012 00	
EJ-GM28B	628 2140 09	
EJ-GM28C	628 2808 00	K1877-02
EJ-GM28C3	628 2808 33	
EJ-GM28D	628 3028 00	
EJ-GM28E	628 3029 00	
EJ-GM28J	628 0702 00	
EJ-GM30B	630 2138 00	KM11004-01
EJ-GM30C	630 3008 00	K70285-02
EJ-GM30C3	630 3008 33	
EJ-GM30D	630 0850 00	
EJ-GM30E	630 3003 00	KM11051-01
EJ-GM30E3	630 3003 33	
EJ-GM30F	630 3012 00	K70149-01
EJ-GM30FE*	630 3012 00	K70149-01
EJ-GM30G3	630 3015 33	K70303-01
EJ-GM30H	630 3029 33	K70149-02
EJ-GM30HE*	630 3029 33	K70149-02

No. De parte	No. Ref 1	No. Ref 2
EJ-GM30I	630 3027 33	K70285-01
EJ-GM30J	630 3011 00	
EJ-GM30J3	630 3011 33	
EJ-GM30K	630 3028 33	K70333-01
EJ-GM30L	631 3031 00	K1862-01
EJ-GM30M	630 3050 33	K70318-01
EJ-GM30O	630 3002 00	
EJ-GM31A	631 2352 00	K70150R-01
EJ-GM31A3	631 2352 33	
EJ-GM31D	631 1966 00	K1909-02
EJ-H19A	619 0331 60	
EJ-H21A	621 1789 60	
EJ-H21B	621 1828 60	KF702-02
EJ-H21C	621 1834 60	
EJ-H21E	621 3021 00	
EJ-H22B	622 1831 60	K70073-02
EJ-H23A	623 1672 00	KF-701-01
EJ-H24A	624 2832 00	
EJ-D30H	630 3048 00	
EJ-D30I	630 3037 00	
EJ-D31A	631 2363 00	
EJ-D31A3	631 2363 33	
EJ-D31C	631 2367 00	
EJ-D33C	633 1744 09	KM0087-02
EJ-D33D	633 1745 00	KM11001-02
EJ-D33G	417 0045 10	
EJ-F18B	618 2126 00	
EJ-F18C	618 2126 33	K62487-01
EJ-F19A	619 2428 33	K1121-01
EJ-F19B	619 3045 33	K9563-01
EJ-F20A	620 3078 00	
EJ-F20B	620 1724 00	K1122-01
EJ-F21C	622 1505 00	
EJ-F21D	625 1722 00	
EJ-F22A	622 0696 00	K0036-01
EJ-F22B	622 0725 10	K0036-02
EJ-F22H	622 2414 33	K70260-01
EJ-F22I	622 3047 00	
EJ-F22J	622 3081 33	K9568-01
EJ-F23C	623 2343 00	K70189-01
EJ-F23D	623 2570 00	K70154-02
EJ-F23D	623 2574 00	
EJ-F23D3	623 2570 33	

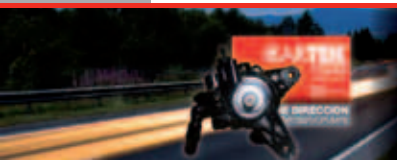

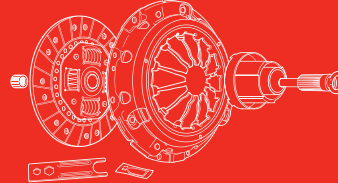

### LISTA DE EQUIVALENCIA DE NÚMERO DE PARTE

No. De parte	No. Ref 1	No. Ref 2	No. De parte	No. Ref 1	No. Ref 2	No. De parte	No. Ref 1	No. Ref 2
EJ-F23D3	623 2574 33		EJ-N20A	620 0638 69	KF587-04	EJ-F28F	628 3027 00	
EJ-F23DE*	623 2570 00	K70154-02	EJ-N20B	620 0637 60	KF532-01	EJ-F28G	628 3030 00	
EJ-F23DE*	623 2574 00		EJ-N20D	620 3089 00	K1502-01	EJ-F28H	628 3052 00	
EJ-F23DE3*	623 2570 33		EJ-N22C	622 3023 00	K70051-01	EJ-F28J	628 3056 00	
EJ-F23DE3*	623 2574 33		EJ-N23A	623 0639 69	KF594-01	EJ-F28K	628 3057 00	
EJ-F23F	623 2819 60		EJ-N23B	623 1729 60		EJ-F28L	628 3060 00	
EJ-F23H	623 2889 00		EJ-N23F	623 2844 00		EJ-F29B	629 1725 00	K70130-01
EJ-F23I	623 3060 33	K40702-01	EJ-N23H	623 3284 33		EJ-F29C	629 2348 00	K70160-01
EJ-F23J	623 3123 33	K286032-01	EJ-N24A	624 1788 00	KM168-01	EJ-F29C3	629 2348 33	
EJ-F23N	623 2797 00	K0047-05	EJ-N24B	624 2775 00	KM168-02	EJ-F29CE*	629 2348 00	K70160-01
EJ-F23N3	623 2797 33		EJ-N24D	624 2849 00		EJ-F29CE3*	629 2348 33	
EJ-F23P	623 2887 00	K0047-06	EJ-N24F	624 3030 00	K951001-01	EJ-F30B	630 2349 00	K70153-01
EJ-F23P3	623 2887 33		EJ-N24G	417 0041 10	K70355-01	EJ-F30C	631 3046 00	
EJ-F23Q	623 2803 60	K0047-07	EJ-N24H	624 97 60		EJ-F30D	630 3051 00	
EJ-F23Q3	623 2803 33		EJ-N25A	625 2306 00		EJ-F31A	631 2350 00	K70102R-01
EJ-F23S	623 2888 00	K0047-04	EJ-N25B	625 2409 00		EJ-F31B	630 3060 00	K70277R-01
EJ-F24B	624 2345 33	K70125-01	EJ-P18A	618 3003 00	K284231-01	EJ-F31BE*	630 3060 00	K70277R-01
EJ-F24C	624 2344 33	K70124-01	EJ-P20A	620 1148 00		EJ-F31C	631 2576 00	K70278R-01
EJ-F24D	624 3140 33	K311901-01	EJ-P20B	620 1612 00	K857602-01	EJ-F31CE*	631 2576 00	K70278R-01
EJ-F24E	417 0044 33		EJ-P20C	620 3087 00	K307804-02	EJ-F31D	630 3024 00	
EJ-F25D	625 2890 00	K70160-02	EJ-P20D	620 3084 00	K307804-01	EJ-F33F	633 3028 00	K70241-01
EJ-F25D3	625 2890 33		EJ-P22B	622 0618 00		EJ-F33G	633 3037 11	
EJ-F25D3	625 2890 33		EJ-P23A	623 3043 00	K631701-01	EJ-F33H	633 3063 00	
EJ-F25E	625 3009 00	K0116-02	EJ-R22B	622 3040 00	K826034-01	EJ-FI20A	620 3032 00	
EJ-F25E3	625 3009 33		EJ-R24B	624 3200 09		EJ-GE20A	620 1721 60	K1117-01
EJ-F25F	625 3017 00		EJ-SE22A	622 3089 00	K309909-01	EJ-GE20C	620 3030 00	K70240-1
EJ-IS20A	620 2815 60		EJ-TY19B	620 2863 60		EJ-GM19A	619 2340 00	KM80203-01
EJ-IS22A	622 0895 60		EJ-TY20B	620 3094 00	K0076-01	EJ-GM19D	619 3056 00	K632701-01
EJ-IS24A	624 87 60		EJ-TY22E	622 3002 60	K70079-03	EJ-GM20C	620 2175 00	K6508-01
EJ-MA22D	623 3168 60	K70367-01	EJ-TY23A	623 2864 60		EJ-GM20D	620 2375 33	K172031-01
EJ-MA22D	623 3168 60	K70397-01	EJ-TY23B	623 0310 60		EJ-GM21A	621 2378 33	K260031-01
EJ-MA22E	622 0909 60		EJ-TY23C	623 0982 60		EJ-GM21B	621 3009 00	
EJ-MA23B		K70368-01	EJ-TY23H	623 3022 00		EJ-GM21D	622 3035 33	K70315-01
EJ-MA23D	623 0585 60		EJ-TY24A	624 2867 60		EJ-GM21E	622 3051 00	
EJ-MA23E	623 2398 60		EJ-F25G	625 3020 00		EJ-GM21F	621 2424 33	K1587-01
EJ-MA24A	624 1627 60		EJ-F25J	625 3013 00		EJ-GM22A	622 1198 60	K837002-01
EJ-MA25A	625 2829 00		EJ-F25K	625 3025 00		EJ-GM22A2	622 3028 00	
EJ-MA26A	626 3017 00	K70313-01	EJ-F25K3	625 3025 33		EJ-GM22B	622 2139 33	K70156-01
EJ-MI23A	623 0578 60		EJ-F27A	627 2159 00	K0048-01	EJ-GM22D	621 3022 00	K837002-02
EJ-MI23B	623 1872 60		EJ-F28A4	628 0723 00	K0465-05	EJ-GM22E	622 1495 00	K1915-02
EJ-N18A	618 0640 17	KF537-04	EJ-F28B	628 0732 00	KM173-01	EJ-GM22F	622 3149 00	3000 951 403
EJ-N19A	619 0846 67	KM639-02	EJ-F28C	628 1196 00		EJ-GM23A	623 1195 00	K0119-01
EJ-N19B2	619 3043 09		EJ-F28E	628 3021 00		EJ-TY24B	624 0985 60	



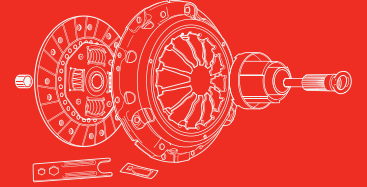

### LISTA DE EQUIVALENCIA DE NÚMERO DE PARTE

No. De parte	No. Ref 1	No. Ref 2
EJ-TY24C	624 3133 60	
EJ-TY24E	624 2865 60	
EJ-TY24F	624 1768 60	
EJ-TY25A	625 3010 00	K70116-01
EJ-TY25A	625 3010 00	K70116-02
EJ-VA26A	627 0730 00	
EJ-VW19A	619 0004 06	K1886-01
EJ-VW20A	620 0007 16	KF224-02B
EJ-VW20B	620 0007 06	KF224-01
EJ-VW20B2	620 0641 10	
EJ-VW20C	620 0077 06	K0028-01
EJ-VW20D	620 0078 09	
EJ-VW20F	620 3091 00	K108137-01
EJ-VW21A	621 0283 06	K70037-02
EJ-VW21A	621 0283 06	KF295-01
EJ-VW21A	621 0853 00	
EJ-VW21B	621 1748 00	K70128-01
EJ-VW21B2	621 1749 00	K70128-04

No. De parte	No. Ref 1	No. Ref 2
EJ-VW21C	621 2078 00	K9082-01
EJ-VW21D	621 1746 00	K70037-01
EJ-VW22A	622 2400 00	K194603-01
EJ-VW22C	623 2167 00	
EJ-VW22D	417 9019 10	
EJ-VW22E	417 9016 10	K70245-01
EJ-VW22ES*	417 9016 10	K70245-01
EJ-VW23A	623 0129 06	KF251-01
EJ-VW23B	623 1197 00	K70038-03
EJ-VW23E	623 0818 00	K70038-01
EJ-VW23G	417 9037 10	K70423-01
EJ-VW24A	417 0031 33	K70245-01

### CSC (Cilindro esclavo concéntrico)

No. De parte	No. Ref 1	No. Ref 2
EC-F19A	510 0011 10	
EC-F23I	510 0023 10	
EC-F24B	510 0067 10	
EC-F23J	510 0001 10	
EC-F29A3	510 0046 10	SFC-893
EC-F23N3	510 0044 10	SFC-748
EC-F23P3	510 0045 10	SFC-890
EC-GM21F	510 0073 10	
EC-GM21F1	510 0073 10	
EC-GM22B	510 0069 10	
EC-GM23B	510 0070 10	
EC-GM23M	510 0051 20	
EC-GM30H	510 0050 10	SGC-901
EC-GM31A3	510 0041 10	SGC-944

\*El producto funciona para la misma aplicación aunque tiene diferentes características

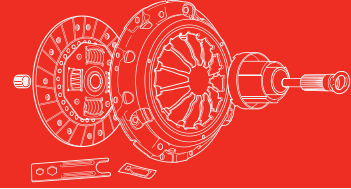

## POLIZA DE GARANTÍA

**MAYOREO DE AUTOPARTES Y ACEITES S. A. de C. V.**, garantiza que sus productos cumplen con las normas de materiales y mano de obra requeridos dentro del proceso de fabricación y empaque. Nuestra garantía cubre 1 año o 40,000km, lo que ocurra primero, a partir de su instalación previendo un uso normal, acorde a las especificaciones del fabricante del vehículo, así como una correcta instalación debiendo reemplazar el disco, plato, collarín y buje o balero piloto (donde aplique) y el volante de motor sea rectificado según las especificaciones del fabricante según espesor y/o altura de caja (donde aplique), o en caso necesario reemplazado. **MAYOREO DE AUTOPARTES Y ACEITES S. A. de C. V.**, se reserva el derecho de aceptar o rechazar la garantía del producto previo dictamen correspondiente por parte de su departamento técnico. Esta garantía no cubre costos de mano de obra y/o gastos derivados (ejemplo: grúa, etc.), ni aplica cuando el número de Kit no corresponda al vehículo donde se instaló o cuando presente alguna de las condiciones descritas como causas de exclusión en la parte baja de esta póliza. Esta garantía en caso de ser validada por el departamento técnico de **MAYOREO DE AUTOPARTES Y ACEITES S. A. de C. V.**, solo cubre el reemplazo físico del Kit, por otro Kit del mismo número de parte reclamado. Todo Kit de clutch que sea reclamado en garantía deberá de ser regresado con todas y cada una de sus partes independiente del estado de cada una, a la refaccionaria o establecimiento donde fue adquirido o en su defecto con un distribuidor autorizado de **MAYOREO DE AUTOPARTES Y ACEITES S. A. de C. V.**, especificando debidamente la fecha de instalación y llenando el formato de reclamación de garantía (FR60TE) proporcionado por el distribuidor autorizado **CARTEK®** en el que se deberá de dar una descripción detallada del síntoma que presenta el producto. Para cualquier aclaración o duda, favor de comunicarse al departamento de Asistencia Técnica al teléfono **01-800-836- 1456 ó 01-800-CARTEKS**, o bien vía correo electrónico a [asistecnica@perfmex.com](mailto:asistecnica@perfmex.com) donde será atendido.



### CONTAMINACIÓN CON ACEITE O GRASA

Un plato o disco contaminado con grasa o aceite de algún retén de cigüeñal defectuoso o flecha de mando lubricada en exceso, ocasiona fallas como la trepidación (temblor) o el patinado del clutch.



### CONTAMINACIÓN CON ACEITE O GRASA

Un plato o disco contaminado con grasa o aceite de algún retén de cigüeñal defectuoso o flecha de mando lubricada en exceso, ocasiona fallas como la trepidación (temblor) o el patinado del clutch.



### DAÑO/DESGASTE EXCESIVO EN EL ESTRIADO DEL DISCO

El desgaste en la flecha de mando y/o la instalación forzada de la transmisión ocasionan daños en el estriado de la maza del disco.



### PRESENCIA DE ÓXIDO EN ALGÚN COMPONENTE

Producto almacenado y expuesto a humedad en exceso, sufre alteraciones que inciden de forma considerable el mal funcionamiento del producto y reduce su vida útil.



### LOGOTIPOS O NÚMEROS DE EQUIPO ORIGINAL

Perfection no distribuye platos, discos o collarines con logotipos o números de equipo original en el mercado de repuestos mexicano.



### ENVÍO DE PRODUCTO INCOMPLETO

Es indispensable contar con cada uno de los componentes del Kit (plato, disco y collarín) para poder dar trámite a la recepción de producto bajo reclamación de garantía.



### FALTA DE DESCRIPCIÓN DE SÍNTOMAS O FALLAS

A todo producto reclamado por garantía se le debe adjuntar un documento que describa cuál es la falla por la cual está siendo solicitada.



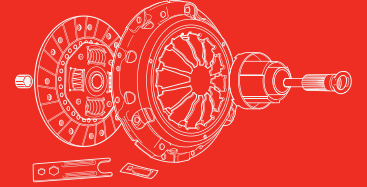

## MÁXIMA DURABILIDAD A UN COSTO COMPETITIVO

Las Vehículos de trabajo hoy en día requieren productos de recambio que brinden durabilidad, confort pero principalmente un mejor costo beneficio al del promedio del mercado. Por esa razón, MAYOREO DE AUTOPARTES Y ACEITES S. A. de C. V., desarrolló un Kit de Clutch para unidades que son sometidas diariamente a severas condiciones de trabajo.

Los Kits de Clutch CARTEK®, en Versión NO Autoajustable cumplen con los requerimientos de Calidad de Equipo Original y cuentan con una Garantía contra defectos de fabricación de 1 Año ó 40,000Km a partir de la fecha de su instalación.

### Guía rápida de referencia:

Número de parte	Número de referencia
EJ-F23DE	(ConBalero) 6232570 00
EJ-F23DE3	(Con CSC) 623 2570 33
EJ-F23DE	(ConBalero) 6232574 00
EJ-F23DE3	(Con CSC) 623 2574 33
EJ-F23DE3	(Con CSC) 623 3161 33
EJ-F29CE	(ConBalero) 6292347 00
EJ-F29CE3	(Con CSC) 629 2347 33
EJ-F29CE	(ConBalero) 6292348 00
EJ-F29CE3	(Con CSC) 629 2348 33
EJ-F31BE	630 3060 00
EJ-F31CE	631 2576 00
EJ-GM30FE	(ConBalero) 6303012 00
EJ-GM30FE3	(Con CSC) 630 3012 33
EJ-GM30HE	(Con CSC) 630 3029 33



EJ-F31BE  
Ford F-350 - Triton 5.4L  
Versión NO autoajustable

## ALTERNATIVAS A EMBRAGUES AUTOAJUSTABLES

- > PISTONES PARA CALIPER
- > KITS DE CALIPER
- > KITS PARA RUEDA
- > KITS DE TAMBOR

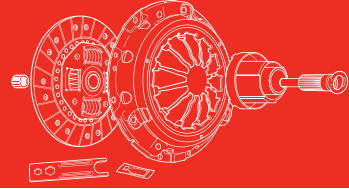

## Notas

**CARTEK**<sup>®</sup>



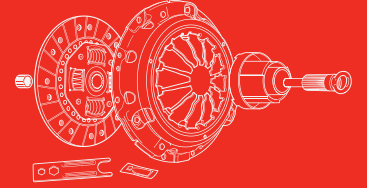

## Notas

**CARTEK**<sup>®</sup>



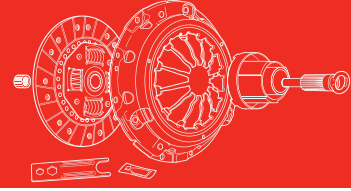

## Notas

**CARTEK**<sup>®</sup>



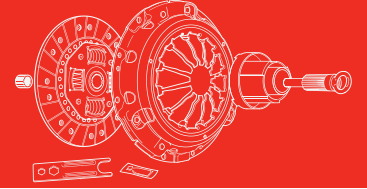

## Notas

**CARTEK**<sup>®</sup>



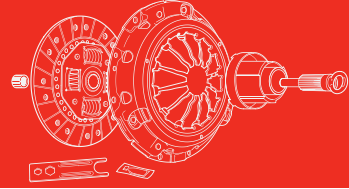

## Notas

CARTEK<sup>®</sup>



**NUEVO**

**CARTEK**  
AUTOPARTES

» **FILTRO DE AIRE**  
» **FILTRO DE GASOLINA**

**NUEVO**

EUROPERFORMANCE  
MÁS CALIDAD PARA CALIPER

**CARTEK**

» **PISTONES PARA CALIPER**  
» **KITS DE CALIPER**  
» **KITS PARA RUEDA**  
» **KITS DE TAMBOR**

**NUEVO**

**CARTEK**  
IGNITION COILE EUROPERFORMANCE  
**BOBINAS**

Venta directa en México contactar:  
01 800 627.2044 Guadalajara, Jal.  
01 800 711.6368 Morelia, Mich.  
01 800 633.5455 Culiacán, Sin.

Distribuciones en Latinoamérica de productos  
CARTEK contactar: (+52) 33 3837.5610



SPECIFICALLY DEVELOPED FOR THE AUTOMOTIVE INDUSTRY  
QUALITÄT IST SCHÖN, HALTBAR, MACHT FREUDE UND YAHLT SICH AUS

[www.carttek.com.mx](http://www.carttek.com.mx)



# CARTEK®

AUTOPARTES

www.carttek.com.mx

**NUEVO**

**CARTEK**  
AUTOPARTES

► FILTRO DE AIRE  
► FILTRO DE GASOLINA

**CARTEK**  
FILTRO DE AIRE

www.carttek.com.mx

**NUEVO**

**CARTEK**  
ULTRAPERFORMANCE

► PISTONES PARA CALIPER  
► KITS DE CALIPER  
► KITS PARA RUEDA  
► KITS DE TAMBOR

www.carttek.com.mx

**NUEVO**

**CARTEK**  
IGNITION COILS ULTRAPERFORMANCE

**BOBINAS**

**CARTEK**  
AMPERTRON

**MÁXIMO PODER DE ARRANQUE**

LIBRE DE MANTENIMIENTO

**MOTION**  
MOTOR OIL

**MOTION**  
MOTOR OIL

**CARTEK**

PARTES HIDRAULICAS  
BALATAS SEMIMETALICAS

**BOMBA DE AGUA  
FAN CLUTCH**

**CARTEK**  
ROTORES Y TAMBORES

**BOMBA DE GASOLINA**

**CABLES PARA BUJIA**

**CARTEK**  
SMARTPLUG

**CREMALLERA Y PIÑON  
BOMBAS DE DIRECCIÓN**

**CARTEK**  
SISTEMAS HIDRÁULICOS

**IC Innovation**  
HYDRAULIC SYSTEMS

**MAZAS DE RUEDA  
RODAMIENTOS**

**CARTEK**  
MOLAS Y TENSORES

**POLEAS Y TENSORES  
KITS DE DISTRIBUCIÓN**

**JUNTAS HOMOCINETICAS**

**CARTEK**  
SOPORTES

**CARTEK**  
SIN ASBESTOS Y PLOMO

**HEAVYDUTY  
USO EXTREMO**

**CARTEK**  
Anticongelante  
Hidráulico

**LIQUIDO PARA FRENOS**

**CARTEK**  
SERVICIO TECNICO



**01800CARTEKS**  
**018002278357**