



LT-2018

INDUSTRIAS AUTOMOTRICES



Partes de transmisión
Transmission parts

www.lodi.com.mx

¡NUEVO CATÁLOGO!

LG-2018

CATÁLOGO DE PARTES



**Poleas de cigüeñal | Juegos de sellos para motor
Partes para frenos | Partes para dirección | Guías de válvula
Tapas de distribución | Abrazaderas | Purificadores
Aumentos para bujías | Terminales de batería**

MAX[®]

performance

NUEVA LÍNEA VALVULA SOLENOIDE DE TIEMPO VARIABLE

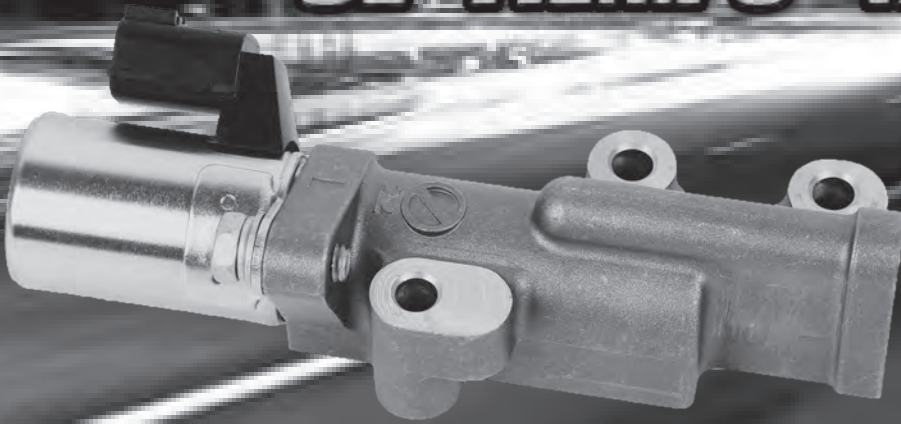

Solicita nuestro catálogo
con tu distribuidor



	Iniciales	Pag.
	POLITICA DE GARANTÍA	3
1	PARTES PARA TRANSMISIÓN	
	Información técnica aro automático	4
1.1	Aros dentados transmisión automática AA	5-29
1.2	Aros dentados transmisión estándar AS	31-33
1.3	Aros dentados transmisión estándar dimensiones	33-34
1.4	Partes y repuestos para transmisión automática JDA, JDF, JC	35-38
	Información técnica filtro y empaque de transmisión automática	39-40
1.5	Filtro y empaque de transmisión automática FC	41-97
1.6	Moduladores MO	99-100
1.7	Volantes estándar WOH	101-105
2	PARTES PARA SISTEMA DE EMBRAGUE	
2.1	Horquilla de clutch HC, SHC	106-110
2.2	Tornillo de horquilla de clutch THC	111-113
2.3	Maromas y balancines MOB	113-114
2.4	Tornillo o varilla de ajuste para horquilla de clutch T	114
2.5	Templadores, ajustes, porta horquillas de clutch y seguros CAC, PH, M, CHP, SAP, TC	115
3	PIEZAS VARIAS	
3.1	Tuercas para caja de velocidades TCV, TCM	116-117
4	PARTES PARA EJE TRASERO	
4.1	Arañas, guasas y tuercas de housing AH,GH,TH,SB,JTA	118-120
5	PARTES PARA BARRA CARDAN	
5.1	Soportes para barra cardan BC, HS, B, GP	122-129
6	TABLAS DE EQUIVALENCIAS	
6.1	Filtro y empaque de transmisión automática	130-134

Abreviaturas

A	Admisión	D.I.	Diametro interior	N.D.	No disponible	TT	Tracción trasera
CC	Centímetros cubicos	D. Std.	Dirección standard	NR	No requiere	U.D.	Universal Delgada
CID	Cubic Inch displacement	E	Escape	OEM	Original equipment manufacturer	U.G.	Universal Gruesa
Cil.	Cilindros	EC	Estriado completo	TC	Tornillos de carter	VEL.	Velocidades
D.E.	Diametro exterior	EP	Estriado plano	TD	Tracción delantera	N	Nueva Aplicación
D. Hidr.	Dirección hidraulica	L	Litros				



INDUSTRIAS AUTOMOTRICES

GARANTÍA LIMITADA

Nuestras piezas están garantizadas contra defectos de material o fabricación. Se reponen con mercancía equivalente únicamente las piezas que resulten defectuosas.

Nuestra compañía no asume la responsabilidad por daños consecuentes o incidentales bajo ninguna circunstancia. En ningún caso se aceptarán cargos por otros conceptos.

La garantía solamente es válida para nuestros clientes directos.

La información en este catálogo está correcta a nuestro alcance, puesto que ha sido recopilada de fuentes fiables, aun así no nos hacemos responsables por algún posible error en ella.

NOTA: Los números originales mencionados en este catálogo son utilizados únicamente como referencia para facilitar la localización de la refacción, ya que nosotros utilizamos nuestra propia nomenclatura para nuestras piezas.

No se pretende que nuestras piezas pasen como equipo original.

LIMITED GUARANTEE

Our products are guaranteed against defects in material and workmanship. Our obligation is limited to replacement of the defective part.

Our company is not responsible for any incidental or consequential damages which may result. We will not accept any charge.

The guarantee is only given to our direct customers.

The information in this catalog is correct to the best of our knowledge. However, we will not assume any responsibility for any possible error or omission.

NOTE: The original numbers mentioned in this catalog are used only as a reference, we have our numbers replacement parts. There is no intent to represent any part herein as being that of the original equipment manufacturer.

¿POR QUÉ SE FRACTURA UN ARO AUTOMÁTICO ALREDEDOR DEL CIGUEÑAL O DE LOS PUNTOS DE APOYO DEL CONVERTIDOR DE TORQUE (TURBINA)?

Los daños en la estructura del aro automático es más a menudo debido a una falla de instalación y/o problemas de balanceo entre el motor y la transmisión.

Cuando esto ocurre, pueden ser varias las causas:

- 1) Falla al instalar el aro automático cuando este no queda completamente perpendicular a la base del cigüeñal.
- 2) Convertidor de torque (turbina) fuera de balance.
- 3) Buje frontal (de la bomba) de la transmisión desgastado.
- 4) Demasiado juego del cigüeñal debido al excesivo desgaste de los cojinetes (metales de cigüeñal).
- 5) Falla por no dar el torque correcto a los tornillos de acuerdo a las y a la secuencia correcta de los mismos.
- 6) Motor de arranque (marcha) en malas condiciones puede causar en los dientes o en el aro dentado un rápido desgaste o ruptura.

7) En algunas aplicaciones de GM, un espaciador especial o *laina* es requerida para alinear correctamente

el motor de arranque con el aro dentado. En tales casos cuando el espaciador es necesario y no fue instalado puede ocurrir daño en el aro dentado.

8) En vehículos de la marca Nissan, el no colocar las guías de la transmisión, ocasiona que se genere una fuerza axial al centro del aro dentado, teniendo como consecuencia que este se estrellé y/o fracture del centro.

TIPS DE IMPORTANCIA

- A) Nunca sobre-torque los tornillos.
- B) Siempre use un torquimetro.
- C) Nunca emplee herramienta neumática para instalarlo.
- D) Procure usar tornillos nuevos al instalar un nuevo aro automático.

Nota: En todo aro dentado que presente este tipo de daño, no procede la garantía.

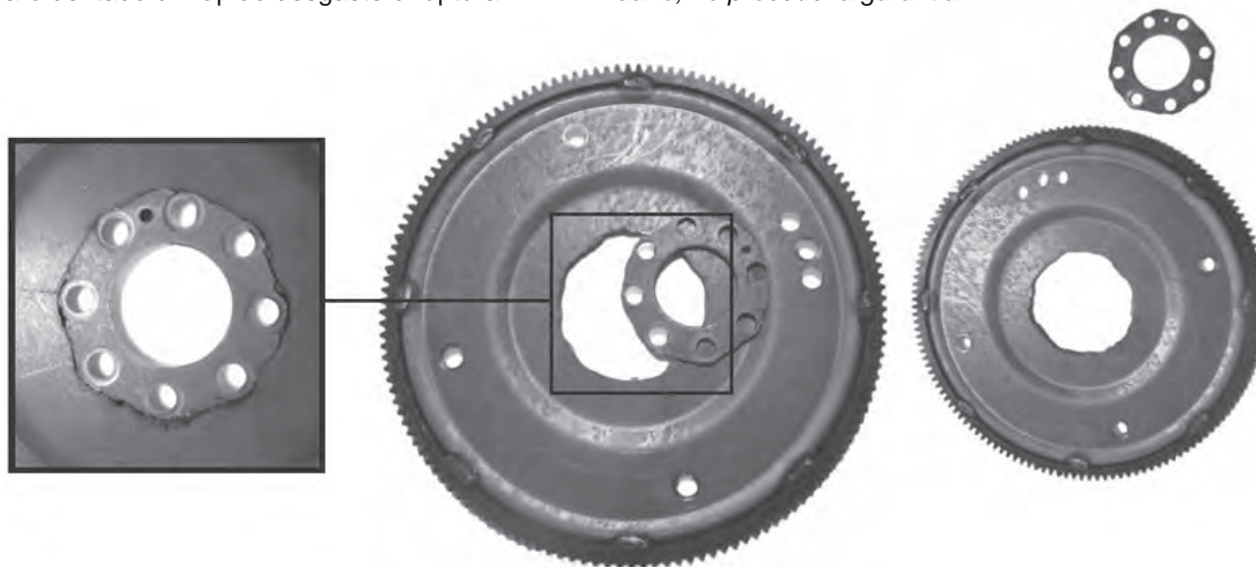











1.1 Aros dentados transmisión automática

Automatic transmission flex plates



American Motor Company / Jeep

 <p>AA-A300</p>	<table border="1"> <tr><td>Dientes</td><td>164</td></tr> <tr><td>Contrapeso</td><td>No</td></tr> <tr><td>Diám Ext.</td><td>13.83"</td></tr> <tr><td>OEM</td><td>3232138</td></tr> <tr><td colspan="2">L6 232, 252, 258 Gremlin, Jeep, Pacer y Rambler (72-88)</td></tr> </table>	Dientes	164	Contrapeso	No	Diám Ext.	13.83"	OEM	3232138	L6 232, 252, 258 Gremlin, Jeep, Pacer y Rambler (72-88)		 <p>AA-A301</p>	<table border="1"> <tr><td>Dientes</td><td>164</td></tr> <tr><td>Contrapeso</td><td>Si</td></tr> <tr><td>Diám Ext.</td><td>13.83"</td></tr> <tr><td>OEM</td><td>3232139</td></tr> <tr><td colspan="2">V8 304, 360 AMC / Jeep (72-87)</td></tr> </table>	Dientes	164	Contrapeso	Si	Diám Ext.	13.83"	OEM	3232139	V8 304, 360 AMC / Jeep (72-87)	
Dientes	164																						
Contrapeso	No																						
Diám Ext.	13.83"																						
OEM	3232138																						
L6 232, 252, 258 Gremlin, Jeep, Pacer y Rambler (72-88)																							
Dientes	164																						
Contrapeso	Si																						
Diám Ext.	13.83"																						
OEM	3232139																						
V8 304, 360 AMC / Jeep (72-87)																							
 <p>AA-A302</p>	<table border="1"> <tr><td>Dientes</td><td>164</td></tr> <tr><td>Contrapeso</td><td>No</td></tr> <tr><td>Diám Ext.</td><td>13.83"</td></tr> <tr><td>OEM</td><td>5351819</td></tr> <tr><td colspan="2">L6 232 y 258 AMC / Jeep (74-79) (excepto Jeeps Serv. Postal USA)</td></tr> </table>	Dientes	164	Contrapeso	No	Diám Ext.	13.83"	OEM	5351819	L6 232 y 258 AMC / Jeep (74-79) (excepto Jeeps Serv. Postal USA)		 <p>AA-A303</p>	<table border="1"> <tr><td>Dientes</td><td>164</td></tr> <tr><td>Contrapeso</td><td>No</td></tr> <tr><td>Diám Ext.</td><td>13.83"</td></tr> <tr><td>OEM</td><td>5351821</td></tr> <tr><td colspan="2">V8 360 AMC / Jeep (74-79) w/ TH400</td></tr> </table>	Dientes	164	Contrapeso	No	Diám Ext.	13.83"	OEM	5351821	V8 360 AMC / Jeep (74-79) w/ TH400	
Dientes	164																						
Contrapeso	No																						
Diám Ext.	13.83"																						
OEM	5351819																						
L6 232 y 258 AMC / Jeep (74-79) (excepto Jeeps Serv. Postal USA)																							
Dientes	164																						
Contrapeso	No																						
Diám Ext.	13.83"																						
OEM	5351821																						
V8 360 AMC / Jeep (74-79) w/ TH400																							
 <p>AA-A305</p>	<table border="1"> <tr><td>Dientes</td><td>164</td></tr> <tr><td>Contrapeso</td><td>No</td></tr> <tr><td>Diám Ext.</td><td>13.83"</td></tr> <tr><td>OEM</td><td>3184926</td></tr> <tr><td colspan="2">V8 360 AMC / Jeep (71-73)</td></tr> </table>	Dientes	164	Contrapeso	No	Diám Ext.	13.83"	OEM	3184926	V8 360 AMC / Jeep (71-73)		 <p>AA-A306</p>	<table border="1"> <tr><td>Dientes</td><td>164</td></tr> <tr><td>Contrapeso</td><td>No</td></tr> <tr><td>Diám Ext.</td><td>13.83"</td></tr> <tr><td>OEM</td><td>3184927</td></tr> <tr><td colspan="2">V8 304 AMC / Jeep (71-73)</td></tr> </table>	Dientes	164	Contrapeso	No	Diám Ext.	13.83"	OEM	3184927	V8 304 AMC / Jeep (71-73)	
Dientes	164																						
Contrapeso	No																						
Diám Ext.	13.83"																						
OEM	3184926																						
V8 360 AMC / Jeep (71-73)																							
Dientes	164																						
Contrapeso	No																						
Diám Ext.	13.83"																						
OEM	3184927																						
V8 304 AMC / Jeep (71-73)																							
 <p>AA-A307</p>	<table border="1"> <tr><td>Dientes</td><td>164</td></tr> <tr><td>Contrapeso</td><td>No</td></tr> <tr><td>Diám Ext.</td><td>13.83"</td></tr> <tr><td>OEM</td><td>5351820</td></tr> <tr><td colspan="2">V8 304 AMC / Jeep (74-79)</td></tr> </table>	Dientes	164	Contrapeso	No	Diám Ext.	13.83"	OEM	5351820	V8 304 AMC / Jeep (74-79)		 <p>AA-A308</p>	<table border="1"> <tr><td>Dientes</td><td>164</td></tr> <tr><td>Contrapeso</td><td>Si</td></tr> <tr><td>Diám Ext.</td><td>13.83"</td></tr> <tr><td>OEM</td><td>5351822</td></tr> <tr><td colspan="2">V8 401 AMC / Jeep (74-78)</td></tr> </table>	Dientes	164	Contrapeso	Si	Diám Ext.	13.83"	OEM	5351822	V8 401 AMC / Jeep (74-78)	
Dientes	164																						
Contrapeso	No																						
Diám Ext.	13.83"																						
OEM	5351820																						
V8 304 AMC / Jeep (74-79)																							
Dientes	164																						
Contrapeso	Si																						
Diám Ext.	13.83"																						
OEM	5351822																						
V8 401 AMC / Jeep (74-78)																							
 <p>AA-A309</p>	<table border="1"> <tr><td>Dientes</td><td>164</td></tr> <tr><td>Contrapeso</td><td>No</td></tr> <tr><td>Diám Ext.</td><td>13.83"</td></tr> <tr><td>OEM</td><td>5900002</td></tr> <tr><td colspan="2">L6 232 AMC / Jeep (72-75) (Jeep del Servicio Postal USA)</td></tr> </table>	Dientes	164	Contrapeso	No	Diám Ext.	13.83"	OEM	5900002	L6 232 AMC / Jeep (72-75) (Jeep del Servicio Postal USA)		 <p>AA-A310</p>	<table border="1"> <tr><td>Dientes</td><td>164</td></tr> <tr><td>Contrapeso</td><td>No</td></tr> <tr><td>Diám Ext.</td><td>13.83"</td></tr> <tr><td>OEM</td><td>33004359</td></tr> <tr><td colspan="2">L6 258 AMC / Jeep Wrangler (87-90)</td></tr> </table>	Dientes	164	Contrapeso	No	Diám Ext.	13.83"	OEM	33004359	L6 258 AMC / Jeep Wrangler (87-90)	
Dientes	164																						
Contrapeso	No																						
Diám Ext.	13.83"																						
OEM	5900002																						
L6 232 AMC / Jeep (72-75) (Jeep del Servicio Postal USA)																							
Dientes	164																						
Contrapeso	No																						
Diám Ext.	13.83"																						
OEM	33004359																						
L6 258 AMC / Jeep Wrangler (87-90)																							

1.1 Aros dentados transmisión automática

Automatic transmission flex plates



American Motor Company / Jeep

	AA-A311	Dientes	164
		Contrapeso	Si
		Diám Ext.	13.83"
		OEM	33004361
	V8 360 AMC / Jeep Grand Wagoneer (88-91)		

	AA-A312	Dientes	164
		Contrapeso	Si
		Diám Ext.	13.83"
		OEM	3232141
	V8 401 AMC (72-76)		

	AA-A313	Dientes	164
		Contrapeso	No
		Diám Ext.	13.83"
		OEM	5351485
	L6 232 y 258 AMC / Jeep (71-73) (excepto Jeeps Serv. Postal USA)		

	AA-A314	Dientes	148
		Contrapeso	Si
		Diám Ext.	12.40"
		OEM	53001255
	V6 173 AMC / Jeep (84-86) (motor Chevrolet)		

	AA-A315	Dientes	148
		Contrapeso	No
		Diám Ext.	12.50"
		OEM	33002842
	L4 150 (2.5L) Eagle Premier (88-89)		

	AA-A316	Dientes	164
		Contrapeso	No
		Diám Ext.	13.83"
		OEM	33002675
	L6 242 (4.0L) Jeep Cherokee, Comanche (87-90)		

	AA-A317	Dientes	148
		Contrapeso	No
		Diám Ext.	12.40"
		OEM	53001184
	L4 150 (2.5L) Jeep Cherokee, CJ7 (83-85) (motor Jeep)		

	AA-A318	Dientes	164
		Contrapeso	No
		Diám Ext.	13.83"
		OEM	52117761 / 52118551
	L6 4.0L Jeep Cherokee, Wrangler, Grand Cherokee (91-96)		

	AA-A319	Dientes	164
		Contrapeso	No
		Diám Ext.	13.83"
		OEM	53006328
	L6 4.0L Jeep Grand Cherokee (93-95), Jeep Wrangler (91-04)		









	AA-A320	Dientes	164
		Contrapeso	No
		Diám Ext.	13.83"
		OEM	52118257
	L6 4.0L Jeep Cherokee, Grand Cherokee (97-03) (turbina 90°)		

1.1 Aros dentados transmisión automática

Automatic transmission flex plates

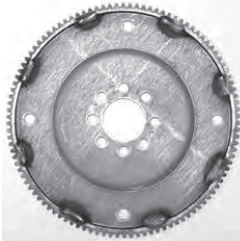

Chrysler / Dodge

<p>AA-C400</p> 	<table border="1"> <tr><td>Dientes</td><td>139</td></tr> <tr><td>Contrapeso</td><td>No</td></tr> <tr><td>Diám Ext.</td><td>11.75"</td></tr> <tr><td>OEM</td><td>4736016</td></tr> <tr><td colspan="2">V6 2.5L, 3.3L, 3.8L (90-00)</td></tr> </table>	Dientes	139	Contrapeso	No	Diám Ext.	11.75"	OEM	4736016	V6 2.5L, 3.3L, 3.8L (90-00)		<p>AA-C401</p> 	<table border="1"> <tr><td>Dientes</td><td>139</td></tr> <tr><td>Contrapeso</td><td>No</td></tr> <tr><td>Diám Ext.</td><td>11.75"</td></tr> <tr><td>OEM</td><td>4348286</td></tr> <tr><td colspan="2">L4 135 (2.2L), Serie K (81-85)</td></tr> </table>	Dientes	139	Contrapeso	No	Diám Ext.	11.75"	OEM	4348286	L4 135 (2.2L), Serie K (81-85)	
Dientes	139																						
Contrapeso	No																						
Diám Ext.	11.75"																						
OEM	4736016																						
V6 2.5L, 3.3L, 3.8L (90-00)																							
Dientes	139																						
Contrapeso	No																						
Diám Ext.	11.75"																						
OEM	4348286																						
L4 135 (2.2L), Serie K (81-85)																							
<p>AA-C402</p> 	<table border="1"> <tr><td>Dientes</td><td>139</td></tr> <tr><td>Contrapeso</td><td>No</td></tr> <tr><td>Diám Ext.</td><td>11.75"</td></tr> <tr><td>OEM</td><td>4348287</td></tr> <tr><td colspan="2">L4 156 (2.6L), Serie K (81-85) (motor Mitsubishi)</td></tr> </table>	Dientes	139	Contrapeso	No	Diám Ext.	11.75"	OEM	4348287	L4 156 (2.6L), Serie K (81-85) (motor Mitsubishi)		<p>AA-C403</p> 	<table border="1"> <tr><td>Dientes</td><td>N / A</td></tr> <tr><td>Contrapeso</td><td>N / A</td></tr> <tr><td>Diám Ext.</td><td>12.125"</td></tr> <tr><td>OEM</td><td>2204768</td></tr> <tr><td colspan="2">V8 318, 340, 360, 383, 426, 440 (62-77) (trans. A727 / TF8)</td></tr> </table>	Dientes	N / A	Contrapeso	N / A	Diám Ext.	12.125"	OEM	2204768	V8 318, 340, 360, 383, 426, 440 (62-77) (trans. A727 / TF8)	
Dientes	139																						
Contrapeso	No																						
Diám Ext.	11.75"																						
OEM	4348287																						
L4 156 (2.6L), Serie K (81-85) (motor Mitsubishi)																							
Dientes	N / A																						
Contrapeso	N / A																						
Diám Ext.	12.125"																						
OEM	2204768																						
V8 318, 340, 360, 383, 426, 440 (62-77) (trans. A727 / TF8)																							
<p>AA-C404</p> 	<table border="1"> <tr><td>Dientes</td><td>N / A</td></tr> <tr><td>Contrapeso</td><td>N / A</td></tr> <tr><td>Diám Ext.</td><td>10.75"</td></tr> <tr><td>OEM</td><td>4058429</td></tr> <tr><td colspan="2">L6 225, V8 318, 340, 360, 383, 426, 440 (62-89) (trans. A904 / TF6)</td></tr> </table>	Dientes	N / A	Contrapeso	N / A	Diám Ext.	10.75"	OEM	4058429	L6 225, V8 318, 340, 360, 383, 426, 440 (62-89) (trans. A904 / TF6)		<p>AA-C405</p> 	<table border="1"> <tr><td>Dientes</td><td>N / A</td></tr> <tr><td>Contrapeso</td><td>N / A</td></tr> <tr><td>Diám Ext.</td><td>12.125"</td></tr> <tr><td>OEM</td><td>2204719</td></tr> <tr><td colspan="2">L6 198, 225, (62-77) (trans. A904 / TF6)</td></tr> </table>	Dientes	N / A	Contrapeso	N / A	Diám Ext.	12.125"	OEM	2204719	L6 198, 225, (62-77) (trans. A904 / TF6)	
Dientes	N / A																						
Contrapeso	N / A																						
Diám Ext.	10.75"																						
OEM	4058429																						
L6 225, V8 318, 340, 360, 383, 426, 440 (62-89) (trans. A904 / TF6)																							
Dientes	N / A																						
Contrapeso	N / A																						
Diám Ext.	12.125"																						
OEM	2204719																						
L6 198, 225, (62-77) (trans. A904 / TF6)																							
<p>AA-C406</p> 	<table border="1"> <tr><td>Dientes</td><td>N / A</td></tr> <tr><td>Contrapeso</td><td>N / A</td></tr> <tr><td>Diám Ext.</td><td>10.75"</td></tr> <tr><td>OEM</td><td>4058428</td></tr> <tr><td colspan="2">L6 198, 225, (62-87) (trans. A904 / TF6)</td></tr> </table>	Dientes	N / A	Contrapeso	N / A	Diám Ext.	10.75"	OEM	4058428	L6 198, 225, (62-87) (trans. A904 / TF6)		<p>AA-C407</p> 	<table border="1"> <tr><td>Dientes</td><td>106</td></tr> <tr><td>Contrapeso</td><td>No</td></tr> <tr><td>Diám Ext.</td><td>10.68"</td></tr> <tr><td>OEM</td><td>4567143</td></tr> <tr><td colspan="2">L4 2.0L, 2.4L Neon, Stratus, Sebring (95-06)</td></tr> </table>	Dientes	106	Contrapeso	No	Diám Ext.	10.68"	OEM	4567143	L4 2.0L, 2.4L Neon, Stratus, Sebring (95-06)	
Dientes	N / A																						
Contrapeso	N / A																						
Diám Ext.	10.75"																						
OEM	4058428																						
L6 198, 225, (62-87) (trans. A904 / TF6)																							
Dientes	106																						
Contrapeso	No																						
Diám Ext.	10.68"																						
OEM	4567143																						
L4 2.0L, 2.4L Neon, Stratus, Sebring (95-06)																							
<p>AA-C408</p> 	<table border="1"> <tr><td>Dientes</td><td>139</td></tr> <tr><td>Contrapeso</td><td>No</td></tr> <tr><td>Diám Ext.</td><td>11.75"</td></tr> <tr><td>OEM</td><td>4348322</td></tr> <tr><td colspan="2">L4 2.2L, 2.5L, 2.6L, V6 3.0L Shadow, Spirit, Caravan (86-92)</td></tr> </table>	Dientes	139	Contrapeso	No	Diám Ext.	11.75"	OEM	4348322	L4 2.2L, 2.5L, 2.6L, V6 3.0L Shadow, Spirit, Caravan (86-92)		<p>AA-C409</p> 	<table border="1"> <tr><td>Dientes</td><td>139</td></tr> <tr><td>Contrapeso</td><td>No</td></tr> <tr><td>Diám Ext.</td><td>11.75"</td></tr> <tr><td>OEM</td><td>4377411</td></tr> <tr><td colspan="2">L4 156 (2.6L) Mini Van, Ram 50, Raider (86-87) (motor Mitsubishi)</td></tr> </table>	Dientes	139	Contrapeso	No	Diám Ext.	11.75"	OEM	4377411	L4 156 (2.6L) Mini Van, Ram 50, Raider (86-87) (motor Mitsubishi)	
Dientes	139																						
Contrapeso	No																						
Diám Ext.	11.75"																						
OEM	4348322																						
L4 2.2L, 2.5L, 2.6L, V6 3.0L Shadow, Spirit, Caravan (86-92)																							
Dientes	139																						
Contrapeso	No																						
Diám Ext.	11.75"																						
OEM	4377411																						
L4 156 (2.6L) Mini Van, Ram 50, Raider (86-87) (motor Mitsubishi)																							

1.1 Aros dentados transmisión automática

Automatic transmission flex plates



Chrysler / Dodge



AA-C410	
Dientes	139
Contrapeso	No
Diám Ext.	11.75"
OEM	4736190
V6 3.0L, 3.3L, 3.8L Caravan, Voyager (98-04), Intrepid V6 3.5L (1997) (turbina 90°)	

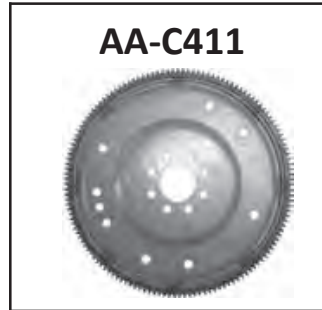

AA-C411	
Dientes	139
Contrapeso	No
Diám Ext.	11.75"
OEM	N / D
L4 2.2L, 2.5L, 2.6L, V6 3.0L Shadow, Spirit, Caravan (86-92) (conv. 3 y 4 puntos de apoyo)	



AA-C412	
Dientes	139
Contrapeso	No
Diám Ext.	11.75"
OEM	4376479
L4 135 (2.2L), Serie K (78-85) (conv. 6 tornillos de cigüeñal y 4 puntos de apoyo)	



AA-C413	
Dientes	N / A
Contrapeso	No
Diám Ext.	11.56"
OEM	53008665
V6 3.9L Pick ups Ram 1500, Ram Van 1500 (94-00)	



AA-C414	
Dientes	N / A
Contrapeso	No
Diám Ext.	11.56"
OEM	53008669
V8 5.2L, 5.9L Pick ups Ram 1500, 2500, 3500 (94-96)	



AA-C415	
Dientes	N / A
Contrapeso	Si
Diám Ext.	11.56"
OEM	4863841
V8 5.2L, 5.9L Pick ups Ram 1500, 2500, 3500 (97-04)	



AA-C416	
Dientes	N / A
Contrapeso	N / A
Diám Ext.	8.875"
OEM	23211-21054
L4 1.5L, 1.6L Dodge Verna (Hyundai Accent) (03-06)	



AA-C417	
Dientes	139
Contrapeso	No
Diám Ext.	11.75"
OEM	4736299AB
V6 2.7L, 3.5L Intrepid (00-04), V6 2.7L Stratus (05-06), V6 3.3L, 3.8L, 4.0L Caravan, Grand Caravan (04-11) V6 2.7L, 3.5L Charger (06-07), V6 3.8L Jeep Wrangler (07-11)	



AA-C418	
Dientes	N / A
Contrapeso	No
Diám Ext.	11.56"
OEM	52118255
V8 5.2L, 5.9L Pick ups Ram 1500, 2500, 3500 (96-03)	





AA-C419	
Dientes	N / A
Contrapeso	No
Diám Ext.	11.56"
OEM	52118256
V6 3.9L Pick ups Ram 1500, Dakota (96-03)	

1.1 Aros dentados transmisión automática Automatic transmission flex plates



Chrysler / Dodge

AA-C420 	Dientes	131
	Contrapeso	No
	Diám Ext.	13.20"
	OEM	04736604AA
	Jeep Liberty V6 3.7L (02-07) Dodge Dakota (00-11), Durango (99-09), Ram 1500, 2500 (02-12), Jeep Grand Cherokee (99-13) V6 3.7L, V8 4.7L, 5.7L HEMI	

AA-C421 	Dientes	139
	Contrapeso	No
	Diám Ext.	11.75"
	OEM	4736179AB
	Chrysler Concorde V6 2.7L, 3.2L (00-01) Sebring V6 2.7L (01-04), Dodge Intrepid V6 2.7L, 3.2L (97-01), 3.5L (00-01) Stratus V6 2.7L (01-04)	

AA-C422  NUEVO PRODUCTO	Dientes	131
	Contrapeso	No
	Diám Ext.	13.20"
	OEM	04752574AB
	Chrysler 300 V8 5.7L (05-16) Ram 1500, 2500 V8 5.7L (13-16) Charger V8 5.7L (06-16)	

Cummins

AA-M500 	Dientes	146
	Contrapeso	No
	Diám Ext.	14.815"
	OEM	3918957
	L4 239 (3.9L) (Cummins diesel) 4B, 4BT, 4BTA	

AA-M501  NUEVO PRODUCTO	Dientes	159
	Contrapeso	No
	Diám Ext.	16.05"
	OEM	3918959
	Cummins engine B Series 3.9L, 5.9L, 6.7L (Allison transmission)	

Ford

AA-F200 	Dientes	164
	Contrapeso	Si
	Diám Ext.	14.23"
	OEM	EOAZ-6375A
	V8 289, 302, 351W (65-85) (transmission C4 o FMX)	

AA-F201 	Dientes	164
	Contrapeso	Si
	Diám Ext.	14.23"
	OEM	D1AZ-6375A
	V8 351M, 400 (71-82) (transmisión C6)	

1.1 Aros dentados transmisión automática

Automatic transmission flex plates





Ford

	Dientes	164
	Contrapeso	No
	Diám Ext.	14.23"
	OEM	C5TZ-6375-T
	L6 240, 250, 300 (65-81) (transmisión C4 o FMX)	

	Dientes	135
	Contrapeso	No
	Diám Ext.	11.30"
	OEM	D4ZZ-6375D
	L4 140 Fairmont, Mustang y Pinto (74-80) (transmisión C3)	

	Dientes	135
	Contrapeso	No
	Diám Ext.	11.30"
	OEM	D5FZ-6375-A
	L4 140 Fairmont, Mustang y Pinto (74-80) (transmisión C4)	

	Dientes	164
	Contrapeso	Si
	Diám Ext.	14.23"
	OEM	D1ZZ-6375A
	V8 302, 351 autos y pick ups F-100, F-150 (71-94) (transmisión C6)	

	Dientes	164
	Contrapeso	Si
	Diám Ext.	14.23"
	OEM	E0SZ-6375-A
	V8 255, 302 Mustang, Thunderbird, Cougar (80-82) (transmisión AOD)	

	Dientes	164
	Contrapeso	No
	Diám Ext.	14.23"
	OEM	D5TZ-6375A
	L6 300 (4.9L) Pick ups F-100, F-150 (75-94) (transmisión C6)	

	Dientes	184
	Contrapeso	No
	Diám Ext.	15.55"
	OEM	C5AZ-6375-D
	V8 352, 360, 390, 427 autos y pick ups (65-76)	

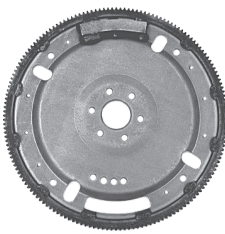
	Dientes	164
	Contrapeso	Si
	Diám Ext.	14.23"
	OEM	E2AZ-6375A
	V8 302 (5.0L) F-100, F-150, Mustang, Thunderbird, Cougar (83-95) (transmisión AOD, AODE)	

	Dientes	135
	Contrapeso	No
	Diám Ext.	11.30"
	OEM	D1FZ-6375-A
	L4 122, 140 Pinto (71-74)	









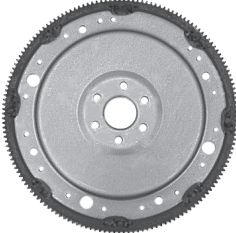

	Dientes	157
	Contrapeso	Si
	Diám Ext.	13.30"
	OEM	C3AZ-6375L
	V8 289, 302 Falcon, Maverick y Mustang (64-77) (transmisión C4 o FMX)	

1.1 Aros dentados transmisión automática

Automatic transmission flex plates



Ford

<p>AA-F212</p> 	<table border="1"> <tr><td>Dientes</td><td>157</td></tr> <tr><td>Contrapeso</td><td>No</td></tr> <tr><td>Diám Ext.</td><td>13.30"</td></tr> <tr><td>OEM</td><td>C9OZ-6375-A</td></tr> <tr><td colspan="2">L6 250 Falcon, Granada, Maverick, Mustang (69-80)</td></tr> </table>	Dientes	157	Contrapeso	No	Diám Ext.	13.30"	OEM	C9OZ-6375-A	L6 250 Falcon, Granada, Maverick, Mustang (69-80)		<p>AA-F213</p> 	<table border="1"> <tr><td>Dientes</td><td>164</td></tr> <tr><td>Contrapeso</td><td>No</td></tr> <tr><td>Diám Ext.</td><td>14.23"</td></tr> <tr><td>OEM</td><td>D1SZ-6375A</td></tr> <tr><td colspan="2">V8 429, 460 autos y pick ups (68-78)</td></tr> </table>	Dientes	164	Contrapeso	No	Diám Ext.	14.23"	OEM	D1SZ-6375A	V8 429, 460 autos y pick ups (68-78)	
Dientes	157																						
Contrapeso	No																						
Diám Ext.	13.30"																						
OEM	C9OZ-6375-A																						
L6 250 Falcon, Granada, Maverick, Mustang (69-80)																							
Dientes	164																						
Contrapeso	No																						
Diám Ext.	14.23"																						
OEM	D1SZ-6375A																						
V8 429, 460 autos y pick ups (68-78)																							
<p>AA-F214</p> 	<table border="1"> <tr><td>Dientes</td><td>N / A</td></tr> <tr><td>Contrapeso</td><td>N / A</td></tr> <tr><td>Diám Ext.</td><td>9.875"</td></tr> <tr><td>OEM</td><td>C3DZ-6375-B</td></tr> <tr><td colspan="2">L6 170, 200 (64-82) (transmisión C4)</td></tr> </table>	Dientes	N / A	Contrapeso	N / A	Diám Ext.	9.875"	OEM	C3DZ-6375-B	L6 170, 200 (64-82) (transmisión C4)		<p>AA-F215</p> 	<table border="1"> <tr><td>Dientes</td><td>164</td></tr> <tr><td>Contrapeso</td><td>Si</td></tr> <tr><td>Diám Ext.</td><td>14.23"</td></tr> <tr><td>OEM</td><td>D9TZ-6375-A</td></tr> <tr><td colspan="2">V8 460 (7.5L) pick ups (79-96) (con contrapeso)</td></tr> </table>	Dientes	164	Contrapeso	Si	Diám Ext.	14.23"	OEM	D9TZ-6375-A	V8 460 (7.5L) pick ups (79-96) (con contrapeso)	
Dientes	N / A																						
Contrapeso	N / A																						
Diám Ext.	9.875"																						
OEM	C3DZ-6375-B																						
L6 170, 200 (64-82) (transmisión C4)																							
Dientes	164																						
Contrapeso	Si																						
Diám Ext.	14.23"																						
OEM	D9TZ-6375-A																						
V8 460 (7.5L) pick ups (79-96) (con contrapeso)																							
<p>AA-F216</p> 	<table border="1"> <tr><td>Dientes</td><td>164</td></tr> <tr><td>Contrapeso</td><td>Si</td></tr> <tr><td>Diám Ext.</td><td>14.23"</td></tr> <tr><td>OEM</td><td>E3DZ-6375-B</td></tr> <tr><td colspan="2">V6 232 LTD, Mustang (83-86) (transmisión C5)</td></tr> </table>	Dientes	164	Contrapeso	Si	Diám Ext.	14.23"	OEM	E3DZ-6375-B	V6 232 LTD, Mustang (83-86) (transmisión C5)		<p>AA-F217</p> 	<table border="1"> <tr><td>Dientes</td><td>164</td></tr> <tr><td>Contrapeso</td><td>Si</td></tr> <tr><td>Diám Ext.</td><td>14.23"</td></tr> <tr><td>OEM</td><td>E3SZ-6375B</td></tr> <tr><td colspan="2">V6 232 Cougar, Thunderbird (83-87) (transmisión C5)</td></tr> </table>	Dientes	164	Contrapeso	Si	Diám Ext.	14.23"	OEM	E3SZ-6375B	V6 232 Cougar, Thunderbird (83-87) (transmisión C5)	
Dientes	164																						
Contrapeso	Si																						
Diám Ext.	14.23"																						
OEM	E3DZ-6375-B																						
V6 232 LTD, Mustang (83-86) (transmisión C5)																							
Dientes	164																						
Contrapeso	Si																						
Diám Ext.	14.23"																						
OEM	E3SZ-6375B																						
V6 232 Cougar, Thunderbird (83-87) (transmisión C5)																							
<p>AA-F218</p> 	<table border="1"> <tr><td>Dientes</td><td>164</td></tr> <tr><td>Contrapeso</td><td>Si</td></tr> <tr><td>Diám Ext.</td><td>14.23"</td></tr> <tr><td>OEM</td><td>E9SZ-6375B</td></tr> <tr><td colspan="2">V6 3.8L (232) Mustang, Thunderbird, Cougar (88-95)</td></tr> </table>	Dientes	164	Contrapeso	Si	Diám Ext.	14.23"	OEM	E9SZ-6375B	V6 3.8L (232) Mustang, Thunderbird, Cougar (88-95)		<p>AA-F219</p> 	<table border="1"> <tr><td>Dientes</td><td>138</td></tr> <tr><td>Contrapeso</td><td>No</td></tr> <tr><td>Diám Ext.</td><td>11.69"</td></tr> <tr><td>OEM</td><td>E7RY-6375B</td></tr> <tr><td colspan="2">V6 177 (88-89) (transmisión A4LD)</td></tr> </table>	Dientes	138	Contrapeso	No	Diám Ext.	11.69"	OEM	E7RY-6375B	V6 177 (88-89) (transmisión A4LD)	
Dientes	164																						
Contrapeso	Si																						
Diám Ext.	14.23"																						
OEM	E9SZ-6375B																						
V6 3.8L (232) Mustang, Thunderbird, Cougar (88-95)																							
Dientes	138																						
Contrapeso	No																						
Diám Ext.	11.69"																						
OEM	E7RY-6375B																						
V6 177 (88-89) (transmisión A4LD)																							
<p>AA-F220</p> 	<table border="1"> <tr><td>Dientes</td><td>164</td></tr> <tr><td>Contrapeso</td><td>Si</td></tr> <tr><td>Diám Ext.</td><td>14.23"</td></tr> <tr><td>OEM</td><td>E1TZ-6375C</td></tr> <tr><td colspan="2">V8 302 (5.0L) pick ups F-100, F-150 (81-96) (transmisión C6 / E4OD)</td></tr> </table>	Dientes	164	Contrapeso	Si	Diám Ext.	14.23"	OEM	E1TZ-6375C	V8 302 (5.0L) pick ups F-100, F-150 (81-96) (transmisión C6 / E4OD)		<p>AA-F221</p> 	<table border="1"> <tr><td>Dientes</td><td>135</td></tr> <tr><td>Contrapeso</td><td>No</td></tr> <tr><td>Diám Ext.</td><td>11.30"</td></tr> <tr><td>OEM</td><td>E83Z-6375A</td></tr> <tr><td colspan="2">L4 140 (2.3L), 153 (2.5L) Tempo, Taurus, Topaz; (84-94)</td></tr> </table>	Dientes	135	Contrapeso	No	Diám Ext.	11.30"	OEM	E83Z-6375A	L4 140 (2.3L), 153 (2.5L) Tempo, Taurus, Topaz; (84-94)	
Dientes	164																						
Contrapeso	Si																						
Diám Ext.	14.23"																						
OEM	E1TZ-6375C																						
V8 302 (5.0L) pick ups F-100, F-150 (81-96) (transmisión C6 / E4OD)																							
Dientes	135																						
Contrapeso	No																						
Diám Ext.	11.30"																						
OEM	E83Z-6375A																						
L4 140 (2.3L), 153 (2.5L) Tempo, Taurus, Topaz; (84-94)																							

1.1 Aros dentados transmisión automática

Automatic transmission flex plates





Ford

	AA-F222	Dientes	135
		Contrapeso	No
		Diám Ext.	11.30"
		OEM	E6DZ-6375
	V6 183 (3.0L) Taurus, Topaz (86-90)		

	AA-F223	Dientes	164
		Contrapeso	No
		Diám Ext.	14.23"
		OEM	F1AZ-6375-A
	V8 4.6L (281) Thunderbird, Cougar, Grand Marquis, Lincoln Town Car (92-95)		

	AA-F224	Dientes	164
		Contrapeso	No
		Diám Ext.	14.23"
		OEM	E3TZ-6375-G
	L6 300 (4.9L) Pick ups F-100, F-150 (83-90) (transmision C5 / AOD)		

	AA-F225	Dientes	164
		Contrapeso	Si
		Diám Ext.	14.23"
		OEM	E5SZ-6375-A
	V6 232 (3.8L) Thunderbird, Cougar (85-87) (transmisión AOD)		

	AA-F226	Dientes	184
		Contrapeso	Si
		Diám Ext.	15.55"
		OEM	C6AZ-6375-B
	V8 427, 428 autos (66-70) (transmision C6)		

	AA-F227	Dientes	132
		Contrapeso	No
		Diám Ext.	11.187"
		OEM	D8BZ-6375-B
	L6 200 Fairmont, Mustang, Thunderbird (78-81) (transmisión C3)		

	AA-F228	Dientes	164
		Contrapeso	Si
		Diám Ext.	14.23"
		OEM	E2SZ-6375-A
	V6 232 Ford LTD (83-86) (transmision AOD)		

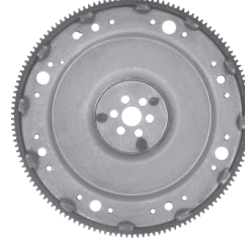
	AA-F230	Dientes	138
		Contrapeso	No
		Diám Ext.	11.69"
		OEM	D4ZZ-6375C
	V6 171 Mustang, Ranger, Bronco II (79-85) (transmisión C4)		

	AA-F231	Dientes	141
		Contrapeso	Si
		Diám Ext.	11.94"
		OEM	D5ZZ-6375-A
	V8 302 Mustang II, Mustang (75-79)		









	AA-F232	Dientes	164
		Contrapeso	Si
		Diám Ext.	14.23"
		OEM	D1ZZ-6375-C
	V8 351C (Cleveland) Mustang, Cougar, Torino (71-74)		

1.1 Aros dentados transmisión automática

Automatic transmission flex plates

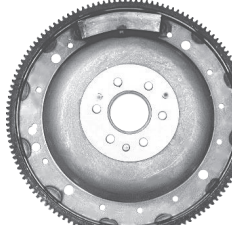
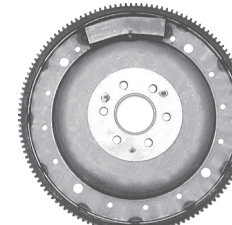

Ford

 <p>AA-F233</p>	<table border="1"> <tr><td>Dientes</td><td>135</td></tr> <tr><td>Contrapeso</td><td>No</td></tr> <tr><td>Diám Ext.</td><td>11.30"</td></tr> <tr><td>OEM</td><td>E5TZ-6375-D</td></tr> <tr><td colspan="2">L4 2.3L (140), 2.5L (153) Ranger (85-01), Mazda B2300, B2500 (94-00)</td></tr> </table>	Dientes	135	Contrapeso	No	Diám Ext.	11.30"	OEM	E5TZ-6375-D	L4 2.3L (140), 2.5L (153) Ranger (85-01), Mazda B2300, B2500 (94-00)		 <p>AA-F234</p>	<table border="1"> <tr><td>Dientes</td><td>138</td></tr> <tr><td>Contrapeso</td><td>No</td></tr> <tr><td>Diám Ext.</td><td>11.69"</td></tr> <tr><td>OEM</td><td>D5ZZ-6375-B</td></tr> <tr><td colspan="2">V6 171 Mustang II, Mustang (75-79) (transmisión C3)</td></tr> </table>	Dientes	138	Contrapeso	No	Diám Ext.	11.69"	OEM	D5ZZ-6375-B	V6 171 Mustang II, Mustang (75-79) (transmisión C3)	
Dientes	135																						
Contrapeso	No																						
Diám Ext.	11.30"																						
OEM	E5TZ-6375-D																						
L4 2.3L (140), 2.5L (153) Ranger (85-01), Mazda B2300, B2500 (94-00)																							
Dientes	138																						
Contrapeso	No																						
Diám Ext.	11.69"																						
OEM	D5ZZ-6375-B																						
V6 171 Mustang II, Mustang (75-79) (transmisión C3)																							
 <p>AA-F235</p>	<table border="1"> <tr><td>Dientes</td><td>138</td></tr> <tr><td>Contrapeso</td><td>No</td></tr> <tr><td>Diám Ext.</td><td>11.69"</td></tr> <tr><td>OEM</td><td>F1TZ-6375-A</td></tr> <tr><td colspan="2">V6 177 (2.9L), 244 (4.0L) Ranger, Explorer (86-96), Mazda B4000, Navajo (91-97)</td></tr> </table>	Dientes	138	Contrapeso	No	Diám Ext.	11.69"	OEM	F1TZ-6375-A	V6 177 (2.9L), 244 (4.0L) Ranger, Explorer (86-96), Mazda B4000, Navajo (91-97)		 <p>AA-F237</p>	<table border="1"> <tr><td>Dientes</td><td>135</td></tr> <tr><td>Contrapeso</td><td>No</td></tr> <tr><td>Diám Ext.</td><td>11.30"</td></tr> <tr><td>OEM</td><td>E63Z-6375-A</td></tr> <tr><td colspan="2">L4 153 (2.5L), Taurus, Sable (86-87)</td></tr> </table>	Dientes	135	Contrapeso	No	Diám Ext.	11.30"	OEM	E63Z-6375-A	L4 153 (2.5L), Taurus, Sable (86-87)	
Dientes	138																						
Contrapeso	No																						
Diám Ext.	11.69"																						
OEM	F1TZ-6375-A																						
V6 177 (2.9L), 244 (4.0L) Ranger, Explorer (86-96), Mazda B4000, Navajo (91-97)																							
Dientes	135																						
Contrapeso	No																						
Diám Ext.	11.30"																						
OEM	E63Z-6375-A																						
L4 153 (2.5L), Taurus, Sable (86-87)																							
 <p>AA-F238</p>	<table border="1"> <tr><td>Dientes</td><td>135</td></tr> <tr><td>Contrapeso</td><td>No</td></tr> <tr><td>Diám Ext.</td><td>11.30"</td></tr> <tr><td>OEM</td><td>E69Z-6375-A</td></tr> <tr><td colspan="2">V6 3.0L (183) Ranger (91-08) , Mazda B3000 (94-98)</td></tr> </table>	Dientes	135	Contrapeso	No	Diám Ext.	11.30"	OEM	E69Z-6375-A	V6 3.0L (183) Ranger (91-08) , Mazda B3000 (94-98)		 <p>AA-F239</p>	<table border="1"> <tr><td>Dientes</td><td>135</td></tr> <tr><td>Contrapeso</td><td>Si</td></tr> <tr><td>Diám Ext.</td><td>11.30"</td></tr> <tr><td>OEM</td><td>E8DZ-6375-A</td></tr> <tr><td colspan="2">V6 232 (3.8L) Taurus, Sable (88-89)</td></tr> </table>	Dientes	135	Contrapeso	Si	Diám Ext.	11.30"	OEM	E8DZ-6375-A	V6 232 (3.8L) Taurus, Sable (88-89)	
Dientes	135																						
Contrapeso	No																						
Diám Ext.	11.30"																						
OEM	E69Z-6375-A																						
V6 3.0L (183) Ranger (91-08) , Mazda B3000 (94-98)																							
Dientes	135																						
Contrapeso	Si																						
Diám Ext.	11.30"																						
OEM	E8DZ-6375-A																						
V6 232 (3.8L) Taurus, Sable (88-89)																							
 <p>AA-F240</p>	<table border="1"> <tr><td>Dientes</td><td>135</td></tr> <tr><td>Contrapeso</td><td>Si</td></tr> <tr><td>Diám Ext.</td><td>11.30"</td></tr> <tr><td>OEM</td><td>E9DZ-6375-B</td></tr> <tr><td colspan="2">V6 232 (3.8L) Taurus, Sable (89-90)</td></tr> </table>	Dientes	135	Contrapeso	Si	Diám Ext.	11.30"	OEM	E9DZ-6375-B	V6 232 (3.8L) Taurus, Sable (89-90)		 <p>AA-F241</p>	<table border="1"> <tr><td>Dientes</td><td>135</td></tr> <tr><td>Contrapeso</td><td>Si</td></tr> <tr><td>Diám Ext.</td><td>11.30"</td></tr> <tr><td>OEM</td><td>F1DZ-6375-C</td></tr> <tr><td colspan="2">V6 3.8L Taurus, Sable, Windstar (91-95)</td></tr> </table>	Dientes	135	Contrapeso	Si	Diám Ext.	11.30"	OEM	F1DZ-6375-C	V6 3.8L Taurus, Sable, Windstar (91-95)	
Dientes	135																						
Contrapeso	Si																						
Diám Ext.	11.30"																						
OEM	E9DZ-6375-B																						
V6 232 (3.8L) Taurus, Sable (89-90)																							
Dientes	135																						
Contrapeso	Si																						
Diám Ext.	11.30"																						
OEM	F1DZ-6375-C																						
V6 3.8L Taurus, Sable, Windstar (91-95)																							
 <p>AA-F242</p>	<table border="1"> <tr><td>Dientes</td><td>135</td></tr> <tr><td>Contrapeso</td><td>No</td></tr> <tr><td>Diám Ext.</td><td>11.30"</td></tr> <tr><td>OEM</td><td>F1DZ-6375-A</td></tr> <tr><td colspan="2">V6 3.0L Taurus, Sable (91-95)</td></tr> </table>	Dientes	135	Contrapeso	No	Diám Ext.	11.30"	OEM	F1DZ-6375-A	V6 3.0L Taurus, Sable (91-95)		 <p>AA-F243</p>	<table border="1"> <tr><td>Dientes</td><td>135</td></tr> <tr><td>Contrapeso</td><td>No</td></tr> <tr><td>Diám Ext.</td><td>11.30"</td></tr> <tr><td>OEM</td><td>F3DZ-6375-A</td></tr> <tr><td colspan="2">V6 3.2L Taurus (93-95)</td></tr> </table>	Dientes	135	Contrapeso	No	Diám Ext.	11.30"	OEM	F3DZ-6375-A	V6 3.2L Taurus (93-95)	
Dientes	135																						
Contrapeso	No																						
Diám Ext.	11.30"																						
OEM	F1DZ-6375-A																						
V6 3.0L Taurus, Sable (91-95)																							
Dientes	135																						
Contrapeso	No																						
Diám Ext.	11.30"																						
OEM	F3DZ-6375-A																						
V6 3.2L Taurus (93-95)																							

1.1 Aros dentados transmisión automática

Automatic transmission flex plates



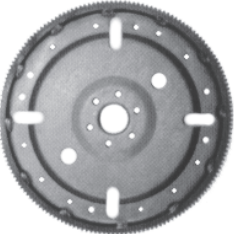

Ford

AA-F244 	Dientes	164
	Contrapeso	No
	Diám Ext.	14.23"
	OEM	E9SZ-6375-C
	V6 3.8L Thunderbird, Cougar (89-95), V6 4.2L F-150 (97-08) (transmision AODE)	

AA-F245 	Dientes	132
	Contrapeso	No
	Diám Ext.	11.187"
	OEM	E1BZ-6375-B
	L6 200 Fairmont, Mustang, Thunderbird, Cougar (81-83) (transmision C3)	

AA-F246 	Dientes	155
	Contrapeso	Si
	Diám Ext.	15.681"
	OEM	F6TZ-6375-AA
	V8 7.3L (Navistar) Super Duty F-250, F-350, F-450 (95-03) (transmision E4OD)	

AA-F247 	Dientes	135
	Contrapeso	No
	Diám Ext.	11.88"
	OEM	F5DZ-6375-A
	V6 3.0L Windstar (95-00)	

AA-F248 	Dientes	138
	Contrapeso	No
	Diám Ext.	11.69"
	OEM	F5RZ-6375-C
	V6 2.5L DOHC Contour, Mystique (95-00)	

AA-F249 	Dientes	164
	Contrapeso	No
	Diám Ext.	14.23"
	OEM	F6AZ-6375-DA
	V8 4.6L F-150, F-250, Lobo, (97-02) (8 agujeros cigüeñal) (transmision 4R70W)	

AA-F250 	Dientes	164
	Contrapeso	No
	Diám Ext.	14.23"
	OEM	E3TZ-6375-G
	L6 300 (4.9L) F-100, F-150 (83-91) (transmision C5 / AOD)	

AA-F251 	Dientes	164
	Contrapeso	No
	Diám Ext.	14.23"
	OEM	F6AZ-6375-BA
	V8 4.6L Crown Victoria (96-08), F-150, Expedition (97-04) (6 agujeros cigüeñal)	

AA-F252 	Dientes	164
	Contrapeso	No
	Diám Ext.	14.13"
	OEM	1C3Z-6375-BA
	V8 5.4L F-150, F-250, Lobo (97-02) (transmision E4OD / 4R100)	











AA-F253 	Dientes	135
	Contrapeso	No
	Diám Ext.	11.300"
	OEM	F6DZ-6375-A
	V6 3.0L DOHC Taurus, Sable (96-05)	

1.1 Aros dentados transmisión automática

Automatic transmission flex plates



Ford

 <p>AA-F254</p>	<table border="1"> <tr><td>Dientes</td><td>138</td></tr> <tr><td>Contrapeso</td><td>No</td></tr> <tr><td>Diám Ext.</td><td>11.655"</td></tr> <tr><td>OEM</td><td>F77Z-6375-AA</td></tr> <tr><td colspan="2">V6 4.0L Ranger, Explorer (97-02)</td></tr> </table>	Dientes	138	Contrapeso	No	Diám Ext.	11.655"	OEM	F77Z-6375-AA	V6 4.0L Ranger, Explorer (97-02)		 <p>AA-F255</p>	<table border="1"> <tr><td>Dientes</td><td>164</td></tr> <tr><td>Contrapeso</td><td>No</td></tr> <tr><td>Diám Ext.</td><td>14.23"</td></tr> <tr><td>OEM</td><td>4C3Z-6375-AA</td></tr> <tr><td colspan="2">V8 5.4L (24 val.) Lobo, F-150, F-250, F-350 (05-10)</td></tr> </table>	Dientes	164	Contrapeso	No	Diám Ext.	14.23"	OEM	4C3Z-6375-AA	V8 5.4L (24 val.) Lobo, F-150, F-250, F-350 (05-10)	
Dientes	138																						
Contrapeso	No																						
Diám Ext.	11.655"																						
OEM	F77Z-6375-AA																						
V6 4.0L Ranger, Explorer (97-02)																							
Dientes	164																						
Contrapeso	No																						
Diám Ext.	14.23"																						
OEM	4C3Z-6375-AA																						
V8 5.4L (24 val.) Lobo, F-150, F-250, F-350 (05-10)																							
 <p>AA-F256</p>	<table border="1"> <tr><td>Dientes</td><td>135</td></tr> <tr><td>Contrapeso</td><td>No</td></tr> <tr><td>Diám Ext.</td><td>11.88"</td></tr> <tr><td>OEM</td><td>1F2Z-6375-CA</td></tr> <tr><td colspan="2">V6 3.8L Windstar (01-03), V6 3.9L, 4.2L Freestar (04-07)</td></tr> </table>	Dientes	135	Contrapeso	No	Diám Ext.	11.88"	OEM	1F2Z-6375-CA	V6 3.8L Windstar (01-03), V6 3.9L, 4.2L Freestar (04-07)		 <p>AA-F257</p>	<table border="1"> <tr><td>Dientes</td><td>164</td></tr> <tr><td>Contrapeso</td><td>Si</td></tr> <tr><td>Diám Ext.</td><td>14.23"</td></tr> <tr><td>OEM</td><td>E3DZ-6375-A</td></tr> <tr><td colspan="2">V6 232 LTD (1984) (transmission AOD)</td></tr> </table>	Dientes	164	Contrapeso	Si	Diám Ext.	14.23"	OEM	E3DZ-6375-A	V6 232 LTD (1984) (transmission AOD)	
Dientes	135																						
Contrapeso	No																						
Diám Ext.	11.88"																						
OEM	1F2Z-6375-CA																						
V6 3.8L Windstar (01-03), V6 3.9L, 4.2L Freestar (04-07)																							
Dientes	164																						
Contrapeso	Si																						
Diám Ext.	14.23"																						
OEM	E3DZ-6375-A																						
V6 232 LTD (1984) (transmission AOD)																							
 <p>AA-F258</p>	<table border="1"> <tr><td>Dientes</td><td>135</td></tr> <tr><td>Contrapeso</td><td>No</td></tr> <tr><td>Diám Ext.</td><td>11.29"</td></tr> <tr><td>OEM</td><td>E2FZ-6375-A</td></tr> <tr><td colspan="2">L4 1.6L Escort (81-83)</td></tr> </table>	Dientes	135	Contrapeso	No	Diám Ext.	11.29"	OEM	E2FZ-6375-A	L4 1.6L Escort (81-83)		 <p>AA-F259</p>	<table border="1"> <tr><td>Dientes</td><td>112</td></tr> <tr><td>Contrapeso</td><td>No</td></tr> <tr><td>Diám Ext.</td><td>11.38"</td></tr> <tr><td>OEM</td><td>F42Z-6375-A</td></tr> <tr><td colspan="2">L4 2.0L DOHC Probe (94-97)</td></tr> </table>	Dientes	112	Contrapeso	No	Diám Ext.	11.38"	OEM	F42Z-6375-A	L4 2.0L DOHC Probe (94-97)	
Dientes	135																						
Contrapeso	No																						
Diám Ext.	11.29"																						
OEM	E2FZ-6375-A																						
L4 1.6L Escort (81-83)																							
Dientes	112																						
Contrapeso	No																						
Diám Ext.	11.38"																						
OEM	F42Z-6375-A																						
L4 2.0L DOHC Probe (94-97)																							
 <p>AA-F260</p>	<table border="1"> <tr><td>Dientes</td><td>135</td></tr> <tr><td>Contrapeso</td><td>No</td></tr> <tr><td>Diám Ext.</td><td>11.88"</td></tr> <tr><td>OEM</td><td>F5OY-6375-A</td></tr> <tr><td colspan="2">V8 4.6L Lincoln Continental (98-02) (transmission AX4N)</td></tr> </table>	Dientes	135	Contrapeso	No	Diám Ext.	11.88"	OEM	F5OY-6375-A	V8 4.6L Lincoln Continental (98-02) (transmission AX4N)		 <p>AA-F261</p>	<table border="1"> <tr><td>Dientes</td><td>155</td></tr> <tr><td>Contrapeso</td><td>Si</td></tr> <tr><td>Diám Ext.</td><td>15.63"</td></tr> <tr><td>OEM</td><td>E9TZ-6375-A</td></tr> <tr><td colspan="2">V8 7.3L (Navistar) F-250, F-350, F-450 (88-91)</td></tr> </table>	Dientes	155	Contrapeso	Si	Diám Ext.	15.63"	OEM	E9TZ-6375-A	V8 7.3L (Navistar) F-250, F-350, F-450 (88-91)	
Dientes	135																						
Contrapeso	No																						
Diám Ext.	11.88"																						
OEM	F5OY-6375-A																						
V8 4.6L Lincoln Continental (98-02) (transmission AX4N)																							
Dientes	155																						
Contrapeso	Si																						
Diám Ext.	15.63"																						
OEM	E9TZ-6375-A																						
V8 7.3L (Navistar) F-250, F-350, F-450 (88-91)																							
 <p>AA-F262</p>	<table border="1"> <tr><td>Dientes</td><td>135</td></tr> <tr><td>Contrapeso</td><td>No</td></tr> <tr><td>Diám Ext.</td><td>11.25"</td></tr> <tr><td>OEM</td><td>F6DZ-6375-AB</td></tr> <tr><td colspan="2">V6 3.4L Taurus (96-99)</td></tr> </table>	Dientes	135	Contrapeso	No	Diám Ext.	11.25"	OEM	F6DZ-6375-AB	V6 3.4L Taurus (96-99)		 <p>AA-F263</p>	<table border="1"> <tr><td>Dientes</td><td>164</td></tr> <tr><td>Contrapeso</td><td>Si</td></tr> <tr><td>Diám Ext.</td><td>14.23"</td></tr> <tr><td>OEM</td><td>XR3Z-6375-CA</td></tr> <tr><td colspan="2">V6 3.8L Mustang (98-04)</td></tr> </table>	Dientes	164	Contrapeso	Si	Diám Ext.	14.23"	OEM	XR3Z-6375-CA	V6 3.8L Mustang (98-04)	
Dientes	135																						
Contrapeso	No																						
Diám Ext.	11.25"																						
OEM	F6DZ-6375-AB																						
V6 3.4L Taurus (96-99)																							
Dientes	164																						
Contrapeso	Si																						
Diám Ext.	14.23"																						
OEM	XR3Z-6375-CA																						
V6 3.8L Mustang (98-04)																							

1.1 Aros dentados transmisión automática

Automatic transmission flex plates





Ford

AA-F264 	Dientes	132
	Contrapeso	Si
	Diám Ext.	11.25"
	OEM	FO2Z-6375-A
	L4 2.2L, V6 3.0L Probe (90-92)	

AA-F265 	Dientes	135
	Contrapeso	No
	Diám Ext.	11.25"
	OEM	1L2Z-6375-CA
	V6 4.0L Explorer, Mercury Mountainer (03-10)	

AA-F266 	Dientes	164
	Contrapeso	No
	Diám Ext.	14.23"
	OEM	4W7Z-6375-AA
	V8 4.6L F-150, F-250 Heritage (97-08), Mustang (96-04) (transmisión 4R70W / 4R75W)	

AA-F267 	Dientes	155
	Contrapeso	No
	Diám Ext.	15.68"
	OEM	F3TZ-6375-B
	V8 7.3L (Navistar) F-250, F-350, F-450 (92-96)	

AA-F268 	Dientes	164
	Contrapeso	No
	Diám Ext.	14.23"
	OEM	BL3Z-6375-A
	V6 3.5L, 3.7L, V8 5.0L F-150, Mustang (11-14)	

AA-F269 	Dientes	135
	Contrapeso	No
	Diám Ext.	11.25"
	OEM	F8CZ-6375-AA
	L4 2.0L DOHC Escort ZX2 (98-03), Contour, Mystique (95-00), Focus (00-04)	

AA-F270  <small>NUEVO PRODUCTO</small>	Dientes	141
	Contrapeso	Si
	Diám Ext.	14.28"
	OEM	3C3Z-6375-AA
	Ford F-250, F-350, F-450, F-550 Super Duty motores diesel V8 6.0L (03-07), V8 6.4L (08-10)	

AA-F271  <small>NUEVO PRODUCTO</small>	Dientes	112
	Contrapeso	No
	Diám Ext.	11.36"
	OEM	1S7Z-6375-C
	Focus 2.0L (05-07), 2.3L (03-06), Fusion 2.5L (10-15), 2.0L Ecoboost (13-15) Escape 2.0L Ecoboost (13-15) 2.3L (05-08), 2.5L (09-15)	

AA-F272  <small>NUEVO PRODUCTO</small>	Dientes	138
	Contrapeso	No
	Diám Ext.	11.65"
	OEM	YL8Z-6375-AA
	Escape 2.0L Zetec (01-04), V6 3.0L (01-08), Mercury Mariner V6 3.0L (05-08)	







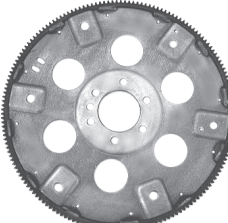
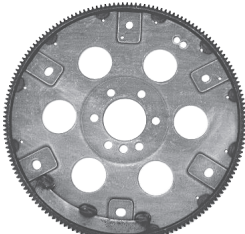

AA-F273  <small>NUEVO PRODUCTO</small>	Dientes	141
	Contrapeso	Si
	Diám Ext.	14.28"
	OEM	8C3Z-6375-A
	Ford F-250, F-350, F-450 V8 6.4L diesel (08-10)	

1.1 Aros dentados transmisión automática

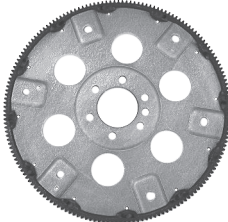
Automatic transmission flex plates

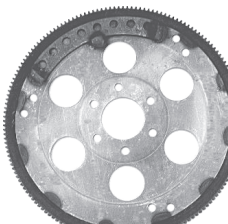

General Motors

 <p>AA-G100</p>	<table border="1"> <tr><td>Dientes</td><td>168</td></tr> <tr><td>Contrapeso</td><td>No</td></tr> <tr><td>Diám Ext.</td><td>14.13"</td></tr> <tr><td>OEM</td><td>340296</td></tr> </table>	Dientes	168	Contrapeso	No	Diám Ext.	14.13"	OEM	340296	<p>L6 250, V8 283, 305, 307, 350, 396, 402, 427 (66-81)</p>	 <p>AA-G101</p>	<table border="1"> <tr><td>Dientes</td><td>168</td></tr> <tr><td>Contrapeso</td><td>Si</td></tr> <tr><td>Diám Ext.</td><td>14.13"</td></tr> <tr><td>OEM</td><td>340298</td></tr> </table>	Dientes	168	Contrapeso	Si	Diám Ext.	14.13"	OEM	340298	<p>V8 400 (small block) Chevrolet, GMC (70-80)</p>
	Dientes	168																			
Contrapeso	No																				
Diám Ext.	14.13"																				
OEM	340296																				
Dientes	168																				
Contrapeso	Si																				
Diám Ext.	14.13"																				
OEM	340298																				
<table border="1"> <tr><td>Dientes</td><td>168</td></tr> <tr><td>Contrapeso</td><td>Si</td></tr> <tr><td>Diám Ext.</td><td>14.13"</td></tr> <tr><td>OEM</td><td>343738</td></tr> </table>	Dientes	168	Contrapeso	Si	Diám Ext.	14.13"	OEM	343738	<table border="1"> <tr><td>Dientes</td><td>153</td></tr> <tr><td>Contrapeso</td><td>No</td></tr> <tr><td>Diám Ext.</td><td>12.85"</td></tr> <tr><td>OEM</td><td>471591</td></tr> </table>	Dientes	153	Contrapeso	No	Diám Ext.	12.85"	OEM	471591				
Dientes	168																				
Contrapeso	Si																				
Diám Ext.	14.13"																				
OEM	343738																				
Dientes	153																				
Contrapeso	No																				
Diám Ext.	12.85"																				
OEM	471591																				
 <p>AA-G102</p>	<table border="1"> <tr><td>Dientes</td><td>168</td></tr> <tr><td>Contrapeso</td><td>Si</td></tr> <tr><td>Diám Ext.</td><td>14.13"</td></tr> <tr><td>OEM</td><td>343738</td></tr> </table>	Dientes	168	Contrapeso	Si	Diám Ext.	14.13"	OEM	343738	<p>V8 454 (70-76)</p>	 <p>AA-G103</p>	<table border="1"> <tr><td>Dientes</td><td>166</td></tr> <tr><td>Contrapeso</td><td>Si</td></tr> <tr><td>Diám Ext.</td><td>13.91"</td></tr> <tr><td>OEM</td><td>560712</td></tr> </table>	Dientes	166	Contrapeso	Si	Diám Ext.	13.91"	OEM	560712	<p>V8 260, 350, 403, 455 Oldsmobile, Pontiac (68-78)</p>
	Dientes	168																			
Contrapeso	Si																				
Diám Ext.	14.13"																				
OEM	343738																				
Dientes	166																				
Contrapeso	Si																				
Diám Ext.	13.91"																				
OEM	560712																				
<table border="1"> <tr><td>Dientes</td><td>160</td></tr> <tr><td>Contrapeso</td><td>No</td></tr> <tr><td>Diám Ext.</td><td>13.42"</td></tr> <tr><td>OEM</td><td>1255728</td></tr> </table>	Dientes	160	Contrapeso	No	Diám Ext.	13.42"	OEM	1255728	<table border="1"> <tr><td>Dientes</td><td>160</td></tr> <tr><td>Contrapeso</td><td>Si</td></tr> <tr><td>Diám Ext.</td><td>13.42"</td></tr> <tr><td>OEM</td><td>1262989</td></tr> </table>	Dientes	160	Contrapeso	Si	Diám Ext.	13.42"	OEM	1262989				
Dientes	160																				
Contrapeso	No																				
Diám Ext.	13.42"																				
OEM	1255728																				
Dientes	160																				
Contrapeso	Si																				
Diám Ext.	13.42"																				
OEM	1262989																				
 <p>AA-G104</p>	<table border="1"> <tr><td>Dientes</td><td>168</td></tr> <tr><td>Contrapeso</td><td>No</td></tr> <tr><td>Diám Ext.</td><td>14.13"</td></tr> <tr><td>OEM</td><td>471598</td></tr> </table>	Dientes	168	Contrapeso	No	Diám Ext.	14.13"	OEM	471598	<p>L6 250, V8 283, 305, 307, 350, 396, 402, 427 (66-81)</p>	 <p>AA-G105</p>	<table border="1"> <tr><td>Dientes</td><td>160</td></tr> <tr><td>Contrapeso</td><td>Si</td></tr> <tr><td>Diám Ext.</td><td>13.42"</td></tr> <tr><td>OEM</td><td>1262989</td></tr> </table>	Dientes	160	Contrapeso	Si	Diám Ext.	13.42"	OEM	1262989	<p>V8 300, 340, 350 (65-81) (motor Buick)</p>
	Dientes	168																			
Contrapeso	No																				
Diám Ext.	14.13"																				
OEM	471598																				
Dientes	160																				
Contrapeso	Si																				
Diám Ext.	13.42"																				
OEM	1262989																				
<table border="1"> <tr><td>Dientes</td><td>160</td></tr> <tr><td>Contrapeso</td><td>No</td></tr> <tr><td>Diám Ext.</td><td>13.42"</td></tr> <tr><td>OEM</td><td>1255728</td></tr> </table>	Dientes	160	Contrapeso	No	Diám Ext.	13.42"	OEM	1255728	<table border="1"> <tr><td>Dientes</td><td>135</td></tr> <tr><td>Contrapeso</td><td>Si</td></tr> <tr><td>Diám Ext.</td><td>13.71</td></tr> <tr><td>OEM</td><td>22500808</td></tr> </table>	Dientes	135	Contrapeso	Si	Diám Ext.	13.71	OEM	22500808				
Dientes	160																				
Contrapeso	No																				
Diám Ext.	13.42"																				
OEM	1255728																				
Dientes	135																				
Contrapeso	Si																				
Diám Ext.	13.71																				
OEM	22500808																				
 <p>AA-G106</p>	<table border="1"> <tr><td>Dientes</td><td>160</td></tr> <tr><td>Contrapeso</td><td>No</td></tr> <tr><td>Diám Ext.</td><td>13.42"</td></tr> <tr><td>OEM</td><td>1255728</td></tr> </table>	Dientes	160	Contrapeso	No	Diám Ext.	13.42"	OEM	1255728	<p>V6 231 Buick, Oldsmobile (75-77)</p>	 <p>AA-G107</p>	<table border="1"> <tr><td>Dientes</td><td>135</td></tr> <tr><td>Contrapeso</td><td>Si</td></tr> <tr><td>Diám Ext.</td><td>13.71</td></tr> <tr><td>OEM</td><td>22500808</td></tr> </table>	Dientes	135	Contrapeso	Si	Diám Ext.	13.71	OEM	22500808	<p>V8 260, 350 (78-85) (motor Oldsmobile diesel)</p>
	Dientes	160																			
Contrapeso	No																				
Diám Ext.	13.42"																				
OEM	1255728																				
Dientes	135																				
Contrapeso	Si																				
Diám Ext.	13.71																				
OEM	22500808																				
<table border="1"> <tr><td>Dientes</td><td>166</td></tr> <tr><td>Contrapeso</td><td>Si</td></tr> <tr><td>Diám Ext.</td><td>13.91"</td></tr> <tr><td>OEM</td><td>22500807</td></tr> </table>	Dientes	166	Contrapeso	Si	Diám Ext.	13.91"	OEM	22500807	<table border="1"> <tr><td>Dientes</td><td>166</td></tr> <tr><td>Contrapeso</td><td>Si</td></tr> <tr><td>Diám Ext.</td><td>13.91"</td></tr> <tr><td>OEM</td><td>22500807</td></tr> </table>	Dientes	166	Contrapeso	Si	Diám Ext.	13.91"	OEM	22500807				
Dientes	166																				
Contrapeso	Si																				
Diám Ext.	13.91"																				
OEM	22500807																				
Dientes	166																				
Contrapeso	Si																				
Diám Ext.	13.91"																				
OEM	22500807																				
 <p>AA-G108</p>	<table border="1"> <tr><td>Dientes</td><td>166</td></tr> <tr><td>Contrapeso</td><td>Si</td></tr> <tr><td>Diám Ext.</td><td>13.91"</td></tr> <tr><td>OEM</td><td>22500807</td></tr> </table>	Dientes	166	Contrapeso	Si	Diám Ext.	13.91"	OEM	22500807	<p>V8 260, 307, 350, 403 (79-90) (motor Oldsmobile)</p>	 <p>AA-G109</p>	<table border="1"> <tr><td>Dientes</td><td>135</td></tr> <tr><td>Contrapeso</td><td>Si</td></tr> <tr><td>Diám Ext.</td><td>13.71</td></tr> <tr><td>OEM</td><td>22500808</td></tr> </table>	Dientes	135	Contrapeso	Si	Diám Ext.	13.71	OEM	22500808	<p>V8 260, 350 (78-85) (motor Oldsmobile diesel)</p>
	Dientes	166																			
Contrapeso	Si																				
Diám Ext.	13.91"																				
OEM	22500807																				
Dientes	135																				
Contrapeso	Si																				
Diám Ext.	13.71																				
OEM	22500808																				
<table border="1"> <tr><td>Dientes</td><td>166</td></tr> <tr><td>Contrapeso</td><td>Si</td></tr> <tr><td>Diám Ext.</td><td>13.91"</td></tr> <tr><td>OEM</td><td>22500807</td></tr> </table>	Dientes	166	Contrapeso	Si	Diám Ext.	13.91"	OEM	22500807	<table border="1"> <tr><td>Dientes</td><td>135</td></tr> <tr><td>Contrapeso</td><td>Si</td></tr> <tr><td>Diám Ext.</td><td>13.71</td></tr> <tr><td>OEM</td><td>22500808</td></tr> </table>	Dientes	135	Contrapeso	Si	Diám Ext.	13.71	OEM	22500808				
Dientes	166																				
Contrapeso	Si																				
Diám Ext.	13.91"																				
OEM	22500807																				
Dientes	135																				
Contrapeso	Si																				
Diám Ext.	13.71																				
OEM	22500808																				

1.1 Aros dentados transmisión automática

Automatic transmission flex plates





General Motors

AA-G110 	Dientes	168
	Contrapeso	No
	Diám Ext.	14.13"
	OEM	361950
	V8 283, 307, 350, 396, 427 (65-78) (transmision TH400)	

AA-G111 	Dientes	153
	Contrapeso	No
	Diám Ext.	12.85"
	OEM	471529
	V6 220, 229, 262, L6 250, V8 262, 267, 305, 350 (79-85)	

AA-G112 	Dientes	166
	Contrapeso	No
	Diám Ext.	13.96"
	OEM	487651
	V8 326, 350, 389, 400, 421, 428, 455 (65-76) (motor Pontiac)	

AA-G113 	Dientes	142
	Contrapeso	No
	Diám Ext.	11.95"
	OEM	10031262
	L4 151 Buick, Chevrolet, Oldsmobile, Pontiac (80-92)	

AA-G114 	Dientes	166
	Contrapeso	Si
	Diám Ext.	13.96"
	OEM	10005639
	V8 301 Pontiac (77-78)	

AA-G115 	Dientes	166
	Contrapeso	Si
	Diám Ext.	13.96"
	OEM	10009275
	V8 265, 301 Buick, Pontiac (79-81) (Contrapeso grueso)	

AA-G116 	Dientes	166
	Contrapeso	No
	Diám Ext.	13.96"
	OEM	10005640
	V8 350, 400 Pontiac (76-78)	

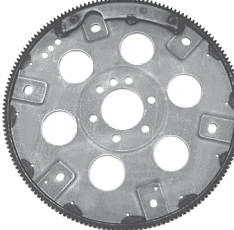
AA-G117 	Dientes	168
	Contrapeso	Si
	Diám Ext.	14.13"
	OEM	14001992
	V8 454 Chevrolet, GMC (73-90)	

AA-G118 	Dientes	168
	Contrapeso	No
	Diám Ext.	14.13"
	OEM	562949
	V8 350 Chevrolet, GMC (79-85) (transmisión TH400)	

AA-G119 	Dientes	168
	Contrapeso	Si
	Diám Ext.	14.13"
	OEM	336717
	V8 454 Chevrolet, GMC (70-78)	

1.1 Aros dentados transmisión automática Automatic transmission flex plates





General Motors

AA-G120 	Dientes	162
	Contrapeso	Si
	Diám Ext.	13.65"
	OEM	562949
	V8 307, 350 Buick, Cadillac, Oldsmobile (79-85) (motor Oldsmobile)	

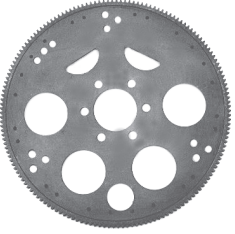
AA-G121 	Dientes	166
	Contrapeso	No
	Diám Ext.	13.96"
	OEM	1616534
	V8 368, 425, 472, 500, Cadillac (68-84)	

AA-G122 	Dientes	160
	Contrapeso	No
	Diám Ext.	13.42"
	OEM	1257040
	V6 196 Buick, Chevrolet (1978)	

AA-G123 	Dientes	160
	Contrapeso	No
	Diám Ext.	13.42"
	OEM	1257041
	V6 231 Buick, Chevrolet, Oldsmobile, Pontiac (77-78)	

AA-G124 	Dientes	160
	Contrapeso	No
	Diám Ext.	13.42"
	OEM	25501867
	V6 231, 252 Buick, Chevrolet, Cadillac, Oldsmobile, Pontiac (77-80)	

AA-G125 	Dientes	160
	Contrapeso	No
	Diám Ext.	13.42"
	OEM	25501868
	V6 231 Buick, Chevrolet (79-80)	

AA-G126 	Dientes	160
	Contrapeso	No
	Diám Ext.	13.42"
	OEM	25501869
	V6 196 Buick, Chevrolet (1979)	

AA-G127 	Dientes	162
	Contrapeso	No
	Diám Ext.	13.63"
	OEM	25501870
	V6 231 Buick (79-80)	

AA-G128 	Dientes	160
	Contrapeso	No
	Diám Ext.	13.42"
	OEM	25512346
	V6 231 Buick, Chevrolet, Oldsmobile, Pontiac (80-83)	

AA-G129 	Dientes	162
	Contrapeso	No
	Diám Ext.	13.63"
	OEM	25512347
	V6 231 Buick (81-85)	

1.1 Aros dentados transmisión automática

Automatic transmission flex plates





General Motors

AA-G130 	Dientes	160
	Contrapeso	No
	Diám Ext.	13.42"
	OEM	25512348
	V6 231, 252 Buick, Chevrolet, Cadillac, Oldsmobile, Pontiac (81-87)	

AA-G131 	Dientes	162
	Contrapeso	No
	Diám Ext.	13.63"
	OEM	25512349
	V6 252 Buick, Cadillac, Oldsmobile (81-84)	

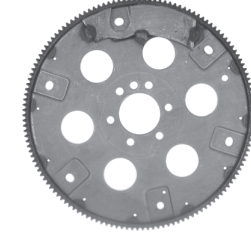
AA-G132 	Dientes	160
	Contrapeso	No
	Diám Ext.	13.42"
	OEM	25512350
	V6 231 Buick, Chevrolet (81-87)	

AA-G133 	Dientes	139
	Contrapeso	Si
	Diám Ext.	14.13"
	OEM	14077157
	V8 379 (6.2L), 395 (6.5L) diesel Chevrolet, GMC, Hummer (82-03) (transmisión TH400 / 4L80E)	

AA-G134 	Dientes	139
	Contrapeso	Si
	Diám Ext.	14.13"
	OEM	14077158
	V8 379 (6.2L), 395 (6.5L) diesel Chevrolet, GMC, Hummer (82-95) (transmisión TH700 / 4L60E)	

AA-G135 	Dientes	142
	Contrapeso	No
	Diám Ext.	11.98"
	OEM	14001182
	L4 98 Chevrolet Chevette, Pontiac T1000 (79-87)	

AA-G136 	Dientes	142
	Contrapeso	No
	Diám Ext.	11.87"
	OEM	14018713
	L4 2.0L (122), 2.2L (134), V6 2.8L (173), 3.1L (189), 3.4L (207) Buick, Chevrolet, Isuzu, Oldsmobile, Pontiac (82-96)	

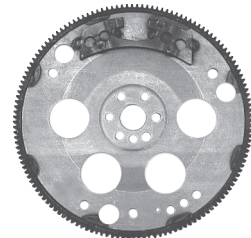
AA-G137 	Dientes	142
	Contrapeso	Si
	Diám Ext.	11.87"
	OEM	14085471
	V6 173 Buick, Cadillac, Chevrolet, Oldsmobile, Pontiac (82-87)	

AA-G138 	Dientes	168
	Contrapeso	No
	Diám Ext.	14.13"
	OEM	361051
	L6 292 Chevrolet pick ups (75-78) (transmisión TH350)	

AA-G139 	Dientes	168
	Contrapeso	No
	Diám Ext.	14.13"
	OEM	361052
	L6 292 Chevrolet pick ups (67-78) (transmisión TH400)	

1.1 Aros dentados transmisión automática

Automatic transmission flex plates



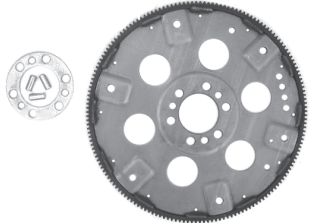

General Motors

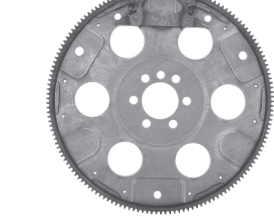
	AA-G140	Dientes	168
		Contrapeso	No
		Diám Ext.	14.13"
		OEM	14002590
	L6 292 Chevrolet pick ups (79-89) (transmisión TH400)		

	AA-G141	Dientes	153
		Contrapeso	Si
		Diám Ext.	12.85"
		OEM	14088765
	V6 4.3L (262), V8 5.0L (305), 5.7L (350) autos Buick, Cadillac, Chevrolet, Oldsmobile, Pontiac (86-97)		

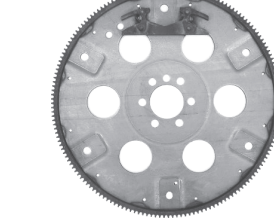
	AA-G142	Dientes	168
		Contrapeso	Si
		Diám Ext.	14.13"
		OEM	14088761
	V6 4.3L (262), V8 5.0L (305), 5.7L (350) Pick ups Chevrolet, GMC, Express 1500 (86-02), Isuzu Hombre (96-98) (transmisión TH700 / 4L60E)		

	AA-G143	Dientes	168
		Contrapeso	Si
		Diám Ext.	14.13"
		OEM	14088767
	V6 4.3L (262), V8 5.0L (305), 5.7L (350) Pick ups Chevrolet, GMC, Express 1500 (86-02) (transmisión 4L80 / 4L80E)		

	AA-G144	Dientes	142
		Contrapeso	No
		Diám Ext.	11.87"
		OEM	10004282
	L4 151 Buick, Chevrolet, Oldsmobile, Pontiac (80-81)		

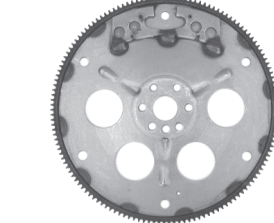
	AA-G145	Dientes	142
		Contrapeso	Si
		Diám Ext.	11.87"
		OEM	14033245
	V6 173 Buick, Chevrolet, Oldsmobile, Pontiac (80-81)		

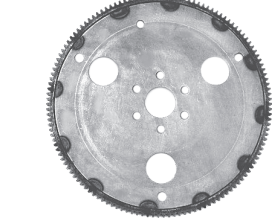
	AA-G146	Dientes	135
		Contrapeso	No
		Diám Ext.	11.375"
		OEM	10018740
	112 (1.8L), 122 (2.0L) Buick, Oldsmobile, Pontiac (82-94)		

	AA-G147	Dientes	148
		Contrapeso	Si
		Diám Ext.	12.40"
		OEM	14085472
	V6 173 Pick up S-10, S-15 (83-87), Camaro (82-87)		

	AA-G148	Dientes	148
		Contrapeso	No
		Diám Ext.	12.40"
		OEM	10044373
	L4 151 (2.5L) Pick up S-10, S-15 (85-93)		

	AA-G149	Dientes	148
		Contrapeso	No
		Diám Ext.	12.40"
		OEM	14100557
	V6 173 (2.8L), 189 (3.1L) Pick up S-10, S-15 (88-93), Camaro (88-92)		

1.1 Aros dentados transmisión automática

Automatic transmission flex plates

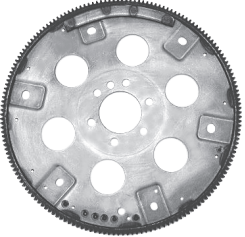

General Motors

	AA-G150	Dientes	168
		Contrapeso	Si
		Diám Ext.	14.13"
		OEM	340298
	V8 400 (small block) Chevrolet, GMC (70-80)		

	AA-G151	Dientes	162
		Contrapeso	No
		Diám Ext.	13.63"
		OEM	1623936
	V8 252 Cadillac DeVille, El Dorado, Seville (82-85)		

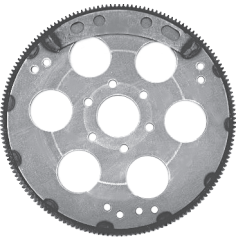
	AA-G152	Dientes	166
		Contrapeso	Si
		Diám Ext.	14.00"
		OEM	1233837
	V8 455 Buick Riviera, Electra (70-76)		

	AA-G153	Dientes	153
		Contrapeso	No
		Diám Ext.	12.93"
		OEM	10006988
	L4 151 Chevrolet, Oldsmobile, Pontiac (77-79)		

	AA-G154	Dientes	153
		Contrapeso	No
		Diám Ext.	12.93"
		OEM	10004033
	L4 151 Chevrolet, Oldsmobile, Pontiac (78-80)		

	AA-G155	Dientes	135
		Contrapeso	No
		Diám Ext.	11.375"
		OEM	14076414
	L4 122 (2.0L) Pontiac Grand Am (87-89), Lemans (89-90)		

	AA-G156	Dientes	162
		Contrapeso	No
		Diám Ext.	13.63"
		OEM	1618098
	V8 368 Cadillac El Dorado, Seville (80-81)		

	AA-G157	Dientes	168
		Contrapeso	Si
		Diám Ext.	14.13"
		OEM	10101170
	V8 7.4L (454) Pick up C1500, C2500, C3500, Suburban (91-00)		

	AA-G158	Dientes	142
		Contrapeso	Si
		Diám Ext.	11.91"
		OEM	25535388
	V6 3.3L (204) Buick Century, Cutlass Ciera (89-90)		











	AA-G159	Dientes	142
		Contrapeso	Si
		Diám Ext.	11.91"
		OEM	25534065
	V6 3.8L (231) Buick Electra, Riviera, Delta 88, Bonneville (88-90)		

1.1 Aros dentados transmisión automática

Automatic transmission flex plates



General Motors

 <p>AA-G160</p>	<table border="1"> <tr><td>Dientes</td><td>142</td></tr> <tr><td>Contrapeso</td><td>Si</td></tr> <tr><td>Diám Ext.</td><td>11.91"</td></tr> <tr><td>OEM</td><td>25517709</td></tr> </table>	Dientes	142	Contrapeso	Si	Diám Ext.	11.91"	OEM	25517709	 <p>AA-G161</p>	<table border="1"> <tr><td>Dientes</td><td>142</td></tr> <tr><td>Contrapeso</td><td>Si</td></tr> <tr><td>Diám Ext.</td><td>11.91"</td></tr> <tr><td>OEM</td><td>25512172</td></tr> </table>	Dientes	142	Contrapeso	Si	Diám Ext.	11.91"	OEM	25512172
	Dientes	142																	
Contrapeso	Si																		
Diám Ext.	11.91"																		
OEM	25517709																		
Dientes	142																		
Contrapeso	Si																		
Diám Ext.	11.91"																		
OEM	25512172																		
<p>V6 181 (3.0L) Buick Century, Cutlass Ciera (83-85)</p>		<p>V6 181 (3.0L) Buick Century, Cutlass Ciera (82-83)</p>																	
 <p>AA-G162</p>	<table border="1"> <tr><td>Dientes</td><td>142</td></tr> <tr><td>Contrapeso</td><td>Si</td></tr> <tr><td>Diám Ext.</td><td>11.91"</td></tr> <tr><td>OEM</td><td>25523510</td></tr> </table>	Dientes	142	Contrapeso	Si	Diám Ext.	11.91"	OEM	25523510	 <p>AA-G163</p>	<table border="1"> <tr><td>Dientes</td><td>142</td></tr> <tr><td>Contrapeso</td><td>Si</td></tr> <tr><td>Diám Ext.</td><td>11.91"</td></tr> <tr><td>OEM</td><td>25515222</td></tr> </table>	Dientes	142	Contrapeso	Si	Diám Ext.	11.91"	OEM	25515222
	Dientes	142																	
Contrapeso	Si																		
Diám Ext.	11.91"																		
OEM	25523510																		
Dientes	142																		
Contrapeso	Si																		
Diám Ext.	11.91"																		
OEM	25515222																		
<p>V6 181 (3.0L) Pontiac Grand Am, Delta 88 (85-88)</p>		<p>V6 231 (3.8L) Buick Century, Electra, Cutlass Ciera (84-88)</p>																	
 <p>AA-G164</p>	<table border="1"> <tr><td>Dientes</td><td>142</td></tr> <tr><td>Contrapeso</td><td>Si</td></tr> <tr><td>Diám Ext.</td><td>11.91"</td></tr> <tr><td>OEM</td><td>24501451</td></tr> </table>	Dientes	142	Contrapeso	Si	Diám Ext.	11.91"	OEM	24501451	 <p>AA-G165</p>	<table border="1"> <tr><td>Dientes</td><td>135</td></tr> <tr><td>Contrapeso</td><td>Si</td></tr> <tr><td>Diám Ext.</td><td>13.71"</td></tr> <tr><td>OEM</td><td>22512002</td></tr> </table>	Dientes	135	Contrapeso	Si	Diám Ext.	13.71"	OEM	22512002
	Dientes	142																	
Contrapeso	Si																		
Diám Ext.	11.91"																		
OEM	24501451																		
Dientes	135																		
Contrapeso	Si																		
Diám Ext.	13.71"																		
OEM	22512002																		
<p>V6 3.8L Buick Regal (90-94), Oldsmobile Silhouette (90-92), Pontiac Trans Sport (90-92)</p>		<p>V6 262 Buick Regal, Cutlass Supreme (82-85) (motor diesel Oldsmobile)</p>																	
 <p>AA-G166</p>	<table border="1"> <tr><td>Dientes</td><td>148</td></tr> <tr><td>Contrapeso</td><td>No</td></tr> <tr><td>Diám Ext.</td><td>12.40"</td></tr> <tr><td>OEM</td><td>14097667</td></tr> </table>	Dientes	148	Contrapeso	No	Diám Ext.	12.40"	OEM	14097667	 <p>AA-G167</p>	<table border="1"> <tr><td>Dientes</td><td>142</td></tr> <tr><td>Contrapeso</td><td>Si</td></tr> <tr><td>Diám Ext.</td><td>11.91"</td></tr> <tr><td>OEM</td><td>24501753</td></tr> </table>	Dientes	142	Contrapeso	Si	Diám Ext.	11.91"	OEM	24501753
	Dientes	148																	
Contrapeso	No																		
Diám Ext.	12.40"																		
OEM	14097667																		
Dientes	142																		
Contrapeso	Si																		
Diám Ext.	11.91"																		
OEM	24501753																		
<p>V6 3.4L Chevrolet Camaro, Pontiac Firebird (92-95)</p>		<p>V6 3.8L Oldsmobile 98 Regency (92-95), LSS (96-99)</p>																	
 <p>AA-G168</p>	<table border="1"> <tr><td>Dientes</td><td>142</td></tr> <tr><td>Contrapeso</td><td>Si</td></tr> <tr><td>Diám Ext.</td><td>11.91"</td></tr> <tr><td>OEM</td><td>24502775</td></tr> </table>	Dientes	142	Contrapeso	Si	Diám Ext.	11.91"	OEM	24502775	 <p>AA-G168SC</p>	<table border="1"> <tr><td>Dientes</td><td>142</td></tr> <tr><td>Contrapeso</td><td>No</td></tr> <tr><td>Diám Ext.</td><td>11.91"</td></tr> <tr><td>OEM</td><td>24502768</td></tr> </table>	Dientes	142	Contrapeso	No	Diám Ext.	11.91"	OEM	24502768
	Dientes	142																	
Contrapeso	Si																		
Diám Ext.	11.91"																		
OEM	24502775																		
Dientes	142																		
Contrapeso	No																		
Diám Ext.	11.91"																		
OEM	24502768																		
<p>V6 3.3L Century, Cutlass Ciera, Pontiac Grand Am (92-93)</p>		<p>V6 3.3L Buick Century, Oldsmobile Cutlass, Pontiac Grand Am (sin contrapeso)</p>																	

1.1 Aros dentados transmisión automática

Automatic transmission flex plates





General Motors

AA-G169 	Dientes	142
	Contrapeso	Si
	Diám Ext.	11.91"
	OEM	24501453
	V6 3.3L Buick Century, Cutlass Ciera, Pontiac Grand Am (91-92)	

AA-G170 	Dientes	142
	Contrapeso	No
	Diám Ext.	11.91"
	OEM	22533252
	L4 2.3L, 2.4L Cavalier, Malibu, Cutlass, Grand Am, Grand Prix, Sunfire (88-99)	

AA-G171 	Dientes	142
	Contrapeso	No
	Diám Ext.	11.91"
	OEM	24575991
	L4 2.2L Pick up S-10 (94-03), GMC Sonoma (94-03), Isuzu Hombre (97-00)	

AA-G172 	Dientes	142
	Contrapeso	No
	Diám Ext.	11.87"
	OEM	24576876
	L4 2.2L Cavalier (96-01), Impala V6 3.4L, 3.5L, 3.9L (00-10), Malibu V6 3.1L, 3.5L, 3.9L (99-09), Uplander V6 3.5L, 3.9L (05-07)	

AA-G173 	Dientes	142
	Contrapeso	No
	Diám Ext.	11.91"
	OEM	1648458
	V8 4.1L, 4.5L Cadillac Deville, El Dorado, Seville (85-92)	

AA-G174 	Dientes	166
	Contrapeso	No
	Diám Ext.	13.96"
	OEM	1481894
	V8 429 Cadillac (65-67)	

AA-G175 	Dientes	142
	Contrapeso	Si
	Diám Ext.	11.91"
	OEM	24508110
	V6 3.8L Buick Lacrosse (05-09), Lesabre (96-05), Impala (00-05), Monte Carlo (96-05), Oldsmobile Intrigue (98-99), Pontiac Grand Prix (04-08)	

AA-G176 	Dientes	142
	Contrapeso	No
	Diám Ext.	11.91"
	OEM	12579453
	V6 3.5L, 3.9L Impala (07-11), Malibu (08-10), Uplander (08-09)	

AA-G177 	Dientes	135
	Contrapeso	No
	Diám Ext.	11.32"
	OEM	96488000
	L4 1.6L Aveo LT, LS (04-08), Aveo5 LS (07-08)	











AA-G178 	Dientes	161
	Contrapeso	No
	Diám Ext.	13.56"
	OEM	12576272
	Trailblazer LS, LT L6 4.2L (02-08), Buick Rainier L6 4.2L (04-07)	

1.1 Aros dentados transmisión automática

Automatic transmission flex plates



General Motors

	Dientes	168		Dientes	168
	Contrapeso	No		Contrapeso	Si
	Diám Ext.	14.13"		Diám Ext.	14.13
	OEM	12551367		OEM	12555640
	V8 4.8L, 5.3L, 6.0L Silverado, Yukon, Sierra, Avalanche, Express 1500 (03-10) (transmision 4L80E / 4L85E) (sin espaciador)			V6 4.3L Silverado 1500 (99-10), GMC Sierra 1500 (99-10), (trans. 4L60E / 4L65E)	
	Dientes	168		Dientes	168
	Contrapeso	Si		Contrapeso	Si
	Diám Ext.	14.135"		Diám Ext.	14.13"
	OEM	12557584		OEM	12557587
	V6 4.3L, V8 5.7L C1500, C2500, Silverado (96-02) (transmision 4L80E)			V6 4.3L S-10, Silverado, Van Express 1500 (97-02) (transmision 4L60E)	
	Dientes	168		Dientes	168
	Contrapeso	No		Contrapeso	No
	Diám Ext.	14.13"		Diám Ext.	14.13"
	OEM	12561217		OEM	12606620 / 12580709
	V8 8.1L Suburban, Silverado, Yukon, GMC Sierra, Avalanche (01-07)			V8 4.8L, 5.3L, 6.0L, 6.2L Cheyenne, Silverado 2500, Avalanche, GMC Sierra 2500, Cadillac Escalade (03-14)	
	Dientes	168		Dientes	142
	Contrapeso	No		Contrapeso	No
	Diám Ext.	14.13"		Diám Ext.	11.91"
	OEM	12621399		OEM	3544671
	V8 4.8L, 5.3L, 6.0L, 6.2L Silverado, Yukon, Sierra, Avalanche, Express 1500 (03-14) (transmision 4L80E / 4L85E) (con espaciador)			V8 4.6L Cadillac DeVille, Seville SLS, STS, Eldorado (93-02)	
	Dientes	135		Dientes	142
	Contrapeso	No		Contrapeso	Si
	Diám Ext.	11.32"		Diám Ext.	11.91"
	OEM	90236309		OEM	12609154
	L4 1.6L Chevy Monza, Chevy C2 (98-10), Aveo 1.6L (08-14), Astra 1.8L (01-03)			V6 3.8L Impala SS, Montecarlo SS, Grand Prix GTP, supercargados (97-05)	

1.1 Aros dentados transmisión automática

Automatic transmission flex plates





General Motors

AA-G191 	Dientes	142
	Contrapeso	No
	Diám Ext.	11.91"
	OEM	12575076
	V6 3.4L, 3.6L Chevrolet Equinox, Pontiac Torrent (05-09)	

AA-G192 	Dientes	135
	Contrapeso	No
	Diám Ext.	11.32"
	OEM	12647333 / 12593689
	L4 2.4L Captiva Sport (13-15), Equinox (10-15), Malibu (06-14), HHR (05-10) GMC Terrain (14-15) Cavalier L4 2.2L (02-05)	

Honda

AA-H900 	Dientes	N / A
	Contrapeso	No
	Diám Ext.	11.80"
	OEM	26251-P8F-000
	V6 3.0L, 3.5L Odyssey (05-06), Accord (06-07)	

AA-H901 	Dientes	N / A
	Contrapeso	No
	Diám Ext.	11.27"
	OEM	26251-PNA-000
	L4 2.4L Accord, CR-V (11-13), Element (02-11)	

Kia

AA-K800 	Dientes	112
	Contrapeso	No
	Diám Ext.	11.38"
	OEM	0K32B19020
	L4 1.5L, 1.6L Kia Rio (01-05)	

AA-K801 	Dientes	112
	Contrapeso	No
	Diám Ext.	11.38"
	OEM	0K25R19020A
	L4 1.8L Kia Spectra (00-03), Kia Sephia (98-01)	

AA-K802 	Dientes	120
	Contrapeso	No
	Diám Ext.	12.06"
	OEM	23210-36500
	V6 3.5L Kia Sorento (03-04)	

1.1 Aros dentados transmisión automática

Automatic transmission flex plates



Mitsubishi

AA-M700 	Dientes	N / A
	Contrapeso	N / A
	Diám Ext.	N / A
	OEM	MD707923
	L4 1.5L Mirage, Vista, Colt (89-96) (5 agujeros al centro)	

AA-M701 	Dientes	N / A
	Contrapeso	N / A
	Diám Ext.	N / A
	OEM	MD707924
	L4 1.8L, 2.0L Cordia, Eclipse, Galant (83-94) (6 agujeros al centro)	

AA-M702 	Dientes	N / A
	Contrapeso	N / A
	Diám Ext.	9.375"
	OEM	N / D
	L4 2.0L, 2.4L Eclipse, Expo, Galant (93-99) (7 agujeros al centro)	

AA-M703 	Dientes	N / A
	Contrapeso	N / A
	Diám Ext.	9.625"
	OEM	MD758464
	L4 1.5L Mitsubishi Mirage (97-02)	

Nissan

AA-N501 	Dientes	105
	Contrapeso	No
	Diám Ext.	10.735"
	OEM	12331-12M20
	L4 1.5L, 1.6L Tsuru I y II (84-92)	

AA-N502 	Dientes	105
	Contrapeso	No
	Diám Ext.	10.735"
	OEM	12331-75Y10
	L4 1.6L Tsuru III (8 válvulas) (93-95)	

AA-N503 	Dientes	105
	Contrapeso	No
	Diám Ext.	10.735"
	OEM	12331-78A10
	L4 1.6L Tsuru III (16 válvulas) (93-16)	

AA-N504 	Dientes	120
	Contrapeso	No
	Diám Ext.	12.05"
	OEM	12331-U9511
	L4 2.2L Pick up 720 (81-82), 280Z L6 2.8L (75-78), 280ZX L6 2.8L (79-83)	

1.1 Aros dentados transmisión automática

Automatic transmission flex plates



Nissan

AA-N505 	Dientes	120
	Contrapeso	No
	Diám Ext.	12.05"
	OEM	12303-N9511
	L4 1600, 1800 Datsun automovil (74-83)	

AA-N506 	Dientes	120
	Contrapeso	No
	Diám Ext.	12.05"
	OEM	12331-24G02
	L4 2.0L, 2.2L, 2.4L Datsun autos y pick ups motores Z20, Z22 y Z24 (80-89)	

AA-N507 	Dientes	105
	Contrapeso	No
	Diám Ext.	10.735"
	OEM	12312-01M01
	L4 1488cc (1.5L), 1597cc (1.6L) Nissan 310 (1982), Pulsar NX (83-88) (U.S.A.) (transmision RN / RL3F01A)	

AA-N508 	Dientes	120
	Contrapeso	No
	Diám Ext.	12.05"
	OEM	12331-17C00
	L4 2.4L (KA24E) Pick Up D21, SE, XE, 2.4L KA24E (91-98)	

AA-N509 	Dientes	120
	Contrapeso	No
	Diám Ext.	12.05"
	OEM	12331-16E11
	V6 3.0L Maxima (85-94)	

AA-N510 	Dientes	122
	Contrapeso	No
	Diám Ext.	10.14"
	OEM	37537-1800R
	Nissan Platina 1.6L K4M (02-11)	

Toyota

AA-T600 	Dientes	115
	Contrapeso	No
	Diám Ext.	11.60"
	OEM	32101-20050
	L4 2189cc (2.2L), 2366cc (2.4L) Pick ups Toyota (75-95), 4Runner (84-95), Celica (75-85), motores 20R, 22R, 22RE (6 tornillos cigüeñal)	

AA-T601 	Dientes	115
	Contrapeso	No
	Diám Ext.	11.60"
	OEM	32101-26010
	L4 2.4L, 2.7L Tacoma (95-12), T-100 (95-98), 4Runner (96-00) (10 tornillos cigüeñal)	

1.1 Aros dentados transmisión automática

Automatic transmission flex plates



Toyota

	AA-T602	Dientes	106
		Contrapeso	No
		Diám Ext.	10.66"
		OEM	32101-12060
	L4 1.6L, 1.8L Celica (96-97), Corolla (83-97) (6 tornillos cigüeñal)		

	AA-T603	Dientes	120
		Contrapeso	No
		Diám Ext.	11.95"
		OEM	32101-32051
	L4 2.0L, 2.2L Camry (90-01), Celica (90-99), MR2 (91-95), Solara (99-01) (8 tornillos cigüeñal)		

	AA-T604	Dientes	120
		Contrapeso	No
		Diám Ext.	11.95"
		OEM	32101-35010
	V6 3.0L, 3.4L 4Runner (88-02), Tacoma (95-04), T-100 (93-98), Tundra (00-04), Pick ups Toyota (89-95) (8 tornillos cigüeñal)		

Volkswagen

	AA-VW600	Dientes	132
		Contrapeso	No
		Diám Ext.	11.12"
		OEM	053105323E
	L4 1588cc (1.6L), 1715cc (1.7L), 1780cc (1.8L) Caribe, Golf, Jetta (76-92)		



LODI Industrias Automotrices

www.lodi.com.mx



DESDE 1969

La línea mas completa en el mercado nacional

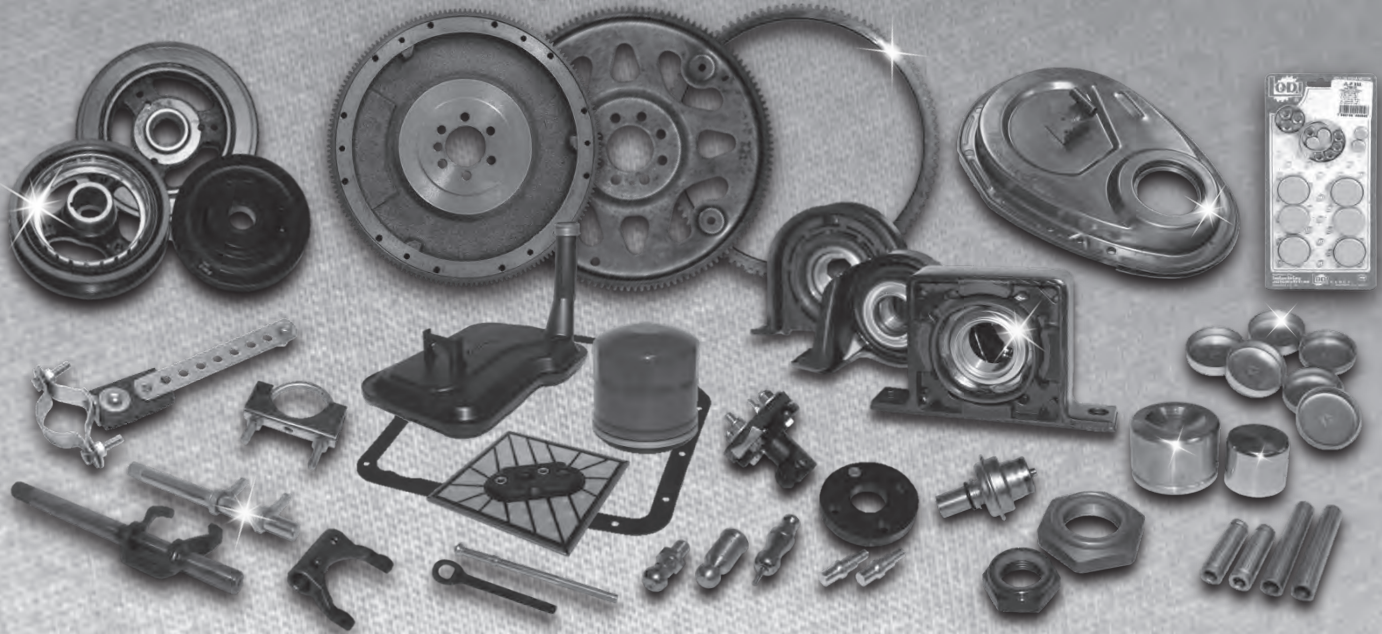

- Filtro y empaque de transmisión automática
- Aros dentados
- Juegos de sellos para monoblock
- Guías de válvula
- Soportes de barra cardán
- Poleas de cigüeñal
- Tapas de distribución
- Horquillas de Clutch
- Partes para sistema de freno
- Partes para dirección
- Miscelánea

Consulta nuestro catálogo
y conoce nuestra gama
completa de productos.

www.lodi.com.mx

SOPORTE TÉCNICO
01 800 227 5634



LODI Industrias Automotrices



811 813 4207

1.2 Aros dentados transmisión estándar Flywheel ring gear



NO LODI	NO ORIGINAL	MOTORES
---------	-------------	---------

American Motors / Jeep

AS-153R	3172419	123, 199, 258 (65-72)
AS-164A	3179741	232, 258, 282, 304, 360, 401 Transmisión MT (72-88)

Chrysler / Dodge

AS-090A	23212-02510	Atos 1.0L, 1.1L (00-adelante)
AS-122T	2121196 / 2863495	170, 225, 272, 273, 318, 360, 426 (62-89)
AS-130C	3515203	Plymouth L6 y V8 (74-89)
AS-130T	1941648 / 2863497	272, 318, 383, 426, 440 (62-87)
AS-139A	5222789	135 (2.2L) Serie K
AS-139 CH	4348276	135 (2.2L) y 156 (2.6L) Serie K
AS-139CF	838177	135 (2.2L) y 156 (2.6L) Serie K (aro delgado)
AS-143N	2843214	225, 318, 360, 383, 440 Embrague 11" o 12" (68-89), Pick up Ram V6 3.9L, V8 5.2L, 5.9L (94-02)
AS-146XF	1138903 / 1119963 / 8057373439	C6, C13, C22, C24, C25, C28, C34, C164 (Camionetas)
AS-148T	2121195 / 2863496	170, 225 (Dodge y Plymouth) 148NC
AS-158A	3732638	Dodge 225, 318, 360, (74-77) Pickups
AS-172S	2863494	225, 273, 318, 326, 361, 383, 392, 413 (60-77)
AS-186T	1733880	318, 360, 361, 383, 413 CID Embrague 13" (Camionetas)

Cummins

AS-103T	6771283 / 4797	L6 250, 400
AS-127D	3905427	Dina V6 y V8 140, 155, 185, 210

Ford

AS-112NR	8BA-6384 A	239 (48-53)
AS-132E	D4FZ-6384 A	98, 116, 140, 153, 182 (Taurus y Topaz), Ranger 2.3L
AS-132F	C0DP-6384 A	144, 170, 200, 223 Turbina de transmisión automática
AS-134XR	9 N 6384	Tractor 4 cil. (39-88)
AS-135A	D1FZ-6384-A	Pinto 1.6 L, 2.0 L (71-74)
AS-138RY	D2RY-6384-A	Bronco, Ranger 2.8L, 2.9L (83-96)
AS-146SR	EAA-6384-A	223, 272, 292, 293, 312 (52-67)
AS-148S	PMB-6384-A / B8A-6375 D	Ford 292 (58-62)
AS-155FT	E5TZ-6384 B	239, 272, 292, 312 Transmisión automática
AS-157N	C2OZ-6384-A / C7OP-6384-A	170, 200, 221, 230, 250, 289, 302 (62-89)
AS-160T		Falcon 170, 188, 221, 250
AS-164N	C5AZ-6384-A	289, 302, 351 (65-96), 4.6L, 5.4L (97-10)
AS-168R	Z5AZ-6384-A	286, 302, 351 (65-70 y 83-84)
AS-180W	D7TZ-6384-A	F600, 335, 351, 370, 400, 429, 460 (77-89)
AS-184T	Z5AZ-6384-A/C5AZ-6384-A	327, 390, 410 (65-78)
AS-188T	C4TZ-6384-A	330, 359, 361, 389, 391 (Camionetas 64-78)

1.2 Aros dentados transmisión estándar Flywheel ring gear



NO LODI	NO ORIGINAL	MOTORES
---------	-------------	---------

General Motors

AS-135GM		Chevy, Monza, Joy y Swing
AS-139G	14077156	216 6 Cil. (40-54)
AS-142W	359115	173 6 Cil. Celebrity y Citation
AS-148B	14033090	L4 121 (2.0L) y V6 173 (2.8L) 82-89
AS-153N	3789821	C10, C20, 250, 307, 350, 370, 396
AS-168S	460583 / 3991408	250, 283, 292, 307, 350 (69-03), 4.3L, 4.8L, 5.3L (04-10)
AS-191T	2369440	V6 305, 351, 379, 401 (60-76)
AS-197B	3991409	366, 348, 350 (5.7L), 366, 386, 427 (58-88)
AS-197N	3737920	V8 327, 350, 366, 409, 427 (62-78)
AS-204A	14001923	V8 427, 454 (79-89)

Honda

AS-103H		Prelude (88-84)
AS-107S		Legend (86-89)
AS-114A		

John Deere

AS-129F	R28811	
---------	--------	--

Mercedes Benz

AS-140Z	615032, 0105	
---------	--------------	--

Mitsubishi

AS-106M	MD030629	Eclipse (92-99), Eagle Talon (92-99)
AS-110MI		Autos y pick ups motores 4G32, 4G37, 4G63, 6G72 (83-04)

Navistar

AS-138L	1815440C1	Navistar e International
---------	-----------	--------------------------

Nissan / Datsun

AS-105	12312-61A00	Tsuru I, II y III (84-94)
AS-105A	12312-F4100	Tsuru III 16 válvulas GA16DE (95-10)
AS-105G	12312-18000	Datsun 68-84
AS-108T	12312-01M10	Tsuru 1500
AS-115N	12312-09600	1500, 1600
AS-119C	8200279345	Nissan Platina, Renault Clio L4 1.6L (02-11)
AS-120C	12312-6100	1800, 1952, 2187, 2393, 2753
AS-146Z	12312-58000	Z20, Z22 y Z24, 2.0L, 2.2L, 2.4L (81-90)

1.2 Aros dentados transmisión estándar Flywheel ring gear



NO LODI	NO ORIGINAL	MOTORES
---------	-------------	---------

Perkins

AS-126F	B4010236	354 6 Cil. (60-75)
---------	----------	--------------------

Toyota

AS-106C	13453-10010	L4 1077cc 1166cc, 1290cc (68-86)
AS-115C	13453-20010	4 y 6 cil. (68-85)
AS-136C	13453-60010	6 cil. 4230cc (74-86)

Volkswagen

AS-125C	055 105 275	Caribe 1700 4 cil.
AS-130VW	043 105 275	Sedán 1600
AS-132P	056 105 275C	Pointer, autos y pick ups (97-07)
AS-132VW	068 105 275A	Golf, Jetta, New Beetle (92 en adelante)

1.3 Aros dentados transmisión estándar dimensiones Flywheel ring gear dimensions

Número LODI	Marca	Diámetro exterior	Diámetro interior	Espesor	No. de dientes	Chañlán	Paso
AS-090A	CHRYSLER / HYUNDAI	9.060"	8.340"	0.355"	90	REVERSO	
AS-103T	CUMMINS	17.385"	15.996"	0.871"	103	FRENTE	6/8
AS-103H	HONDA	10.625"	10.450"	0.355"	103	FRENTE	
AS-105G	NISSAN	10.725"	9.425"	0.390"	105	REVERSO	10/12S
AS-105	NISSAN	10.725"	9.425"	0.390"	105	FRENTE	10/12S
AS-105A	NISSAN	10.740"	9.695"	0.399"	105	FRENTE	
AS-106C	TOYOTA	10.670"	9.520"	0.318"	106	FRENTE	
AS-106M	MITSUBISHI	10.669"	9.665"	0.331"	106	FRENTE	
AS-107S	HONDA	10.766"	9.603"	0.354"	107	FRENTE	10
AS-108T	NISSAN	10.740"	9.460"	0.321"	108	FRENTE	8/10
AS-110MI	MITSUBISHI	11.095"	10.400"	0.388"	110	REVERSO	
AS-112NR	FORD	14.180"	12.868"	0.370"	112	REVERSO	8/10
AS-114A	HONDA	11.540"	10.030"	0.381"	114	FRENTE	10/12
AS-115N	NISSAN	11.620"	10.340"	0.475"	115	FRENTE	10
AS-115C	TOYOTA	11.600"	10.200"	0.361"	115	FRENTE	
AS-119C	NISSAN / RENAULT	10.125"	9.240"	0.320"	119	SIN	
AS-120C	NISSAN	12.051"	10.780"	0.475"	120	FRENTE	10
AS-122T	CHRYSLER	12.276"	11.190"	0.350"	122	SIN	10
AS-125C	VW	10.588"	9.856"	0.325"	125	SIN	11.85
AS-126F	PERKINS	15.930"	14.819"	0.702"	126	SIN	8/10
AS-127D	CUMMINS	16.050"	14.998"	0.735"	127	FRENTE	8/10
AS-129F	JOHN DEERE	16.353"	15.171"	0.562"	129	FRENTE	8/10
AS-130T	CHRYSLER	13.195"	12.160"	0.375"	130	SIN	10
AS-130VW	VW	10.878"	9.993"	0.375"	130	SIN	12
AS-130C	CHRYSLER	10.878"	9.993"	0.375"	130	SIN	12
AS-132E	FORD	11.256"	10.141"	0.365"	132	SIN	12.025
AS-132F	FORD	11.157"	10.309"	0.365"	132	SIN	12/14
AS-132VW	VW	11.050"	10.150"	0.412"	132	SIN	
AS-132P	VW	11.060"	10.040"	0.318"	132	SIN	
AS-134XR	FORD	13.530"	12.000"	0.364"	134	REVERSO	
AS-135A	FORD	11.293"	10.402"	0.365"	135	SIN	12

1.3 Aros dentados transmisión estándar dimensiones Flywheel ring gear dimensions



Número LODI	Marca	Diámetro exterior	Diámetro interior	Espesor	No. de dientes	Chaflán	Paso
AS-135GM	GENERAL MOTORS	11.350"	10.260"	0.353"	135	SIN	
AS-136C	TOYOTA	13.740"	12.525"	0.510"	136	FRENTE	10/12
AS-138RY	FORD	11.642"	10.475"	0.373"	138	SIN	12
AS-138L	INTERNATIONAL / NAVISTAR	17.430"	16.250"	0.640"	138	FRENTE	
AS-139A	CHRYSLER	11.767"	10.823"	0.331"	139	SIN	12
AS-139CF	GENERAL MOTORS	14.015"	13.060"	0.500"	139	FRENTE	10/12
AS-139CH	CHRYSLER	14.130"	13.271"	0.5"	139	FRENTE	10
AS-139G	GENERAL MOTORS	14.130"	13.271"	0.455"	139	FRENTE	
AS-140Z	MERCEDES	11.794"	10.553"	0.468"	140	FRENTE	12
AS-142W	GENERAL MOTORS	11.910"	11.088"	0.453"	142	SIN	12
AS-143N	CHRYSLER	14.568"	13.560"	0.340"	143	SIN	10
AS-146SR	FORD	14.774"	13.352"	0.365"	146	SIN	10
AS-146XF	CHRYSLER	14.640"	13.560"	0.375"	146	FRENTE	10
AS-146Z	NISSAN	14.713"	13.645"	0.560"	146	FRENTE	10
AS-148A	GENERAL MOTORS	12.397"	11.400"	0.375"	148	SIN	
AS-148S	FORD	15.007"	14.013"	0.370"	148	SIN	10/12
AS-148T	CHRYSLER	12.520"	11.189"	0.370"	148	SIN	12
AS-148B	GENERAL MOTORS	12.410"	11.588"	0.453"	148	SIN	12
AS-153N	GM	12.835"	12.003"	0.440"	153	SIN	12/14
AS-153R	AMC	12.825"	11.793"	0.440"	153	SIN	12/14
AS-155FT	FORD	15.700"	14.435"	0.501"	155	FRENTE	
AS-157N	FORD	13.294"	12.025"	0.365"	157	SIN	12/14
AS-158A	CHRYSLER	15.865"	14.650"	0.355"	158	SIN	
AS-160T	FORD	13.250"	12.000"	0.363"	160	SIN	
AS-164A	AMC	13.830"	12.820"	0.420"	164	SIN	12/14
AS-164N	FORD	14.215"	12.955"	0.375"	164	SIN	12 ESP
AS-168R	FORD	14.190"	13.232"	0.440"	168	SIN	12 ESP
AS-168S	GENERAL MOTORS	14.096"	13.268"	0.440"	168	SIN	12/14
AS-172S	CHRYSLER	14.640"	13.561"	0.35"	172	SIN	12
AS-180W	FORD	15.512"	14.518"	0.440"	180	SIN	12
AS-184T	FORD	15.512"	14.210"	0.375"	184	SIN	12/14
AS-186T	CHRYSLER	15.503"	14.691"	0.375"	186	SIN	12
AS-188T	FORD	15.869"	14.728"	0.375"	188	SIN	12
AS-191T	GENERAL MOTORS	16.102"	15.012"	0.485"	191	SIN	12/14
AS-197B	GENERAL MOTORS	15.970"	15.682"	0.453"	197	SIN	12/14 M
AS-197N	FORD	16.522"	15.670"	0.437"	197	SIN	12
AS-204A	GENERAL MOTORS	17.107"	16.267"	0.453"	204	SIN	12/14

MAX
performance

BOBINAS DE IGNICIÓN

Calidad de equipo original

Amplia cobertura de aplicaciones!



LODI Industrias Automotrices



Dale Like !



1.4 Partes y repuestos para transmisión automática

Automatic transmission parts

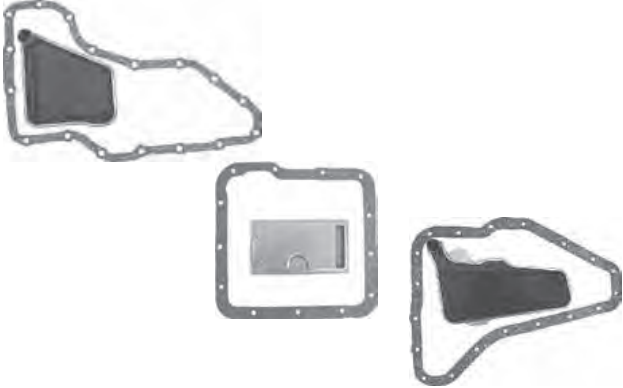

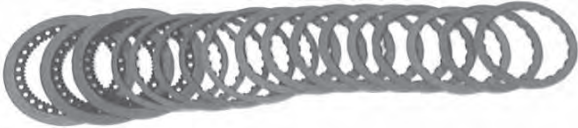
 <p>FE: Filtro y empaque</p>	 <p>MO: Modulador</p>
 <p>JDA: Juego Completo de Discos de Acero</p>	 <p>JDF: Juego Completo de Discos de Fricción</p>

JC: JUEGO COMPLETO

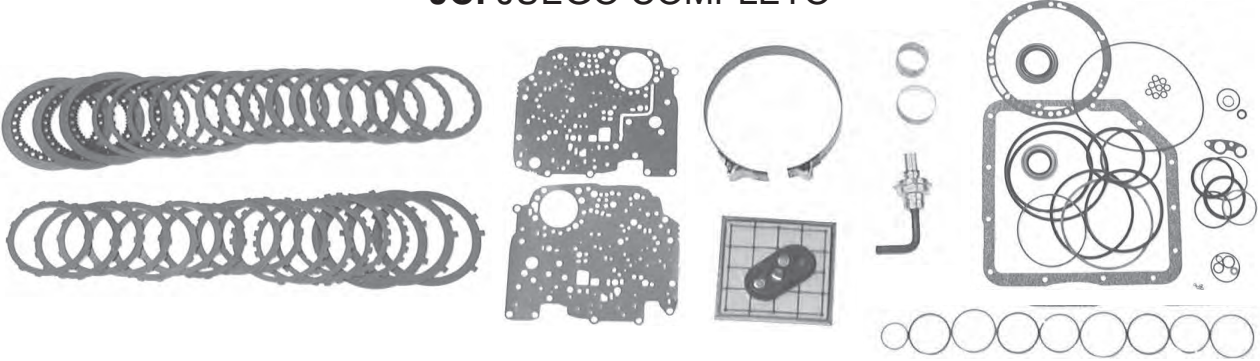

JC: Juego completo (Deluxe kit), Cartera de empaques completa, los discos de fricción (JDF), discos de acero (JDA), filtro, banda, modulador (MO) y bujes de bomba y extensión

1.4 Partes y repuestos para transmisión automática

Automatic transmission parts



Juego completo deluxe kit (JC)

JC contiene: Juego completo, contiene la carter de empaques completa, los discos de fricción (**JDF**), discos de acero, filtro, banda, modulador (**MO**) y bujes de bomba y extensión

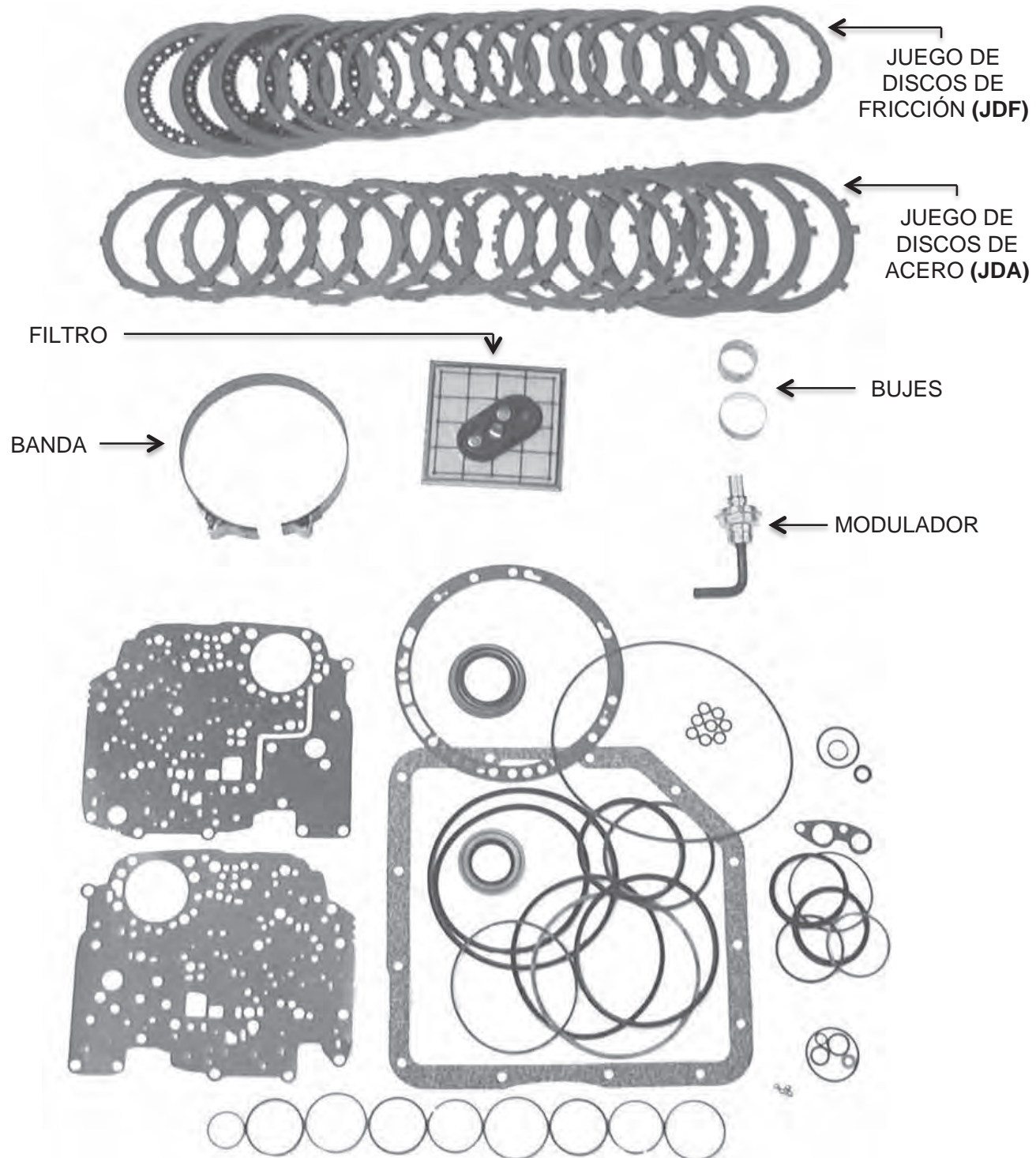

1.4 Partes y repuestos para transmisión automática Automatic transmission parts



Juegos completos

Número LODI	Marca	Aplicación
JC-A404F	CHRYSLER / DODGE	Transmisión A404 Tipo K; 4 cil; 3 vel; 78-82, filtro felpa
JC-A404M	CHRYSLER / DODGE	Transmisión A404, 413, 470 tipo K; 4 cil ; desde 82, filtro felpa
JC-A604	CHRYSLER / DODGE	Transmisión A604 Spirit y Shadow; 4 cil ; 4 vel ; desde 88
JC-TF6	CHRYSLER / DODGE	Transmisión TF6-904 6 cil ; 3 vel ; desde 66
JC-TF8	CHRYSLER / DODGE	Transmisión TF8-727 8 cil ; 3 vel ; desde 75
JC-4EAT	FORD	Transmisión 4EAT, Ford y Mazda, 4 vel., desde 91
JC-A4LD	FORD	Transmisión A4LD 4 y 6 cil. , 4 vel; desde 89
JC-A4LDA	FORD	Transmisión A4LD 4 y 6 cil. , 4 vel; desde 89
JC-A4LDE	FORD	Transmisión A4LDE, Ford Pick ups 4 y 6 cil., 4 vel., desde 95
JC-ATX	FORD	Transmisión ATX Topaz y Sable; 4 cil; 3 vel; desde 81
JC-AXOD	FORD	Transmisión AXOD 3.0L y 3.8L; V6 ; 3 vel ; desde 86
JC-AXODE	FORD	Transmisión AXOD 3.0L y 3.8L; V6 ; 3 vel ; desde 86, elect
JC-C3	FORD	Transmisión C3 Fairmont, Cougar; V6, V8; 3 vel; 74-88
JC-C4A	FORD	Transmisión C4 Merc., Camionetas; V6, V8; 3 vel; 69-81, 70-77
JC-C4N	FORD	Transmisión C4 Merc., Camionetas; V6, V8; 3 vel; 69-81, 78-81
JC-C5	FORD	Transmisión C5 Mercury y Camionetas; V6 y V8; 3 vel ; desde 82
JC-C6A	FORD	Transmisión C6 Mercury y Camionetas; V8 3 vel, 66-77
JC-C6N	FORD	Transmisión C6 Mercury y Camionetas; V8 ; 3 vel, desde 77
JC-CD4E	FORD	Transmisión CD4E, Ford y Mazda, 4 vel., 94-02
JC-CD4E	FORD	Transmisión CD4E, Ford y Mazda, 4 vel., 94-02
JC-E4OD	FORD	Transmisión E4OD, Ford Pick ups V8, 4 vel., 89-04
JC-FIOD	FORD	Transmisión FIOD / AOD; 302 y 351; V8; 4 vel.
JC-FIODE	FORD	Transmisión FIOD / AOD ; 302 y 351 ; V8; 4 vel, electrónico
JC-FMX	FORD	Transmisión FMX Mercury y Cam ; V8; 3 vel; 68-77
JC-4L80E	GM	Transmisión 4L80E, GM Pick ups, V8, 4 vel., desde 97
JC-TH125	GM	Transmisión TH125 Celebrity, Cavalier; V6 ; 3 vel
JC-TH125N	GM	Transmisión TH125, GM autos, 3 vel; 87-02
JC-TH180	GM	Transmisión TH180, GM autos, 3 vel., 69-87
JC-TH200	GM	Transmisión TH200 V6 y V8, 3 y 4 vel.; 76-79
JC-TH200R4	GM	Transmisión TH200-4R , GM autos y pick ups, V6 y V8, 4 vel, 81-90
JC-TH350	GM	Transmisión TH250 y TH350, V6 y V8; 3 velocidades
JC-TH350LU	GM	Transmisión TH250 y TH350; V6 y V8; 3 velocidades, lock-up
JC-TH400	GM	Transmisión TH400 V8 ; 3 vel ; 67-89
JC-TH440	GM	Transmisión 4T60E Cutlass; V6; 3.1L; 4 vel ; desde 93
JC-TH700R4	GM	Transmisión TH700 V6 y V8; 4 velocidades
JC-TH700R4A	GM	Transmisión TH700R4, GM autos y pick ups, V6 y V8, 4 vel. , 82-86
JC-TH700R4E	GM	Transmisión TH700 V6 y V8 ; 4 velocidades, electrónico
JC-JATCO	NISSAN	Transmisión 3N71A JATCO ; 4 cil ; 3 vel ; 71-87
JC-SENTRA	NISSAN	Transmisión RL4F03A Tsuru y Sentra; 4 vel; desde 91
JC-TSURU	NISSAN	Transmisión RL3F01A Tsuru I y II; 4 cil; 3 vel ; 81-88
JC-VW010	VOLKSWAGEN	Transmisión VW010 Caribe y Golf; 4 cil; 3 vel ; 76-89
JC-VW095	VOLKSWAGEN	Transmisión VW095, VW Golf, Jetta, 4 vel. , 90-95

¿ALGUNA
DUDA?



01-800-CAS-LODI
01 800 227 5634
info@lodi.com.mx

SOPORTE TÉCNICO



LODI Industrias Automotrices

Dale Like!

1.4 Partes y repuestos para transmisión automática

Automatic transmission parts



Juego de discos de acero

Número LODI	Marca	Aplicación
JDA-A404	CHRYSLER / DODGE	Transmisión A404 tipo K ; 4 cil ; 3 vel ; 78-82 / 413, 470; desde 82, 7 discos
JDA-A604	CHRYSLER / DODGE	Transmisión A604 Spirit y Shadow; 4 cil; 4 velocidades ; desde 88
JDA-TF6	CHRYSLER / DODGE	Transmisión TF6-904 6 cil; 3 velocidades ; desde 66
JDA-TF8	CHRYSLER / DODGE	Transmisión TF8-727 8 cil ; 3 velocidades; desde 75
JDA-ATX	FORD	Transmisión ATX Topaz y Sable ; 4 cil ; 3 velocidades; desde 81
JDA-AXOD	FORD	Transmisión AXOD 3.0L y 3.8L; V6 ; 3 velocidades; desde 86
JDA-C3	FORD	Transmisión C3 Fairmont, Cougar; V6, V8; 3 velocidades; 74-88
JDA-C4/C5	FORD	Transmisión C4 Merc., Camionetas; V6, V8; 3 velocidades; 69-81 Transmisión C5 Mercury y Camionetas V6 y V8; 3 velocidades; desde 82
JDA-C6	FORD	Transmisión C6 Mercury y Camionetas; V8 ; 3 velocidades
JDA-FIOD	FORD	Transmisión FIOD / AOD ; 302 y 351 ; V8 4 velocidades
JDA-FMX	FORD	Transmisión FMX Mercury y Cam. ; V8 ; 3 velocidades; 68-77
JDA-TH125	GENERAL MOTORS	Transmisión TH125 Celebrity, Cavalier V6 ; 3 velocidades
JDA-TH200	GENERAL MOTORS	Transmisión TH200 V6 y V8; 3 y 4 velocidades; 76-79
JDA-TH350	GENERAL MOTORS	Transmisión TH250 y TH350; V6 y V8 ; 3 velocidades
JDA-TH400	GENERAL MOTORS	Transmisión TH400 V8 ; 3 velocidades; 67-89
JDA-TH700R4	GENERAL MOTORS	Transmisión TH700 V6 y V8 ; 4 velocidades
JDA-JATCO	NISSAN	Transmisión 3N71A JATCO; 4 cil ; 3 velocidades; 81-88, 12 discos
JDA-TSURU	NISSAN	Transmisión RL3F01A Tsuru I y II; 4 cil ; 3 velocidades; 81-88, 12 discos
JDA-VW010	VOLKSWAGEN	Transmisión VW010 Caribe y Golf ; 4 cil ; 3 vel ; 76-89 , 12 discos

Juego de discos de fricción

Número LODI	Marca	Aplicación
JDF-A404	CHRYSLER / DODGE	Transmisión A404 tipo K ; 4 cil ; 3 velocidades ; 78-82 , 6 discos
JDF-A404N	CHRYSLER / DODGE	Transmisión A404, 413, 470 tipo K; 4 cil ; desde 82 , 8 discos
JDF-A604	CHRYSLER / DODGE	Transmisión A604 Spirit y Shadow; 4 cil ; 4 velocidades, desde 88
JDF-TF6	CHRYSLER / DODGE	Transmisión TF6-904 6 cil ; 3 velocidades; desde 66, 8 discos
JDF-TF8	CHRYSLER / DODGE	Transmisión TF8-727 8 cil ; 3 velocidades; desde 75 , 8 discos
JDF-ATX	FORD	Transmisión ATX Topaz y Sable; 4 cil ; 3 velocidades ; desde 81 , 11 discos
JDF-AXOD	FORD	Transmisión AXOD 3.0L y 3.8L ; V6; 3 velocidades ; desde 86 , 17 discos
JDF-C3	FORD	Transmisión C3 Fairmont, Cougar ; V6, V8 ; 3 velocidades; 74-88, 9 discos
JDF-C4/C5	FORD	Transmisión C4 Merc., Camionetas; V6, V8 , 3 velocidades; 69-81, 9 discos Transmisión C5 Mercury y Cam; V6 y V8; 3 velocidades; desde 82 , 9 discos
JDF-C6A	FORD	Transmisión C6 Mercury y Camionetas ; V8 ; 3 velocidades, 13 discos
JDF-FIOD	FORD	Transmisión FIOD / AOD; 302 y 351; V8 ; 4 velocidades, 21 discos 80-90
JDF-FIODE	FORD	Transmisión FIOD / AOD; 302 y 351; V8 ; 4 velocidades , 18 discos 92-95
JDF-FMX	FORD	Transmisión FMX Mercury y Cam. ; V8 ; 3 velocidades ; 68-77 , 9 discos
JDF-TH125	GENERAL MOTORS	Transmisión TH125 Celebrity , Cavalier; V6 ; 3 velocidades , 13 discos
JDF-TH200	GENERAL MOTORS	Transmisión TH200 V6 y V8; 3 y 4 velocidades; 76-79 , 11 discos
JDF-TH350	GENERAL MOTORS	Transmisión TH250 y TH350; V6 y V8 ; 3 velocidades, 17 discos
JDF-TH400	GENERAL MOTORS	Transmisión TH400 V8; 3 velocidades; 67-89 , 12 discos
JDF-TH700A	GENERAL MOTORS	Transmisión TH700 V6 y V8; 4 velocidades, 82-84
JDF-TH700N	GENERAL MOTORS	Transmisión TH700 V6 y V8; 4 velocidades, 84-87
JDF-TH700R4	GENERAL MOTORS	Transmisión TH700 V6 y V8; 4 velocidades, 87-92, 22 discos
JDF-JATCO	NISSAN	Transmisión 3N71A JATCO; 4 cil ; 3 velocidades; 71-87, 12 discos
JDF-TSURU	NISSAN	Transmisión RL3F01A Tsuru I y II; 4 cil ; 3 velocidades; 81-88, 11 discos
JDF-VW010	VOLKSWAGEN	Transmisión VW010 Caribe y Golf; 4 cil ; 3 velocidades; 76-89, 11 discos

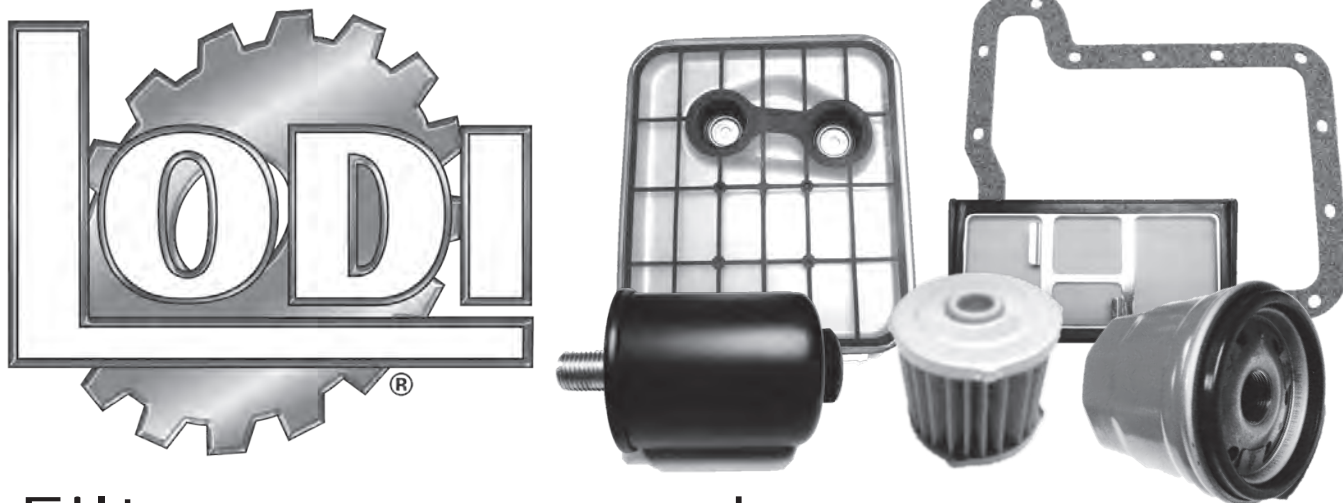

Filtro y empaque de transmisión automática

Existen diferentes tipos de filtros para transmisión automática, la diferencia entre estos radica en el tipo de material usado como elemento filtrante, los cuales son:

Filtro o felpa

El filtro de fieltro o felpa tiene como principal característica, un alto nivel de filtración y un excelente flujo de fluido. Las fibras del filtro, están impregnadas de resina fenólica, añadiéndole la fuerza y capacidad de soportar la temperatura del fluido al más alto nivel del rango de operación de la transmisión. Filtra partículas de hasta aproximadamente 60 micras.

Latón

Elemento filtrante elaborado a base de malla de latón. Fuerte y duradero. La capacidad de filtración varía en función del tamaño de la malla; puede variar de 117 a 205 micras.

Acero

Elemento filtrante elaborado a base de malla de acero. Fuerte y duradero. La capacidad de filtración varía en función del tamaño de la malla, que puede ser de 75 a 190 micras.

Plástico/Nylon

El elemento filtrante es a base de una malla de nylon. Filtra partículas de hasta aproximadamente 130 micras.

Papel

Esta impregnado con resina fenólica, lo cual le adhiere fuerza y la capacidad de soportar altas temperaturas del fluido. Filtra partículas de hasta aproximadamente 30 a 40 micras.

Filtro sellado (Elemento de papel)

Soporta altas temperaturas del fluido. Filtra partículas de hasta aproximadamente 30 a 40 micras.

Filtro magnético

Cuenta con un poderoso imán capaz de atraer los contaminantes ferrosos. Diseñado para proporcionar una eficaz filtración mientras se mantiene el flujo adecuado de fluidos. El elemento de papel filtra las partículas de metales no ferrosos. Filtra partículas de hasta aproximadamente 25 micras.

Empaque o junta de corcho

Combinación balanceada de corcho 100% virgen y nitrilo. Resistente a las altas temperaturas del aceite. Proporciona la compresibilidad exacta para un perfecto sellado.

Empaque o junta de corcho ahulado

Combinación de hule sintético y de corcho. Gran resistencia a las temperaturas elevadas del aceite. Gracias a sus cualidades de compresibilidad y capacidad de recuperación, garantizan un óptimo sellado



Procedimiento de instalación:

- 1) Coloque una charola o recipiente justo debajo del cárter de la transmisión.
- 2) Retire los tornillos de un lado del cárter y empiece a aflojar los del lado contrario. Con esta acción, el cárter se inclinara, lo que permitirá que el aceite comience a drenar.
- 3) Ya que se haya drenado la mayor parte del aceite, retire el resto de los tornillos junto con el cárter. Vacíe el aceite restante en la charola o recipiente.
- 4) Retire los restos de empaque del cárter y de la superficie de la transmisión. Si el cárter cuenta con un imán, retírelo, límpielo y vuélvalo a instalar.
- 5) Retire el filtro usado, y de ser necesario, compárelo con el nuevo. A continuación, instale el filtro nuevo.
- 6) Presente y coloque el empaque nuevo en el cárter. Coloque algunos tornillos en el cárter, a distancia unos de otros, esto permitirá que el empaque permanezca en su lugar al momento de la instalación. Procure no utilizar ningún tipo de sellador. Continúe con la instalación del cárter, apoyándose con los tornillos instalados previamente en el mismo y luego con el resto de los demás.
- 7) Apriete los tornillos de manera alternada hasta que todos queden ajustados. Procure no apretarlos de mas (10 a 12 lbs/pie son suficientes). Si son apretados de más, existe el riesgo de que el empaque sufra daño y tenga como consecuencia, que se presenten fugas de fluido.
- 8) Agregue la cantidad de aceite nuevo indicada por el fabricante. No lo llene de más.
- 9) Con el motor encendido y en marcha mínima, con la transmisión en parking (P) o en neutral (N), revise el nivel de aceite de la transmisión. Inspeccione debajo del vehículo para descartar alguna fuga.
- 10) Circule en el vehículo para probar que el desempeño sea el apropiado y enseguida repita el paso anterior.

Advertencia: El aceite de transmisión automática alcanza temperaturas extremas. Déjelo enfriar antes de drenarlo.



Pide que sea 

- ✓ **Calidad de equipo original**
- ✓ **Amplia cobertura de aplicaciones**
- ✓ **Productos 100% garantizados**
- ✓ **Altamente confiables**

¿ALGUNA DUDA? **01 800 227 5634**

1.5 Filtro y empaque de transmisión automática

Automatic transmission filter kits



American Motors

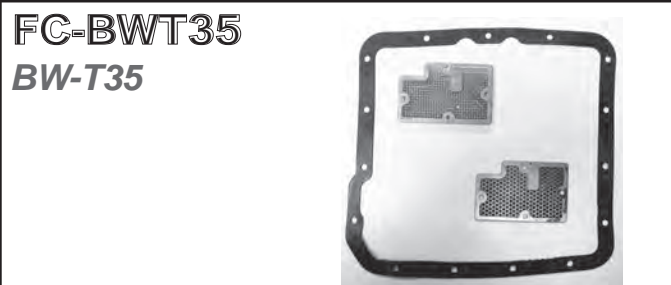

MODELO						AÑOS	
American, Super Six, Gremlin, Hornet (transmisión FLASH-O-MATIC)						62-66	
						MOTOR	
						L6, V8	
TC	15	TRACC	T	OEM	3179973	3	VEL



MODELO						AÑOS	
Custom, Deluxe, Super Six, Gremlin, Hornet, Javelin, Marlin, Matador, Rebel (transmisión FLASH-O-MATIC)						67-71	
						MOTOR	
						L6, V8	
TC	15	TRACC	T	OEM	3188896	3	VEL

BMW

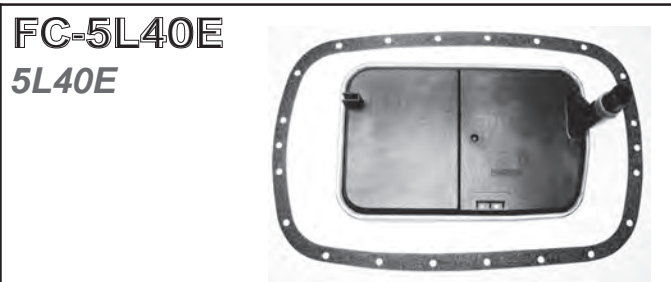

MODELO						AÑOS	
325Ci, 330Ci, 525i, 528i, 530i						00-06	
						MOTOR	
						TODOS	
TC	22	TRACC	T	OEM	24117-510-012	5	VEL

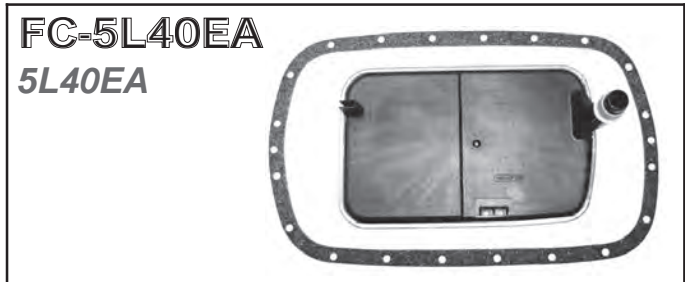

MODELO						AÑOS	
X5, Z4						00-06	
						MOTOR	
						V6	
TC	22	TRACC	T	OEM	24111-423-604	5	VEL

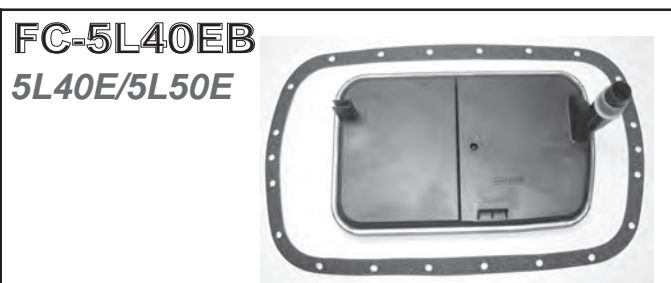

MODELO						AÑOS	
318i, Cadillac CTS, SRX						00-09	
						MOTOR	
						L4, V6	
TC	22	TRACC	T	OEM	2-4722-000	5	VEL

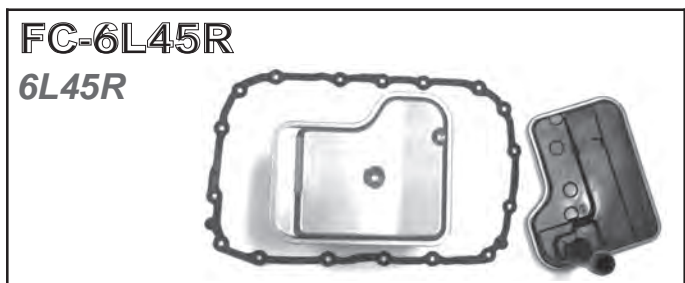

MODELO						AÑOS	
BMW X3 328i, 328Xi						06-08	
						MOTOR	
						L6	
TC	17	TRACC	T	OEM	24117-593-565	6	VEL

1.5 Filtro y empaque de transmisión automática

Automatic transmission filter kits



BMW

FC-BWT66
BW-T66



MODELO					AÑOS		
3.0CS, 3.0S, 3.0SI, Bavaria					72-76		
					MOTOR		
					L6		
TC	12	TRACC	T	OEM	4277455	3	VEL

FC-ZF3HP22
ZF3HP22



MODELO					AÑOS		
3.0SI, 318i, 318ic, 318is, 318ti, 320i					76-84		
					MOTOR		
					L4, V6		
TC	N/R	TRACC	T	OEM	24231-209-747	3	VEL

FC-ZF4HP22
ZF4HP22, ZF4HP24

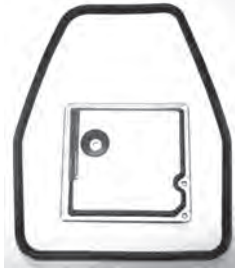

MODELO					AÑOS		
325, 325e					84-91		
					MOTOR		
					V6		
TC	NR	TRACC	T	OEM	E4LY-7A098-A	4	VEL

FC-ZF5HP18
ZF5HP18



MODELO					AÑOS		
530i, M3					93-96		
					MOTOR		
					L6		
TC	N/R	TRACC	T	OEM	24341-219-631	5	VEL

FC-ZF5HP30
ZF5HP30



MODELO					AÑOS		
540i, 740i, 750Li, 840ci, 850					91-01		
					MOTOR		
					V8, V12		
TC	23	TRACC	T	OEM	24341-422-419	5	VEL

FC-ZF6HP19
ZF6HP19

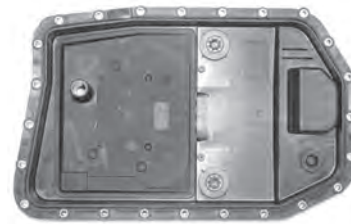

MODELO					AÑOS		
BMW X5 3.0L BMW X6 3.0L BMW Z4 Roadster 3.0L					05-08		
					MOTOR		
					L6		
TC	24	TRACC	T	OEM	24117-536-387	6	VEL

1.5 Filtro y empaque de transmisión automática Automatic transmission filter kits



BMW

FC-ZF6HP26 ZF6HP26



MODELO					AÑOS		
BMW X5 V8 4.4L, 4.8L, X6 V8 4.4L, 6 Series V8 4.4L, 4.8L, 7 Series V8 4.4L, V12 6.0L					04-08		
MOTOR					V8, V12		
TC	21	TRACC	T	OEM	24117-522-923	6	VEL

Chrysler / Dodge / Jeep

FC-42RLE 42RLE

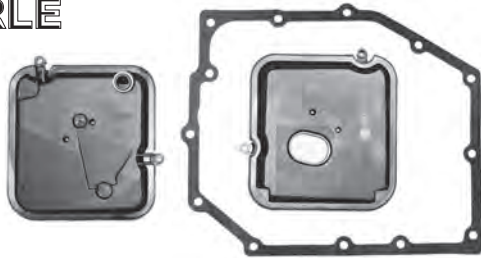

MODELO					AÑOS		
Dakota, Durango, Nitro, Challenger, 300, Charger, Jeep Liberty, Jeep Wrangler					03-09		
MOTOR					L4, L6, V6		
TC	13	TRACC	T	OEM	52852913AB	4	VEL

FC-42RLEA 42RLE

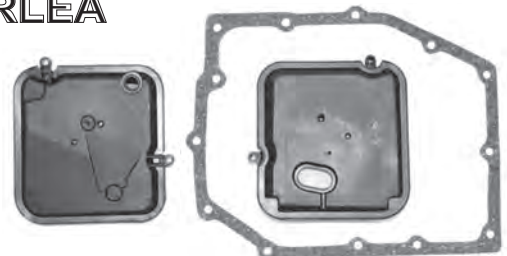

MODELO					AÑOS		
Dodge Dakota, Jeep Liberty, Dodge Charger, Jeep Wrangler					03-12		
MOTOR							
TC	13	TRACC	T	OEM	52852913AB	4	VEL

FC-44RE 42, 44, 46, 47 RE

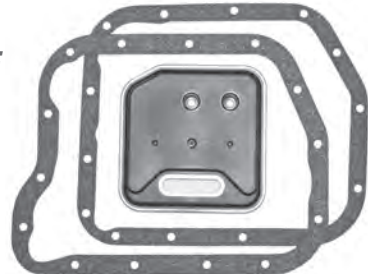

MODELO					AÑOS		
Dakota, Durango, Ram 1500, 2500, 3500					98-03		
MOTOR					V6, V8, V10		
TC	14	TRACC	T	OEM	52118789	4	VEL

FC-45RFE 45RFE, 55RFE



MODELO					AÑOS		
Jeep Grand Cherokee 4x 2, Durango, Ram 1500, 2500, 3500 (2WD)					99-11		
MOTOR					V6, V8		
TC	15	TRACC	D	OEM	4800029AA	4	VEL

1.5 Filtro y empaque de transmisión automática

Automatic transmission filter kits



Chrysler / Dodge / Jeep

FC-45RFE4
45RFE, 55RFE



MODELO						AÑOS	
Jeep Grand Cherokee 4 x 4, Durango, Ram 1500, 2500, 3500 (4WD)						99-09	
						MOTOR	
TC	15	TRACC	D	OEM	4799507	4	VEL

FC-45RFECA
45RFE, 545RFE



MODELO						AÑOS	
Todos los modelos Chrysler, Dodge, Jeep con trans. 45RFE y 545RFE						99-11	
						MOTOR	
TC	NR	TRACC	T	OEM	4799662	4 y 5	VEL

FC-62TE
62TE



MODELO						AÑOS	
Avenger, Journey, Pacifica, Caravan, Town & Country, Voyager						07-10	
						MOTOR	
TC	12	TRACC	D/AWD	OEM	05078555AA	6	VEL

FC-A404F
A-404 DACRON

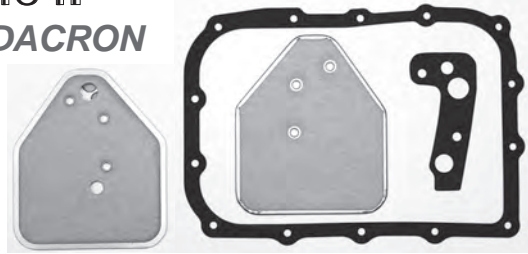

MODELO						AÑOS	
Dart K, Volare K, Lebaron						78-82	
						MOTOR	
TC	14	TRACC	D	OEM	4207219	3	VEL

FC-A404M
A-404-413-470

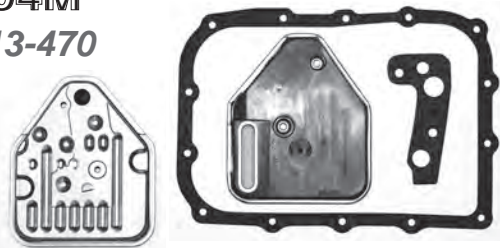

MODELO						AÑOS	
Neón, Shadow, Spirit						87-02	
						MOTOR	
TC	14	TRACC	D	OEM	4207219	3	VEL

FC-A4AF
A4B-F3



MODELO						AÑOS	
Verna by Dodge, Hyundai 1.6L y 1.8L						00-06	
						MOTOR	
TC	13	TRACC	D	OEM	46321-22731	4	VEL

1.5 Filtro y empaque de transmisión automática

Automatic transmission filter kits



Chrysler / Dodge / Jeep

FC-A604
A-604



MODELO						AÑOS	
Spirit, Shadow, Caravan, Voyager, Grand Voyager, Stratus, PT Cruiser						89-09	
						MOTOR	
						L4, V6	
TC	14	TRACC	D	OEM	4504048	4	VEL

FC-A606
A-606, 42LE



MODELO						AÑOS	
Chrysler 300M, Concorde, Intrepid						93-04	
						MOTOR	
						V6	
TC	13	TRACC	D	OEM	4626449	4	VEL

FC-A727
A904, A727

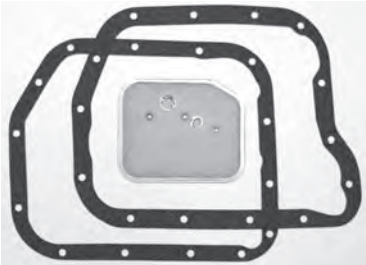

MODELO						AÑOS	
Chrysler, Dodge, Plymouth (autos y pick ups) trans. A904 y A727 (small filter)						63-72	
						MOTOR	
						L6, V8	
TC	14	TRACC	T	OEM	3621456	3	VEL

FC-A904
TF6/A904

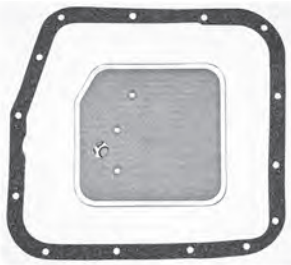

MODELO						AÑOS	
Chrysler, Dodge, Plymouth con trans. TF6 "baby A904" (empaque de cárter corto),						74-92	
						MOTOR	
						L6	
TC	14	TRACC	T	OEM	3515996	3	VEL

FC-AW4
AW4, AW30LE



MODELO						AÑOS	
Jeep Grand Cherokee, Wagoneer						87-01	
						MOTOR	
						L6, V6	
TC	19	TRACC	T	OEM	83504032	4	VEL

FC-KM170
KM170



MODELO						AÑOS	
Challenger, Colt, Champ						79-82	
						MOTOR	
						L4	
TC	12	TRACC	D	OEM	MD707786	4	VEL

1.5 Filtro y empaque de transmisión automática

Automatic transmission filter kits



Chrysler / Dodge / Jeep

FC-KM177
KM171 / KM177



MODELO					AÑOS		
Dodge Colt, Colt Vista, Eagle 2000 GTX, Eagle Summit					87-94		
					MOTOR		
					L4		
TC	12	TRACC	D	OEM	MD729954	4	VEL

FC-TF6/8
T/F 727, 904

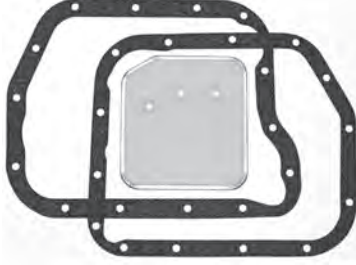

MODELO					AÑOS		
Chrysler, AMC					74-98		
					MOTOR		
					V6, V8		
TC	14	TRACC	T	OEM	3515996	3	VEL

FC-TF6CH
T/F 6-904



MODELO					AÑOS		
Chrysler, AMC					62-92		
					MOTOR		
					V6		
TC	14	TRACC	T	OEM	3621456	3	VEL

FC-TF6G
TF6-904



MODELO					AÑOS		
Chrysler, AMC					66-98		
					MOTOR		
					L6		
TC	14	TRACC	T	OEM	3515996	3	VEL

FC-TF8
T/F 8-727



MODELO					AÑOS		
Chrysler, AMC					74-98		
					MOTOR		
					L6		
TC	14	TRACC	T	OEM	3410523	3	VEL

FC-TF8CH
TF8



MODELO					AÑOS		
Chrysler, Dodge, Plymouth (autos y pick ups) (62-66), (small filter)					62-66		
					MOTOR		
					L6, V8		
TC	14	TRACC	T	OEM	2466849	3	VEL

1.5 Filtro y empaque de transmisión automática Automatic transmission filter kits



Chrysler / Dodge / Jeep

FC-W5A580
W5A580 / 722.6



MODELO		AÑOS					
Charger, SRT, Challenger, Nitro, Chrysler 300C, Magnum, Sprinter Van		05-09					
		MOTOR					
		V6, V8					
TC	6	TRACC	T	OEM	140-277-0095	5	VEL

FC-ZF4HP14
ZF4HP14



MODELO		AÑOS					
Dodge Monaco, Eagle Premier		88-92					
		MOTOR					
		V6					
TC	N/R	TRACC	D	OEM	1036-226-013	4	VEL

Ford

FC-4EAT
4EAT-F/ F4A-EL

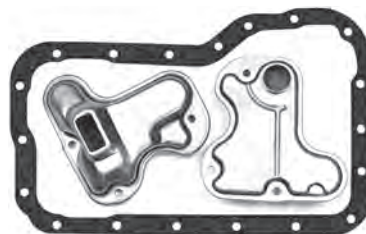

MODELO		AÑOS					
Escort, Escort ZX2		91-03					
		MOTOR					
		L4					
TC	19	TRACC	D	OEM	FU61-21-500B	4	VEL

FC-4EATG
4EAT-G, G4A-HL
Filtro de 0.625" alto



MODELO		AÑOS					
Probe, Mazda 626 Turbo		88-92					
		MOTOR					
		L4, V6					
TC	17	TRACC	D	OEM	E92Z-7A098-A	4	VEL

FC-4EATGN
4EAT-G, GF4A-EL



MODELO		AÑOS					
Probe, Mazda 626		93-97					
		MOTOR					
		L4, V6					
TC	17	TRACC	D	OEM	F32Z-7A098-A	4	VEL

FC-4F27E
4F27E (J39A)



MODELO		AÑOS					
Focus, Mazda, Ecosport		00-08					
		MOTOR					
		L4					
TC	20	TRACC	D	OEM	XS4Z-7A098-AB	4	VEL

1.5 Filtro y empaque de transmisión automática

Automatic transmission filter kits



Ford

FC-5R110W
5R110W



MODELO		AÑOS					
Pick ups Serie F, Super Duty, Excursion		03-07					
		MOTOR					
		V8					
TC	20	TRACC	T	OEM	3C3Z-7A098-AA	5	VEL

FC-5R110WCA
5R110W



MODELO		AÑOS					
Ford F-250, F-350, F-450, F-550, Excursion, E-250, E-350		03-06					
		MOTOR					
		V8, V10					
TC	N/R	TRACC	T	OEM	3C3Z-7B155-BA	5	VEL

FC-5R110WN
5R110W



MODELO		AÑOS					
Ford Super Duty F-Series		08-12					
		MOTOR					
		V8 Diesel/V10					
TC	20	TRACC	T	OEM	8C3Z-7A098-D	5	VEL

FC-5R55N
5R55N



MODELO		AÑOS					
Lincoln LS, Jaguar S Type, Jaguar X Type		00-02					
		MOTOR					
		V8					
TC	16	TRACC	T	OEM	WX4Z-7A098-BB	5	VEL

FC-5R55S
5R55S



MODELO		AÑOS					
Mustang, Thunderbird		03-09					
		MOTOR					
		V8					
TC	16	TRACC	T	OEM	3W4Z-7A098AB	5	VEL

FC-5R55W
5R55W



MODELO		AÑOS					
Mercury Mountaineer, Lincoln Aviator, Ford Explorer		02-05					
		MOTOR					
		L6, V8					
TC	16	TRACC	D	OEM	1L2Z-7A098AC	5	VEL

1.5 Filtro y empaque de transmisión automática

Automatic transmission filter kits



Ford

FC-6F35
6F35



MODELO						AÑOS	
Ford Edge, Escape, Fusion						07-14	
						MOTOR	
						V6	
TC	N / R	TRACC	D/AWD	OEM	9L8P-7G186-CD	6	VEL

FC-6R60
6R60



MODELO						AÑOS	
Ford Explorer, Mercury Mountaineer						06-08	
						MOTOR	
						V8	
TC	21	TRACC	T	OEM	6L2P-7G186-AA	6	VEL

FC-6T70
6F50N / 6F55



MODELO						AÑOS	
Ford Edge, Taurus, Taurus X, Mercury Sable, Lincoln MKS						07-09	
						MOTOR	
						V6	
TC	N / R	TRACC	D/AWD	OEM	7T4Z-7A098-B	6	VEL

FC-A4LD
A4LD 4WD



MODELO						AÑOS	
Aerostar, Explorer, Ranger (4WD)						86-94	
						MOTOR	
						L4, V6	
TC	18	TRACC	T	OEM	E6TZ-7A098-A	4	VEL

FC-A4LDA
A4LD 2WD

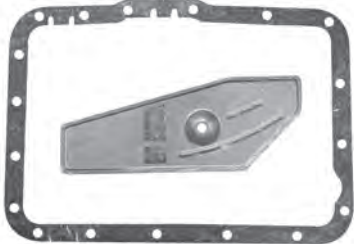

MODELO						AÑOS	
Bronco II, Ranger						85-88	
						MOTOR	
						L4, V6	
TC	18	TRACC	T	OEM	E6TZ-7A098B	4	VEL

FC-A4LDE
4R44E, 5R44E



MODELO						AÑOS	
Explorer, Ranger, Mazda Pick Up B2300 (2WD)						95-06	
						MOTOR	
						L4, V6	
TC	18	TRACC	T	OEM	E9TZ-7A098-C	4	VEL

1.5 Filtro y empaque de transmisión automática

Automatic transmission filter kits



Ford

FC-A4LDE4
4R55E, 5R55E



MODELO						AÑOS	
Explorer, Ranger, Mazda Pick Ups (4WD)						95-06	
						MOTOR	
						L4, V6	
TC	14	TRACC	T	OEM	3621456	4	VEL

FC-A4LDR
A4LD

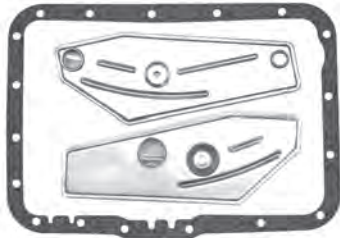

MODELO						AÑOS	
Aerostar, Explorer, Ranger						89-95	
						MOTOR	
						L4, V6	
TC	18	TRACC	T	OEM	E9TZ-7A098-C	4	VEL

FC-ATX
ATX



MODELO						AÑOS	
Topaz, Tempo, Sable, Taurus, Escort						81-94	
						MOTOR	
						L4	
TC	13	TRACC	D	OEM	E1EZ-7A098A	3	VEL

FC-AX4N
AX4N/AX4S



MODELO						AÑOS	
Taurus, Sable (sello verde)						96-06	
						MOTOR	
						V6	
TC	19	TRACC	D	OEM	F6DZ-7A098-A	4	VEL

FC-AX4S
AX4S



MODELO						AÑOS	
Lincoln Continental, Ford Windstar (sello naranja alto)						94-06	
						MOTOR	
						V8	
TC	17	TRACC	D	OEM	F5DZ-7A098-A	4	VEL

FC-AXOD
AXODE



MODELO						AÑOS	
Taurus, Sable, Windstar (sello naranja bajo)						91-01	
						MOTOR	
						V6	
TC	17	TRACC	D	OEM	E6DZ-7A098-A	4	VEL

1.5 Filtro y empaque de transmisión automática

Automatic transmission filter kits



Ford

FC-AXODA
AXOD



MODELO		AÑOS					
Taurus, Sable (tipo viejo)		86-90					
		MOTOR					
		V6					
TC	17	TRACC	D	OEM	E6DZ-7A098-A	3	VEL

FC-C3
C3



MODELO		AÑOS					
Fairmont, Mustang, Thunderbird		74-86					
		MOTOR					
		L4, V6					
TC	13	TRACC	T	OEM	D4ZZ-7A098-A	3	VEL

FC-C4
C4



MODELO		AÑOS					
Fairmont, Pick Ups F-100, Mustang		70-82					
		MOTOR					
		L4, L6, V8					
TC	11	TRACC	T	OEM	D0DZ-7A098-B	3	VEL

FC-C4A
C4



MODELO		AÑOS					
Ford, Mercury automóviles, Pick Ups, Vans		65-70					
		MOTOR					
		V6, V8					
TC	11	TRACC	T	OEM	D0DZ-7A098-B	3	VEL

FC-C4D
C4 (4WD)



MODELO		AÑOS					
Ford Bronco, Pick up F-100, F-150 (4WD)		70-82					
		MOTOR					
		L6, V8					
TC	11	TRACC	T	OEM	D3BZ-7A098-A	3	VEL

FC-C4N
C4



MODELO		AÑOS					
Ford Fairmont, Mustang, Pinto		74-80					
		MOTOR					
		L4, V6					
TC	11	TRACC	T	OEM	D4FZ-7A098-A	3	VEL

1.5 Filtro y empaque de transmisión automática

Automatic transmission filter kits



Ford

FC-C5
C5



MODELO		AÑOS
Cougar, Thunderbird , Pick Ups F-100, F-150		82-86
		MOTOR
		L4, V6

TC	11	TRACC	T	OEM	E2AZ-7A098-A	3	VEL
----	----	-------	---	-----	--------------	---	-----

FC-C54
C5 (4WD)



MODELO		AÑOS
Pick Ups F-100, F-150 (4WD)		82-86
		MOTOR
		V6, V8

TC	11	TRACC	T	OEM	E3TZ-7A098-A	3	VEL
----	----	-------	---	-----	--------------	---	-----

FC-C6
C6



MODELO		AÑOS
Bronco, Pick Up F-100, F-150 (4WD)		73-96
		MOTOR
		V8

TC	17	TRACC	T	OEM	D3TZ-7A098-A	3	VEL
----	----	-------	---	-----	--------------	---	-----

FC-C6A
C6 ANTIGUO



MODELO		AÑOS
Galaxie, Pick Ups F-100		68-74
		MOTOR
		V8

TC	17	TRACC	T	OEM	C6AZ-7A098-A	3	VEL
----	----	-------	---	-----	--------------	---	-----

FC-C6E
E40D/4R100 2WD
(filtro metal/plástico)



MODELO		AÑOS
Expedition, Excursion, Lincoln Navigator, Pick ups F-150, Lobo		92-08
		MOTOR
		V8

TC	20	TRACC	T	OEM	E9TZ-7A098A	4	VEL
----	----	-------	---	-----	-------------	---	-----

FC-C6EP
E40D / 4R100 /2WD
(filtro de plástico)



MODELO		AÑOS
Ford F-150, F-250, F-350, Expedition, 2WD		92-08
		MOTOR
		V8

TC	20	TRACC	T	OEM	YC3Z-7A098-AA	4	VEL
----	----	-------	---	-----	---------------	---	-----

1.5 Filtro y empaque de transmisión automática

Automatic transmission filter kits



Ford

FC-C6N
C6 RECIENTE



MODELO		AÑOS					
Pick ups F-100, F-150, LTD, Mercury Marquis		75-96					
		MOTOR					
		V6, V8					
TC	17	TRACC	T	OEM	D5AZ-7A098-AA	3	VEL

FC-CD4E
CD4E



MODELO		AÑOS					
Contour, Mystique, Escape , Probe (2WD, 4WD)		95-06					
		MOTOR					
		L4					
TC	14	TRACC	D	OEM	F3RZ-7A098-A	4	VEL

FC-CFT23
CVT



MODELO		AÑOS					
Ford Focus C-Max		03-10					
		MOTOR					
		L4					
TC	N/R	TRACC	D	OEM	0501-214-113	CVT	VEL

FC-CFT30
CFT30



MODELO		AÑOS					
Ford Five Hundred, Freestyle, Mercury Montego		05-07					
		MOTOR					
		V6					
TC	22	TRACC	D/AWD	OEM	5F9Z-7A098A	CVT	VEL

FC-E4OD4W
E4OD/4R100 4WD
(filtro metal/plástico)



MODELO		AÑOS					
Expedition, Excursion, Lincoln Navigator Pick ups F-150, F-250, Lobo		92-08					
		MOTOR					
		V8					
TC	20	TRACC	T	OEM	E9TZ-7A098B	4	VEL

FC-E4OD4WP
EOD/ 4R100 (4WD)
(filtro de plástico)



MODELO		AÑOS					
Lobo, Expedition, Lincoln Navigator Pick ups F-150, F-250, Lobo		92-08					
		MOTOR					
		V6, V8					
TC	20	TRACC	T	OEM	F6TZ-7A098-BB		VEL

1.5 Filtro y empaque de transmisión automática

Automatic transmission filter kits



Ford

FC-F3A
F3A



MODELO					AÑOS		
Mercury Tracer					87-90		
					MOTOR		
					L4		
TC	18	TRACC	T	OEM	E7GZ-7A098-A	3	VEL

FC-F3AATX

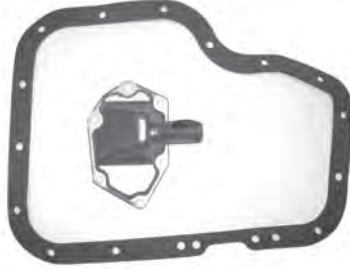

MODELO					AÑOS		
Aspire					94-97		
					MOTOR		
					L4		
TC	18	TRACC	D	OEM	F4BZ-7A098-A	3	VEL

FC-F3AE
F3A / MX1



MODELO					AÑOS		
Ford Festiva, Mercury Tracer					87-93		
					MOTOR		
					L4		
TC	18	TRACC	D	OEM	E7GZ-7A098-A	3	VEL

FC-F3AF
F3A



MODELO					AÑOS		
Ford Festiva					89-93		
					MOTOR		
					L4		
TC	18	TRACC	D	OEM	E9BZ-7A098-A	3	VEL

FC-FIOD
AOD (2WD)



MODELO					AÑOS		
Cougar, Thunderbird, Grand Marquis, Bronco, Pick ups F-100, F-150 (2WD), Vans Serie "E" (2WD)					81-92		
					MOTOR		
					V6, V8		
TC	14	TRACC	T	OEM	E1AZ-7A098-A	4	VEL

FC-FIOD4
AOD (4WD)

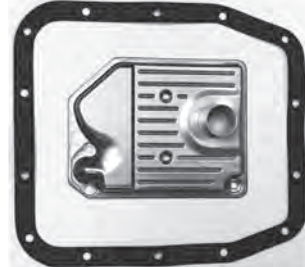

MODELO					AÑOS		
Pick F-100, F-150, Bronco (4WD)					81-92		
					MOTOR		
					V6, V8		
TC	14	TRACC	T	OEM	E5TZ-7A098-C	4	VEL

1.5 Filtro y empaque de transmisión automática

Automatic transmission filter kits



Ford

FC-FIOD4E
AODE (4R70W)



MODELO						AÑOS	
Explorer (4WD), Expedition, Lobo, Pick ups F-150, F-250 (4WD)						93-10	
						MOTOR	
						V6, V8	
TC	14	TRACC	T	OEM	F4TZ-7A098-A	4	VEL

FC-FIODE
AODE (4R70W)



MODELO						AÑOS	
Grand Marquis, Cougar, Thunderbird, Pick up F-150, Lobo (2WD)						93-10	
						MOTOR	
						V6, V8	
TC	14	TRACC	T	OEM	F2VY-7A098-A	4	VEL

FC-FMX
FMX (LATON)



MODELO						AÑOS	
Galaxie, LTD, Mustang						68-79	
						MOTOR	
						V6, V8	
TC	14	TRACC	T	OEM	D0AZ-7A098-A	3	VEL

FC-FMXF
FMX (FELPA)



MODELO						AÑOS	
Ford LTD, Mustang, Mercury Marquis						69-81	
						MOTOR	
						V8	
TC	14	TRACC	T	OEM	D8AZ-7A098-AB	3	VEL

FC-FNR5
FNR5



MODELO						AÑOS	
Ford Fusion, Lincoln Zephyr, Mercury Milan						06-08	
						MOTOR	
						L4, V6	
TC	20	TRACC	D	OEM	FNC1-21-500	5	VEL

FC-G4AHL
G4A-HL
(1.250" ALTO)



MODELO						AÑOS	
Ford Probe, Mercury Capri, Mazda 323						88-92	
						MOTOR	
						L4	
TC	17	TRACC	D	OEM	FU50-21-500A	4	VEL

1.5 Filtro y empaque de transmisión automática

Automatic transmission filter kits



Ford

FC-JF506E
JF506E



MODELO		AÑOS
Ford Mondeo		03-06
		MOTOR
		V6

TC	20	TRACC	D	OEM	6L2P-7G186-AA	5	VEL
----	----	-------	---	-----	---------------	---	-----

FC-TF81SC
AWTF81SC



MODELO		AÑOS
Ford Fusion, Five Hundred, Freestyle, Mercury Milan, Montego, Mariner		05-09
		MOTOR
		L4, V6

TC	12	TRACC	D/AWD	OEM	60-27-0F099-0080	6	VEL
----	----	-------	-------	-----	------------------	---	-----

General Motors

FC-4L30E
4L30E



MODELO		AÑOS
GM Pick Ups Luv		90-06
		MOTOR
		L4

TC	16	TRACC	T	OEM	8-96015-062-0	4	VEL
----	----	-------	---	-----	---------------	---	-----

FC-4L30E6
4L30E



MODELO		AÑOS
Cadillac Catera, BMW		97-01
		MOTOR
		V6

TC	16	TRACC	T	OEM	96015431	4	VEL
----	----	-------	---	-----	----------	---	-----

FC-4L60E
4L60E



MODELO		AÑOS
Corvette		97-04
		MOTOR
		V8

TC	16	TRACC	T	OEM	24207600	4	VEL
----	----	-------	---	-----	----------	---	-----

FC-4L60EA
4L60E

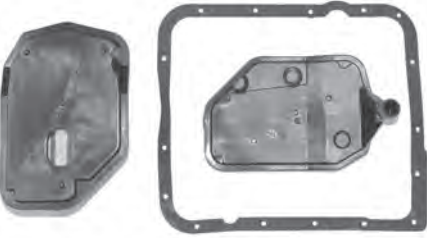

MODELO		AÑOS
Colorado, GMC Canyon, Hummer H3		04-09
		MOTOR
		V6

TC	16	TRACC	T	OEM	24225323	4	VEL
----	----	-------	---	-----	----------	---	-----

1.5 Filtro y empaque de transmisión automática

Automatic transmission filter kits



General Motors

FC-4L60EB
4L60E

MODELO						AÑOS	
Cheyenne, Silverado, Suburban, Tahoe, Sonora						03-10	
						MOTOR	
						V8	
TC	16	TRACC	T	OEM	24208813	4	VEL

FC-4L80E
4L80E

MODELO						AÑOS	
Suburban, Pick ups						91-96	
						MOTOR	
						V8	
TC	17	TRACC	T	OEM	8678757	4	VEL

FC-4L80ER2
4L80E

MODELO						AÑOS	
Suburban, Avalanche 2500, Pick Ups 2500, 3500 Express Van 2500, 3500						97-10	
						MOTOR	
						V8	
TC	17	TRACC	T	OEM	24204277	4	VEL

FC-4T40E
4T40E

MODELO						AÑOS	
Chevrolet Cavalier, Malibu, Pontiac Sunfire, Grand Am,						95-05	
						MOTOR	
						L4, V6	
TC	12	TRACC	D	OEM	24221762	4	VEL

FC-4T45E
4T45E

MODELO						AÑOS	
Buick Lacrosse, Lacrosse II						06-14	
						MOTOR	
						V6	
TC	12	TRACC	D	OEM	24221762	4	VEL

FC-4T80E
4T80E

MODELO						AÑOS	
Cadillac DeVille, Seville						93-04	
						MOTOR	
						V8	
TC	16	TRACC	D	OEM	8681416	4	VEL

1.5 Filtro y empaque de transmisión automática

Automatic transmission filter kits



General Motors

FC-4T80E2
4T80E



MODELO						AÑOS	
Cadillac De Ville , Seville						93-04	
						MOTOR	
						V8	
TC	16	TRACC	D	OEM	8681416	4	VEL

FC-4W60
AW60-40LE



MODELO						AÑOS	
Chevy, Chevy Monza, Astra, Saab 9-3, 9-5						99-10	
						MOTOR	
						L4	
TC	12	TRACC	D	OEM	26445-60G10	4	VEL

FC-6L80
6L80



MODELO						AÑOS	
Silverado, Sierra, Suburban, Tahoe, Yukon, Corvette, Avalanche, Escalade						06-09	
						MOTOR	
						V8	
TC	18	TRACC	T	OEM	24236933	6	VEL

FC-6L80E
6L80E



MODELO						AÑOS	
Cadillac ATS (13-14), Chevrolet Caprice, Pontiac G8						08-14	
						MOTOR	
						V8	
TC	18	TRACC		OEM	24235900	6	VEL

FC-6L90
6L90



MODELO						AÑOS	
Tahoe, Yukon, Silverado, Suburban						07-12	
						MOTOR	
						V8	
TC	18	TRACC	T	OEM	24236933	6	VEL

FC-6T40E
6T40E



MODELO						AÑOS	
Chevrolet Malibu, Cruze, Captiva, Buick LaCrosse						08-14	
						MOTOR	
						L4	
TC	17	TRACC	D	OEM	24230708	6	VEL

1.5 Filtro y empaque de transmisión automática

Automatic transmission filter kits



General Motors

FC-6T70
6T70E / 6T75E



MODELO					AÑOS		
Acadia, Equinox Sport, Malibu, Traverse, Sonic Buick LaCrosse					07-09		
					MOTOR		
					V6		
TC	NR	TRACC	D / AWD	OEM	24223670	6	VEL

FC-A43DE
A43DE



MODELO					AÑOS		
Geo Tracker					96-98		
					MOTOR		
					Todos		
TC	14	TRACC	T	OEM	26582-57800	4	VEL

FC-AW55
AW55-50SN



MODELO					AÑOS		
Chevrolet Equinox, Pontiac Torrent					05-09		
					MOTOR		
					V6		
TC	NR	TRACC	D / T	OEM	24220578	5	VEL

FC-AW81
AW81-40LE / ML4



MODELO					AÑOS		
Chevrolet Aveo, Pontiac Wave Pontiac G3					07-17		
					MOTOR		
					L4		
TC	18	TRACC	D	OEM	93741509	4	VEL

FC-F3AG
F3A



MODELO					AÑOS		
Geo Spectrum					85-88		
					MOTOR		
					L4		
TC	18	TRACC	D	OEM	94140860	3	VEL

FC-JF403E
JF403E



MODELO					AÑOS		
Geo Storm, Isuzu Impulse					90-93		
					MOTOR		
					L4		
TC	21	TRACC	D	OEM	94385937	4	VEL

1.5 Filtro y empaque de transmisión automática

Automatic transmission filter kits



General Motors

FC-MX1
MX1, F3A



MODELO						AÑOS	
Geo Spectrum, Isuzu Stylus						85-93	
						MOTOR	
						L4	
TC	18	TRACC	D	OEM	94428489	3	VEL

FC-MX17
MX17, MX1



MODELO						AÑOS	
GEO Metro, Suzuki Swift						89-01	
						MOTOR	
						L3, L4	
TC	15	TRACC	D	OEM	96053975	3	VEL

FC-PWRGLIDE
POWERGLIDE

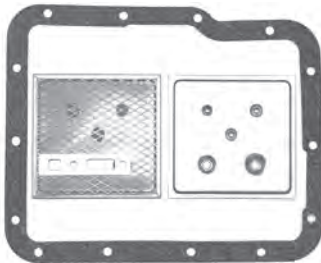

MODELO						AÑOS	
Bel-Air, Camaro, Chevelle, Impala, Pick up C-10						63-73	
						MOTOR	
						V8	
TC	14	TRACC	T	OEM	6438815	2	VEL

FC-TAAT
TAAT



MODELO						AÑOS	
Saturn S series						91-01	
						MOTOR	
						L4	
TC	NR	TRACC	D	OEM	21002496	4	VEL

FC-TAATCA
TAAT



MODELO						AÑOS	
Todos los modelos Cartucho GM Silverado, Saturn						91-01	
						MOTOR	
						Todos	
TC	NR	TRACC	D	OEM	21002303	4	VEL

FC-TH125
TH-125C/3T40



MODELO						AÑOS	
Chevrolet, Buick, Isuzu, Oldsmobile, Pontiac						80-02	
						MOTOR	
						L4	
TC	16	TRACC	D	OEM	25010991	3	VEL

1.5 Filtro y empaque de transmisión automática

Automatic transmission filter kits



General Motors

FC-TH180
TH-180 (3L30)



MODELO		AÑOS					
Geo Tracker 2WD, 4WD, Chevette, Pick Up Luv		72-98					
		MOTOR					
		L4, V6					
TC	12	TRACC	T	OEM	26950-61-A00	3	VEL

FC-TH200L
TH-200



MODELO		AÑOS					
Malibu, Impala		77-79					
		MOTOR					
		V6, V8					
TC	11	TRACC	T	OEM	8628299	3	VEL

FC-TH200NY
TH-200C

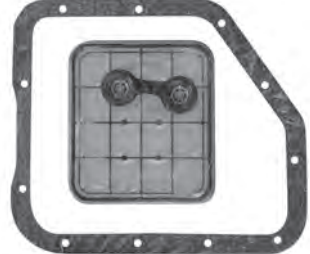

MODELO		AÑOS					
S-10 Pick Ups, Pick Up Isuzu, Caprice, Malibu		79-85					
		MOTOR					
		V6, V8					
TC	11	TRACC	T	OEM	8630789	3	VEL

FC-TH200R4
TH-2004R



MODELO		AÑOS					
Malibú, Caprice, Impala, Monte Carlo		81-90					
		MOTOR					
		V6, V8					
TC	16	TRACC	T	OEM	8629951	4	VEL

FC-TH325
TH325



MODELO		AÑOS					
Cadillac Seville, Oldsmobile Toronado		79-81					
		MOTOR					
		V8					
TC	14	TRACC	D	OEM	8632630	3	VEL

FC-TH325N
TH325-4L



MODELO		AÑOS					
Buick Riviera, Cadillac El Dorado, Cadillac Seville, Oldsmobile Toronado		82-85					
		MOTOR					
		V6, V8					
TC	15	TRACC	D	OEM	8365710	4	VEL

1.5 Filtro y empaque de transmisión automática

Automatic transmission filter kits



General Motors

FC-TH350C
TH350
TH350C
TH375B



MODELO						AÑOS	
Buick Century, Regal, Caprice, Impala						75-83	
						MOTOR	
						V6, V8	
TC	13	TRACC	T	OEM	8641910	3	VEL

FC-TH350L
TH-350

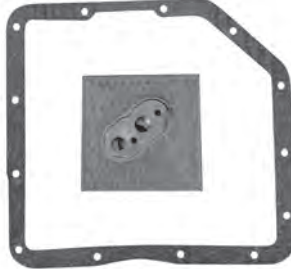

MODELO						AÑOS	
Pick ups C-10, Caprice, Impala, Malibu (malla de latón)						69-86	
						MOTOR	
						V6, V8	
TC	13	TRACC	T	OEM	6261412	3	VEL

FC-TH350NY
TH-350

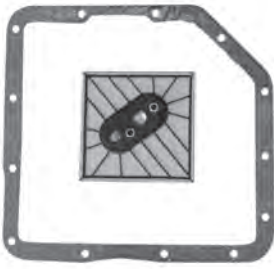

MODELO						AÑOS	
Pick ups C-10, Caprice, Impala, Malibu (malla de nylon)						69-86	
						MOTOR	
						V6, V8	
TC	13	TRACC	T	OEM	8640848	3	VEL

FC-TH400
TH-400 / 3L80
(FELPA)



MODELO						AÑOS	
GM Pick ups C-10, C-20, C-30, Suburban						68-90	
						MOTOR	
						V8	
TC	13	TRACC	T	OEM	6437741	3	VEL

FC-TH400A
TH400 (ANTIGUO)



MODELO						AÑOS	
GM autos y pick ups						64-67	
						MOTOR	
						L6, V8	
TC	13	TRACC	T	OEM	5579822	3	VEL

FC-TH400L
TH400 (LATON)



MODELO						AÑOS	
GM autos y pick ups (malla de latón)						68-90	
						MOTOR	
						L6, V8	
TC	13	TRACC	T	OEM	6437741	3	VEL

1.5 Filtro y empaque de transmisión automática

Automatic transmission filter kits



General Motors

FC-TH425
TH425 (M40E)



MODELO					AÑOS		
Cadillac El Dorado, Oldsmobile Toronado					67-78		
					MOTOR		
					V8		
TC	13	TRACC	D	OEM	6435766	3	VEL

FC-TH440N
4T60



MODELO					AÑOS		
Century, Cutlass, Celebrity					84-94		
					MOTOR		
TC	19	TRACC	D	OEM	8689918	4	VEL

FC-TH700A
TH700 R4



MODELO					AÑOS		
Caprice, Impala					82-87		
					MOTOR		
					V6, V8		
TC	16	TRACC	T	OEM	8634223	4	VEL

FC-TH700E
4L60E

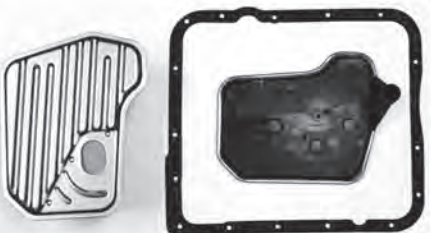

MODELO					AÑOS		
Suburban, Pick Ups					93-97		
					MOTOR		
					V8		
TC	16	TRACC	T	OEM	24200796	4	VEL

FC-TH700E6
4T60E/4T65E



MODELO					AÑOS		
Buick LaCrosse, Century, Cutlass, Venture					93-09		
					MOTOR		
					V6		
TC	20	TRACC	D	OEM	8651909	4	VEL

FC-TH700E8N
4L60E



MODELO					AÑOS		
Suburban, Sonora, Express Van 1500, 2500, Silverado					98-02		
					MOTOR		
					L4, V6, V8		
TC	16	TRACC	T	OEM	24208576	4	VEL

1.5 Filtro y empaque de transmisión automática

Automatic transmission filter kits



General Motors

FC-TH700EP
4L60E
(filtro de plástico)



MODELO					AÑOS		
Cheyenne, Silverado, Suburban					93-97		
					MOTOR		
					V6, V8		
TC	16	TRACC	T	OEM	24208835	4	VEL

FC-TH700N
TH700 R4 / 4L60



MODELO					AÑOS		
Astro, Suburban, Pick ups Cheyenne , C-10, C-20, C1500					82-92		
					MOTOR		
					V6, V8		
TC	16	TRACC	T	OEM	8657926	4	VEL

FC-VT25E
CVT

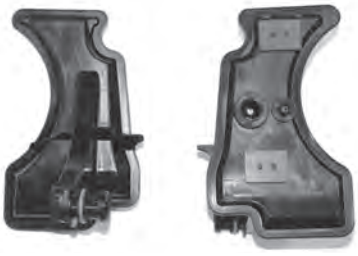

MODELO					AÑOS		
Saturn					02-06		
					MOTOR		
					L4		
TC	N/R	TRACC	D	OEM	24226576	CVT	VEL

Honda

FC-A24A
A24A, M24A



MODELO					AÑOS		
Civic, CRX					88-97		
					MOTOR		
					L4		
TC	NR	TRACC	D	OEM	25420-P24-J01	4	VEL

FC-APX4
APX4, MPJA



MODELO					AÑOS		
Accord, CRX					88-92		
					MOTOR		
					L4		
TC	NR	TRACC	D	OEM	25420-PX4-023	4	VEL

1.5 Filtro y empaque de transmisión automática Automatic transmission filter kits



Honda

FC-B7XA
B7XA



MODELO						AÑOS	
Accord, Odyssey						98-02	
						MOTOR	
						V6	
TC	NR	TRACC	D	OEM	25420-P7X-003	4	VEL

FC-B97A
B97A



MODELO						AÑOS	
Honda Accord, Pilot, Odyssey						11-12	
						MOTOR	
						V6	
TC	N / R	TRACC	D	OEM	25420-R36-003	5	VEL

FC-BAXA
BAXA

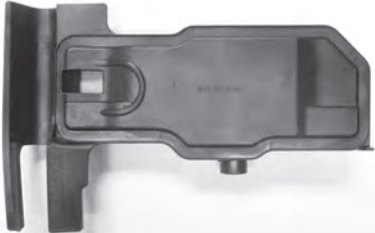

MODELO						AÑOS	
Accord, Odyssey, Prelude						97-02	
						MOTOR	
						L4	
TC	NR	TRACC	D	OEM	25420-PAX-003	4	VEL

FC-BDGA
BGRA



MODELO						AÑOS	
Honda Odyssey EX						05-09	
						MOTOR	
						V6	
TC	NR	TRACC	D	OEM	25450-RAY-003	5	VEL

FC-BDKA
BDKA

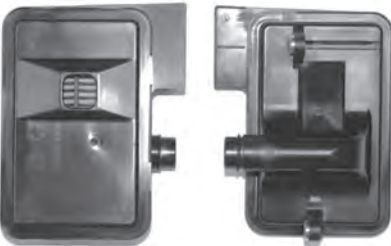

MODELO						AÑOS	
Honda Civic, Fit						06-15	
						MOTOR	
						L4	
TC	N / R	TRACC	D	OEM	25420-RPC-003	5	VEL

FC-BVLA
BVGA



MODELO						AÑOS	
Honda Pilot EX						03-09	
						MOTOR	
						V6	
TC	NR	TRACC	D/AWD	OEM	25420-RDP-003	5	VEL

1.5 Filtro y empaque de transmisión automática

Automatic transmission filter kits



Honda

FC-CVTH
CVT



MODELO		AÑOS					
Honda Civic HX		96-05					
		MOTOR					
		L4					
TC	14	TRACC	D	OEM	25420-PET-003	CVT	VEL

FC-G4
G4 / L5 / CA / AS



MODELO		AÑOS					
Accord, Civic, CRX, Prelude		83-91					
		MOTOR					
		L4					
TC	NR	TRACC	D	OEM	25420-PC9-010	4	VEL

FC-HONDA3
HONDAMATIC



MODELO		AÑOS					
Accord, Civic, Prelude		79-85					
		MOTOR					
		L4					
TC	NR	TRACC	D	OEM	25420-PA9-000	3	VEL

FC-HONDAMATIC
HONDAMATIC



MODELO		AÑOS					
Accord, Civic, CRX, Prelude		73-85					
		MOTOR					
		L4					
TC	N/R	TRACC	D	OEM	25420-639-000	2	VEL

FC-K4
K4 / MY8A / PY8A



MODELO		AÑOS					
Prelude		88-89					
		MOTOR					
		L4					
TC	NR	TRACC	D	OEM	25420-PK4-000	4	VEL

FC-M4TA
M4VA



MODELO		AÑOS					
CR-V		94-00					
		MOTOR					
		L4					
TC	NR	TRACC	D	OEM	25420-P56-003	4	VEL

1.5 Filtro y empaque de transmisión automática

Automatic transmission filter kits



Honda

FC-M4VA
M4VA (CVT)

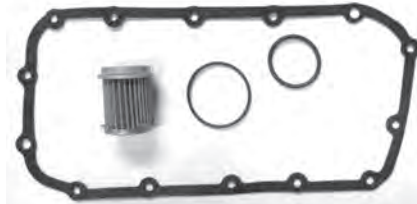

MODELO						AÑOS	
Civic						96-00	
						MOTOR	
						L4	
TC	14	TRACC	D	OEM	25450-P4V-013	4	VEL

FC-M4VAP
M4VA



MODELO						AÑOS	
Civic HX						96-00	
						MOTOR	
						L4	
TC	14	TRACC	D	OEM	25420-P4V-003	CVT	VEL

FC-M7WA
BYBA / M7WA



MODELO						AÑOS	
Odyssey						02-04	
						MOTOR	
						V6	
TC	NR	TRACC	D	OEM	25420-P7W-003	5	VEL

FC-M91A
M91A

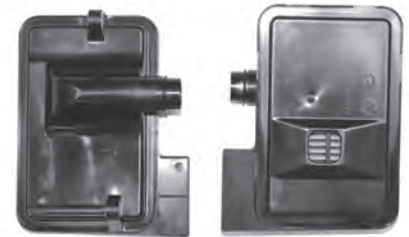

MODELO						AÑOS	
Honda Accord, CR-V, Element						07-12	
						MOTOR	
						L4	
TC	N / R	TRACC	D/AWD	OEM	25420-RXH-003	5	VEL

FC-MDLA
MDLA/MDWA



MODELO						AÑOS	
CR-V						99-03	
						MOTOR	
						L4	
TC	NR	TRACC	D	OEM	25420-P4R-013	4	VEL

FC-ML4A
ML4A



MODELO						AÑOS	
Honda CRX, Acura Integra						88-91	
						MOTOR	
						L4	
TC	N/R	TRACC	D	OEM	25420-PL4-000	4	VEL

1.5 Filtro y empaque de transmisión automática

Automatic transmission filter kits



Honda

FC-MPJACA
MPJA
(Filtro sellado)



MODELO						AÑOS	
Accord, Civic, CR-V, Odyssey, Pilot						01-07	
						MOTOR	
						V6	
TC	N/R	TRACC	D	OEM	25450-P7W-003	4	VEL

FC-MPRA
MPRA / MR9A

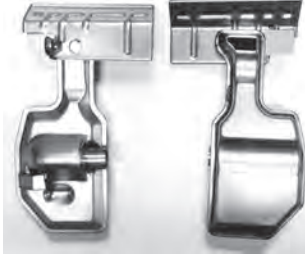

MODELO						AÑOS	
Acura NSX, Acura Integra						91-98	
						MOTOR	
						V6	
TC	N/R	TRACC	D	OEM	25420-PR9-010	4	VEL

FC-MPWA
MPWA / M1WA

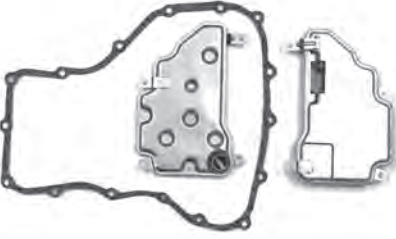

MODELO						AÑOS	
Acura TL, Vigor						92-99	
						MOTOR	
						L5	
TC	16	TRACC	D	OEM	25420-PW4-010	4	VEL

FC-MPXA
PX4B / MPXA

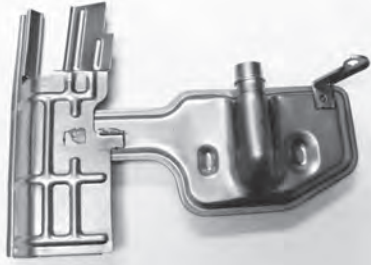

MODELO						AÑOS	
Accord, Prelude, Odyssey						91-97	
						MOTOR	
						L4	
TC	N/R	TRACC	D	OEM	25420-PX4-701	4	VEL

FC-MPYA
MPYA

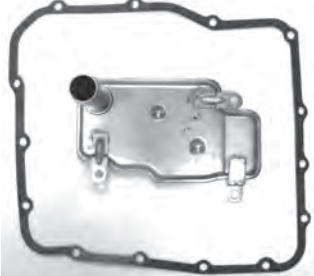

MODELO						AÑOS	
Acura Legend						91-95	
						MOTOR	
						L4	
TC	14	TRACC	D	OEM	25420-PY4-000	4	VEL

FC-MURA
MURA



MODELO						AÑOS	
Honda Accord DX, EX, (hibrido)						06-11	
						MOTOR	
						V6	
TC	N / R	TRACC	D	OEM	25420-RCK-004	5	VEL

1.5 Filtro y empaque de transmisión automática Automatic transmission filter kits



Honda

FC-MV2A
MV2A



MODELO							AÑOS	
Honda Odyssey, Accord							11-15	
							MOTOR	
							V6	
TC	N / R	TRACC	D	OEM	25420-RV2-003	6	VEL	

FC-PN3A
PN3A



MODELO							AÑOS	
Honda Pilot, Acura TL							09-14	
							MOTOR	
							V6	
TC	N / R	TRACC	T	OEM	25420-RN3-003	5	VEL	

FC-SLYA
SLYA



MODELO							AÑOS	
Civic GX, HX							01-05	
							MOTOR	
							L4	
TC	14	TRACC	D	OEM	25420-PLY-003	CVT	VEL	

FC-SMMA
SMMA



MODELO							AÑOS	
Honda Fit, Element							07-11	
							MOTOR	
							L4	
TC	N / R	TRACC	D	OEM	25420-PWR-003	5	VEL	

FC-SMMACA
SMMA



MODELO							AÑOS	
Honda Fit, Honda Element (cartucho)							07-11	
							MOTOR	
							L4	
TC	N / R	TRACC	D	OEM	25450-PWR-003	5	VEL	

FC-SPCA
SPCA

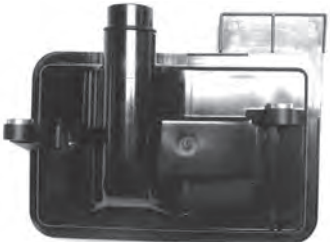

MODELO							AÑOS	
Civic							06-09	
							MOTOR	
							L4	
TC	N/R	TRACC	D	OEM	25420-RPC-003	5	VEL	

1.5 Filtro y empaque de transmisión automática

Automatic transmission filter kits



Honda

FC-SZCA
CVT



MODELO					AÑOS		
Honda Civic (hibrido)					03-09		
					MOTOR		
					L4		
TC	N / R	TRACC	D	OEM	25420-PHT-003	CVT	VEL

Hyundai

FC-A4AF1
F4A32



MODELO					AÑOS		
Accent, Elantra, Tiburon, Scoupe					93-99		
					MOTOR		
					L4		
TC	13	TRACC	D	OEM	46321-22050	4	VEL

FC-F4A21
F4A32



MODELO					AÑOS		
Accent, Scoupe					93-99		
					MOTOR		
					L4		
TC	13	TRACC	D	OEM	46321-22731	4	VEL

FC-KM177
KM171 / KM177



MODELO					AÑOS		
Hyundai Excel					87-94		
					MOTOR		
					L4		
TC	12	TRACC	D	OEM	MD729954	4	VEL

FC-F4A51T
F4A32 / F4A42
F4A51 / F5A51



MODELO					AÑOS		
Accent , Elantra, Sonata, Tiburon, XG300, Santa Fe, Tucson					95-13		
					MOTOR		
					L4, V6		
TC	15	TRACC	T	OEM	46321-39010	5	VEL

1.5 Filtro y empaque de transmisión automática

Automatic transmission filter kits



Isuzu

FC-4L30E
4L30E



MODELO						AÑOS	
Amigo, Rodeo, Trooper, Pick up Luv						91-06	
						MOTOR	
						V-6	
TC	16	TRACC	T	OEM	8-96015-062-0	4	VEL

FC-AW450
AW450-43LE



MODELO						AÑOS	
Isuzu Truck NPR						98-06	
						MOTOR	
						L4	
TC	20	TRACC	T	OEM	8-97202-067-0	4	VEL

FC-F3AG
F3A



MODELO						AÑOS	
Isuzu I-Mark						85-89	
						MOTOR	
						L4	
TC	18	TRACC	D	OEM	94413320	3	VEL

Jaguar

FC-BWT66
BW-T65 / 66



MODELO						AÑOS	
Jaguar XJ6						76-87	
						MOTOR	
						L6	
TC	12	TRACC	T	OEM	3188896	3	VEL

FC-JF506E
JF506E



MODELO						AÑOS	
X Type						02-08	
						MOTOR	
						V6	
TC	20	TRACC	AWD	OEM	FP01-21-500	5	VEL

1.5 Filtro y empaque de transmisión automática

Automatic transmission filter kits



Jaguar

FC-ZF5HP30
ZF5HP30



MODELO					AÑOS		
Jaguar XJR					98-00		
					MOTOR		
					V8		
TC	23	TRACC	T	OEM	24341-422-419	5	VEL

Kia

FC-F4AEL
F4A-EL

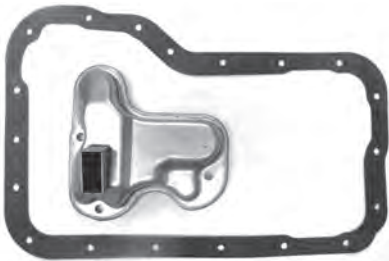

MODELO					AÑOS		
Rio, Spectra					00-09		
					MOTOR		
					L4		
TC	19	TRACC	D	OEM	KFW01-21-500	4	VEL

FC-F4A51T
F4A32 / F4A42
F4A51 / F5A51



MODELO					AÑOS		
Amanti, Magentis, Optima, Spectra, Sorento, Sportage					01-06		
					MOTOR		
					L4-V6		
TC	15	TRACC	T	OEM	46321-39010	4 y 5	VEL

Land Rover

FC-4HP22R
ZF4HP22
(Tubo de 5/8")



MODELO					AÑOS		
Land Rover, Range Rover					83-99		
					MOTOR		
					V8		
TC	N/R	TRACC	T	OEM	1043-226-037	4	VEL

1.5 Filtro y empaque de transmisión automática

Automatic transmission filter kits



Mazda

FC-6T70
6F50N / 6F55

MODELO						AÑOS	
Mazda 6						09-10	
						MOTOR	
						V6	
TC	N/R	TRACC	D	OEM	7T4Z-7A098-B	6	VEL

FC-E4N71B
E4N71B, N4A3L

MODELO						AÑOS	
Mazda 929, Miata, RX-7						88-97	
						MOTOR	
						L4, V6	
TC	14	TRACC	T	OEM	BV01-19-815	4	VEL

FC-F3AE
F3A / MX1

MODELO						AÑOS	
Mazda 323						88-89	
						MOTOR	
						L4	
TC	18	TRACC	D	OEM	FT21-19-815D	3	VEL

FC-F3AM
F3A / MX1

MODELO						AÑOS	
Mazda 323, 626, GLC						81-87	
						MOTOR	
						L4	
TC	18	TRACC	D	OEM	FT01-19-815	3	VEL

FC-FNR5
FNR5 / FS5A-EL

MODELO						AÑOS	
Mazda 3, Mazda 5, Mazda 6						05-11	
						MOTOR	
						L4	
TC	20	TRACC	D	OEM	FNC1-21-500	5	VEL

FC-G4AHL
G4A-HL
(1.250" ALTO)

MODELO						AÑOS	
Mazda 323						88-92	
						MOTOR	
						L4	
TC	17	TRACC	D	OEM	FU50-21-500A	4	VEL

1.5 Filtro y empaque de transmisión automática

Automatic transmission filter kits



Mazda

FC-GF4AEL
GF4AEL
(Filtro de 1" de alto)



MODELO						AÑOS	
Mazda 323, 626, Ford Probe						88-92	
						MOTOR	
						L4	
TC	17	TRACC	D	OEM	FU31-21-500	4	VEL

FC-JF403N
JF403E / L J4A-EL



MODELO						AÑOS	
Mazda Millenia						95-02	
						MOTOR	
						V6	
TC	22	TRACC	D	OEM	FX01-19-815	4	VEL

FC-JF506E
JF506E / JA5A-EL



MODELO						AÑOS	
Mazda 6S, MPV						02-06	
						MOTOR	
						V6	
TC	20	TRACC	D	OEM	FP01-21-500	5	VEL

FC-L4N71B
L4N71B (4WD)



MODELO						AÑOS	
Mazda B2600, MPV, RX7						86-89	
						MOTOR	
						L4	
TC	14	TRACC	T	OEM	BT40-19-815A	4	VEL

FC-R4AEL
R4A-EL

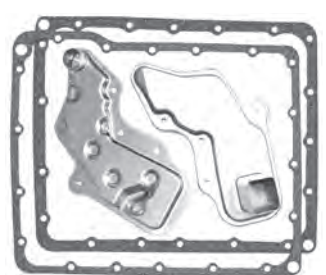

MODELO						AÑOS	
Mazda 929, MPV, RX7						89-99	
						MOTOR	
						Rotary, V6	
TC	20	TRACC	T	OEM	BV92-19-815	4	VEL

FC-TF81SC
AWTF81SC / AF21B



MODELO						AÑOS	
Mazda 6S, CX7, CX9						06-08	
						MOTOR	
						L4, V6	
TC		TRACC	D/AWD	OEM	60-27-0F099-0080	6	VEL

1.5 Filtro y empaque de transmisión automática

Automatic transmission filter kits



Mercedes Benz

FC-722
722.7



MODELO						AÑOS	
A140, A160, A180						97-04	
						MOTOR	
						L4	
TC	NR	TRACC	T	OEM	168-377-0395	5	VEL

FC-722.9
722.9



MODELO						AÑOS	
C230,C280,C300,C350,C63 AMG, CL500, CL550, CL63 AMG, CLK350,CLK500, CLK550						06-09	
						MOTOR	
						V6, V8	
TC	NR	TRACC	T	OEM	220-277-0395	7	VEL

FC-W3A040
722.1 / 722.2
(Filtro sin cuello)



MODELO						AÑOS	
220, 230, 240D, 280E, 300D, 300SEL, 450E, 450SEL, 450SLC						69-83	
						MOTOR	
						L4, L6, V8	
TC	NR	TRACC	T	OEM	115-270-03-98	3/4	VEL

FC-W3A040N
722.1 / 722.2
(con cuello de 3/4")



MODELO						AÑOS	
220, 230, 240D, 280E, 300D, 300SEL, 450E, 450SEL, 450SLC						72-80	
						MOTOR	
						L4, L6, V8	
TC	NR	TRACC	T	OEM	123-270-00-98	3/4	VEL

FC-W4A020
W4A020 (722.4)



MODELO						AÑOS	
Mercedes Benz 190D, 190E, C class						84-97	
						MOTOR	
						L4, L5, L6	
TC	NR	TRACC	T	OEM	126-277-02-95	4	VEL

FC-W4A040
W4A040 (722.3)



MODELO						AÑOS	
Mercedes Benz C class, E class						83-97	
						MOTOR	
						L5, L6, V8	
TC	NR	TRACC	T	OEM	126-277-02-95	4	VEL

1.5 Filtro y empaque de transmisión automática

Automatic transmission filter kits



Mercedes Benz

FC-W4B025
722.1 / 722.2
(con cuello de 1")



MODELO		AÑOS
220, 230, 240D, 280E, 300D, 300SEL, 450E, 450SEL, 450SLC		72-80
		MOTOR
		L4, L6, V8

TC	NR	TRACC	T	OEM	109-270-02-98	3/4	VEL
----	----	-------	---	-----	---------------	-----	-----

FC-W5A030
722.5



MODELO		AÑOS
300SL, S320, SL320		94-97
		MOTOR
		L6

TC	NR	TRACC	T	OEM	129-277-00-95	5	VEL
----	----	-------	---	-----	---------------	---	-----

FC-W5A580
W5A580/722.6



MODELO		AÑOS
Sprinter Van, C, CL, CLK Class, E Class, E Class Wagon, ML320, ML-430, S, SL		97-09
		MOTOR
		Todos

TC	NR	TRACC	T	OEM	140-277-0095	5	VEL
----	----	-------	---	-----	--------------	---	-----

Mitsubishi

FC-F1C1
F1C1



MODELO		AÑOS
Lancer, Colt		02-11
		MOTOR
		L4

TC	15	TRACC	D	OEM	MR515064	6	VEL
----	----	-------	---	-----	----------	---	-----

FC-F4A33
F4A32 / F4A33
W4A32 / W4A33



MODELO		AÑOS
Diamante, 3000 GT, Eclipse, Galant		91-00
		MOTOR
		L4, V6

TC	14	TRACC	D	OEM	MD735572 D	4	VEL
----	----	-------	---	-----	------------	---	-----

1.5 Filtro y empaque de transmisión automática

Automatic transmission filter kits



Mitsubishi

FC-F4A411CA
F4A41-1, F4A42-1



MODELO						AÑOS	
Diamante, Eclipse, Galant, Mirage						97-12	
						MOTOR	
						L4	
TC	NR	TRACC	D	OEM	MD752072	4 y 5	VEL

FC-F4A41A
F4A41 / F4A42



MODELO						AÑOS	
Mitsubishi Eclipse, Galant, Mirage						97-06	
						MOTOR	
						L4, V6	
TC	15	TRACC	D	OEM	MD758691	4	VEL

FC-F4A51A
F4A51



MODELO						AÑOS	
Mitsubishi Diamante						96-99	
						MOTOR	
						V6	
TC	15	TRACC	D	OEM	MD758684	4	VEL

FC-F4A51D
F4A51



MODELO						AÑOS	
Galant, Eclipse GS, GT, Endeavor						99-11	
						MOTOR	
						L4, V6	
TC	15	TRACC	D	OEM	MR350441	4	VEL

FC-F4A51T
F4A41 / 42



MODELO						AÑOS	
Montero Limited Outlander						01-04	
						MOTOR	
						L4-L6	
TC	15	TRACC	T	OEM	46321-39010	5	VEL

FC-KM171
*KM171, KM172,
KM-170-2*



MODELO						AÑOS	
Galant, Dodge Colt						82-87	
						MOTOR	
						L4, V6	
TC	12	TRACC	D	OEM	MD707786	4	VEL

1.5 Filtro y empaque de transmisión automática

Automatic transmission filter kits



Mitsubishi

FC-KM175
KM175,
KM176-5



MODELO						AÑOS	
Galant Dodge Colt						87-95	
						MOTOR	
						L4, V6	
TC	12/13	TRACC	D	OEM	MD673110	4	VEL

FC-KM176A
KM175 / KM176
KM177



MODELO						AÑOS	
Mitsubishi Cordia, Galant						84-91	
						MOTOR	
						L4, V6	
TC	12	TRACC	D	OEM	MD729955	4	VEL

FC-KM176N
KM175 / KM176
KM177



MODELO						AÑOS	
Mitsubishi Galant, Sigma, Sonata						87-93	
						MOTOR	
						L4, V6	
TC	13	TRACC	D	OEM	MD729955	4	VEL

FC-KM177
KM171 / KM177



MODELO						AÑOS	
Mitsubishi Eclipse, Expo LRV, Galant, Mirage, Sigma						87-92	
						MOTOR	
						L4	
TC	12	TRACC	D	OEM	MD729954	4	VEL

FC-R4A51
V4A51 / R4A51



MODELO						AÑOS	
Mitsubishi Montero, Montero Sport (sin cuello)						98-06	
						MOTOR	
						V6	
TC	20	TRACC	T	OEM	MR357710	4	VEL

FC-V4A51
V4A51



MODELO						AÑOS	
Montero Sport (con cuello)						98-06	
						MOTOR	
						V6	
TC	19	TRACC	4WD	OEM	MR528836	4	VEL

1.5 Filtro y empaque de transmisión automática

Automatic transmission filter kits



Nissan

FC-3N71A
JATCO 3N71B



MODELO					AÑOS		
Datsun 210, Pick Ups 620 - 720					72-86		
					MOTOR		
					L4		
TC	17	TRACC	T	OEM	31728-X0100	3	VEL

FC-4F02A
RL-4F02A
RE4F02A



MODELO					AÑOS		
Maxima, Pulsar NX, Stanza					85-94		
					MOTOR		
					V6		
TC	17	TRACC	D	OEM	31728-21X01	4	VEL

FC-4F04A
RE4F04A, 4F20E



MODELO					AÑOS		
Nissan Altima, Maxima, Quest / Mercury Villager					93-02		
					MOTOR		
					L4, V6		
TC	21	TRACC	D	OEM	31728-80X03	4	VEL

FC-4F04AN
4F04AN



MODELO					AÑOS		
Nissan Altima, Maxima, Quest					02-06		
					MOTOR		
					L4, V6		
TC	21	TRACC	D	OEM	31397-80X01	4	VEL

FC-4R01A2W



MODELO					AÑOS		
Pathfinder, Pick Ups (2WD)					90-99		
					MOTOR		
					V6		
TC	20	TRACC	T	OEM	31728-41X00	4	VEL

FC-4R01A4W
RE4R10A
RG4R01A
JR403E

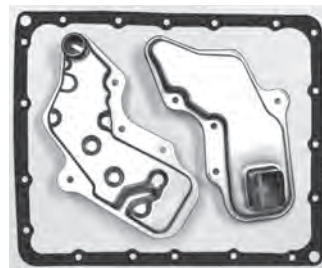

MODELO					AÑOS		
Pathfinder, Pick Ups, (4WD), Camionetas 2WD, 4WD					90-99		
					MOTOR		
					L4, V6		
TC	20	TRACC	T	OEM	31728-41X01	4	VEL

1.5 Filtro y empaque de transmisión automática

Automatic transmission filter kits



Nissan

FC-4R01AP
RL-4R01A



MODELO					AÑOS		
Frontier 2WD, 4WD, Frontier, Pick Ups (2WD)					90-97		
					MOTOR		
					L4, V6		
TC	20	TRACC	T	OEM	31728-48X00	4	VEL

FC-AW55
AW55-50SN



MODELO					AÑOS		
Nissan Altima, Maxima, Quest					04-08		
					MOTOR		
					V6		
TC	NR	TRACC	D	OEM	24220578	5	VEL

FC-DPO
DPO



MODELO					AÑOS		
Platina					02-10		
					MOTOR		
					L4		
TC	N/R	TRACC	D	OEM	7701-467-106	4	VEL

FC-JATCO
JATCO L-4N71B



MODELO					AÑOS		
Datsun 210, 510, Pick ups (2WD), Pathfinder					79-87		
					MOTOR		
					L4, V6		
TC	14	TRACC	T	OEM	31728-X8600	4	VEL

FC-JF010E
CVT RE0F09A



MODELO					AÑOS		
Nissan Murano					03-09		
					MOTOR		
					V6		
TC	21	TRACC	D/AWD	OEM	N / D	CVT	VEL

FC-JR503E
RE5R01A



MODELO					AÑOS		
Infinity Q45, Nissan 300ZX					90-01		
					MOTOR		
					V8		
TC	20	TRACC	T	OEM	31728-60X01	5	VEL

1.5 Filtro y empaque de transmisión automática

Automatic transmission filter kits



Nissan

FC-R4AEL
RE4R01A (4WD)



MODELO						AÑOS	
Xterra SE (4WD)						00-04	
						MOTOR	
						L4, V6	
TC	20	TRACC	T	OEM	31728-41X01	4	VEL

FC-RE0F10A
CVT RE0F10A



MODELO						AÑOS	
Nissan Altima (07-09), Maxima (07-09), Versa (07-10), Sentra (07-08), Rogue (07-08), trans. CVT RE0F10A						07-10	
						MOTOR	
						L4, V6	
TC	N / R	TRACC	D	OEM	31728-1XZ0A	CVT	VEL

FC-RE4F03V
RE4F03V



MODELO						AÑOS	
Nissan Tiida						08-12	
						MOTOR	
						L4	
TC	21	TRACC	D	OEM	31728-85X01	4	VEL

FC-RE4F04B
RE4F04A / B



MODELO						AÑOS	
Altima, Maxima, Quest						02-06	
						MOTOR	
						L4, V6	
TC	21	TRACC	D	OEM	31728-85X01	4	VEL

FC-RE4R03A
RE4R03A



MODELO						AÑOS	
240SX, 300ZX, Frontier, Xterra (2WD)						89-04	
						MOTOR	
						V8	
TC	20	TRACC	T	OEM	31728-51X02	4	VEL

FC-RE5R05A
RE5R05A



MODELO						AÑOS	
Nissan 350Z, Frontier, Armada, Titan, Pathfinder, Xterra XE						03-09	
						MOTOR	
						L4, V6, V8	
TC	24	TRACC	T	OEM	31728-97X00	5	VEL

1.5 Filtro y empaque de transmisión automática

Automatic transmission filter kits



Nissan

FC-RE7R01A
RE7R01A

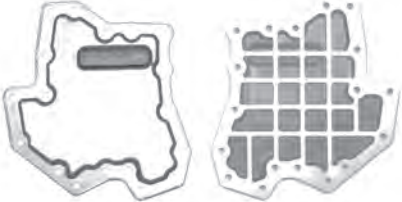

MODELO					AÑOS		
Nissan 370Z (09-14), Infiniti G35 (08-14), trans., 7 vel.					08-14		
					MOTOR		
					V6		
TC	N/R	TRACC	T	OEM	N/D	7	VEL

FC-RL3F01A
RL3F01A,
RN3F01A



MODELO					AÑOS		
Sentra, Pulsar (carter profundo)					87-92		
					MOTOR		
					L4		
TC	14	TRACC	D	OEM	31728-01X10	3	VEL

FC-RN3F01A
RN3F01A



MODELO					AÑOS		
Pulsar, Tsuru II, Sentra, Stanza					82-86		
					MOTOR		
					L4		
TC	14	TRACC	D	OEM	31728-01X08	3	VEL

FC-SENTRA
RL-4F03A



MODELO					AÑOS		
Tsuru III, Sentra, 200SX					94-06		
					MOTOR		
					L4		
TC	21	TRACC	D	OEM	31728-31X01	4	VEL

FC-TSURU
RN/RL 3F01A



MODELO					AÑOS		
Tsuru I, II, III y Sentra					84-94		
					MOTOR		
					L4		
TC	14	TRACC	D	OEM	31728-01X09	3	VEL

1.5 Filtro y empaque de transmisión automática Automatic transmission filter kits



Peugeot

FC-DPO
DPO / AL-4



MODELO					AÑOS	
206, 406, 407					99-07	
					MOTOR	
					L4	
TC	N/R	TRACC	D	OEM		VEL
				7701-467-106	4	VEL

FC-TF81SC
AWTF81SC / AF21B



MODELO					AÑOS	
Peugeot 307					06-08	
					MOTOR	
					L4, V6	
TC	N/R	TRACC	D	OEM		VEL
				60-27-0F099-0080	6	VEL

FC-ZF3HP22
ZF3HP22

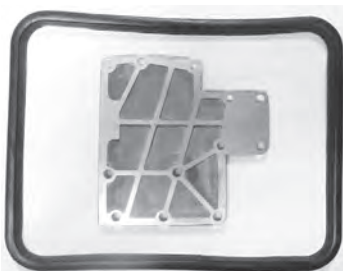

MODELO					AÑOS	
Peugeot					75-86	
					MOTOR	
					L4	
TC	N/R	TRACC	T	OEM		VEL
				24231-209-747	3	VEL

Renault

FC-DPO
DPO / AL-4



MODELO					AÑOS	
Clio, Scenic, Laguna					02-06	
					MOTOR	
					L4	
TC	N/R	TRACC	D	OEM		VEL
				7701-467-106	4	VEL

FC-M101
MB1 / MJ1 / MJ3



MODELO					AÑOS	
Alliance, Encore					84-86	
					MOTOR	
					L4	
TC	N/R	TRACC	D	OEM		VEL
				77-00-739-883	3	VEL

1.5 Filtro y empaque de transmisión automática

Automatic transmission filter kits



Renault

FC-MJ3

MB1 / MJ1 / MJ3



MODELO					AÑOS		
Alliance, Encore					82-85		
					MOTOR		
					L4		
TC	TRACC	D	OEM	T0727392	3	VEL	

Saab

FC-AW50

AW50-42LE



MODELO					AÑOS		
900, 900S, 9-2X, 9-3					94-07		
					MOTOR		
					L4		
TC	N/R	TRACC	D/AWD	OEM	30681088	4	VEL

FC-ZF4HP14

ZF4HP14



MODELO					AÑOS		
9000S (sin turbo)					94-98		
					MOTOR		
					L4		
TC	N/R	TRACC	D	OEM	1036-226-013	4	VEL

FC-ZF4HP18

ZF4HP18Q



MODELO					AÑOS		
9000, 9000S (con turbo)					94-98		
					MOTOR		
					L4		
TC	N/R	TRACC	D	OEM	7599525	4	VEL

1.5 Filtro y empaque de transmisión automática

Automatic transmission filter kits



Subaru

FC-4EATCA
4EAT / R4AXEL



MODELO						AÑOS	
Subaru Baja, Legacy, Forester, Outback						98-04	
						MOTOR	
						H4, H6	
TC		TRACC	D	OEM	38325-AA032	4	VEL

FC-4EATS
4EAT / R4AXEL



MODELO						AÑOS	
Subaru Baja, Legacy, Forester, Outback						98-04	
						MOTOR	
						H4, H6	
TC	20	TRACC	D	OEM	31728-AA050	4	VEL

FC-ECVT
ECVT



MODELO						AÑOS	
Subaru Justy						89-94	
						MOTOR	
						L3	
TC	13	TRACC	D	OEM	31728-KA031	CVT	VEL

FC-M41
M41



MODELO						AÑOS	
Subaru DL, GF						75-82	
						MOTOR	
						H4	
TC	13	TRACC	T	OEM	31728-X0F00	3	VEL

FC-M41A
M41A



MODELO						AÑOS	
DL, GF, GL, GL-10, RX, LOYALE, XT, XT6, BAJA						83-89	
						MOTOR	
						H4	
TC	14	TRACC	T	OEM	31728-X0100	3	VEL

FC-R4AXELA
R4AX-EL



MODELO						AÑOS	
Loyale, XT Coupe, XTGL, Station Wagon, Impreza						87-94	
						MOTOR	
						H4, H6	
TC	20	TRACC	T	OEM	31728-AA000	4	VEL

1.5 Filtro y empaque de transmisión automática

Automatic transmission filter kits



Subaru

FC-R4AXELN
R4AX-EL



MODELO						AÑOS	
Impresa, Legacy, SVX, Forester						93-99	
						MOTOR	
						H4, H6	
TC	20	TRACC	T	OEM	31728-AA011	4	VEL

Suzuki

FC-A43DE
A43DE , A44DE



MODELO						AÑOS	
Suzuki Vitara, Grand Vitara						99-04	
						MOTOR	
						Todos	
TC	14	TRACC	T	OEM	26582-57800	4	VEL

FC-AW50
AW50-42LE



MODELO						AÑOS	
Aerio						04-07	
						MOTOR	
						L4	
TC	N/R	TRACC	D/AWD	OEM	30681088	4	VEL

Toyota

FC-A141E
A141E



MODELO						AÑOS	
Camry						92-01	
						MOTOR	
						L4	
TC	15	TRACC	D	OEM	35330-32022	4	VEL

FC-A141L
**A141L, A140E,
A140L**

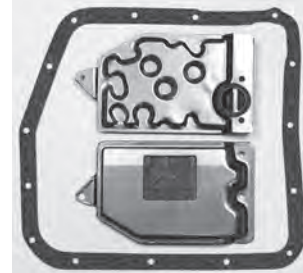

MODELO						AÑOS	
Camry, Corolla, Tercel						83-99	
						MOTOR	
						L4	
TC	15	TRACC	D	OEM	35330-20H00	4,3	VEL

1.5 Filtro y empaque de transmisión automática

Automatic transmission filter kits



Toyota

FC-A240E
A240E, A242L

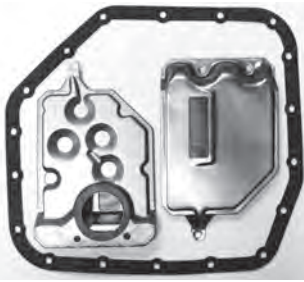

MODELO					AÑOS		
Camry ,Corolla, Tercel					83-88		
					MOTOR		
					L4		
TC	18	TRACC	D	OEM	35330-12011	4	VEL

FC-A245E
A245E

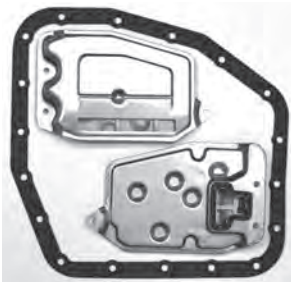

MODELO					AÑOS		
Corolla, RAV 4					93-03		
					MOTOR		
					L4		
TC	18	TRACC	D	OEM	35330-12040	4	VEL

FC-A246E
A246E

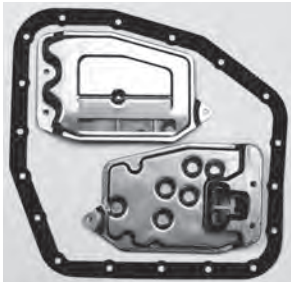

MODELO					AÑOS		
Corolla, Matrix					03-06		
					MOTOR		
					L4		
TC	18	TRACC	D	OEM	35330-12040	4	VEL

FC-A30
A30



MODELO					AÑOS		
Carina, Celica, Corolla, Corona, Crown, Mark II, Land Cruiser, Pick ups					70-78		
					MOTOR		
					L4, L6		
TC	16	TRACC	T	OEM	35303-30013	4	VEL

FC-A340
A340
(CUELLO DE 3/4" DE ALTO)



MODELO					AÑOS		
4 Runner, Landcruiser, Pick up T100, Tacoma					95-00		
					MOTOR		
					L4, V6		
TC	20	TRACC	T	OEM	35330-22010	4	VEL

FC-A340E
A340E



MODELO					AÑOS		
Pick Up, T100, Tacoma (2WD), 4Runner					85-99		
					MOTOR		
					V6		
TC	19	TRACC	T	OEM	35330-30011	4	VEL

1.5 Filtro y empaque de transmisión automática

Automatic transmission filter kits



Toyota

FC-A340F
A340F
(CUELLO DE 3/8" DE ALTO)

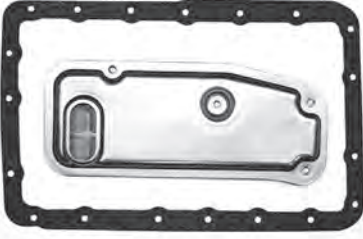

MODELO		AÑOS
T100, Tacoma (4WD)		95-97
		MOTOR
		4, 6

TC	19	TRACC	4WD	OEM	35330-60020	4	VEL
----	----	-------	-----	-----	-------------	---	-----

FC-A340F4
A340F



MODELO		AÑOS
4 Runner (4WD), Pick up		96-97
		MOTOR
		V6

TC	19	TRACC	T	OEM	35330-35020	4	VEL
----	----	-------	---	-----	-------------	---	-----

FC-A340H
A340H



MODELO		AÑOS
4 Runner, Pick up T100, Mitsubishi Montero		85-00
		MOTOR
		L4, V6

TC	19	TRACC	4WD	OEM	35303-35010	4	VEL
----	----	-------	-----	-----	-------------	---	-----

FC-A341E
A341E

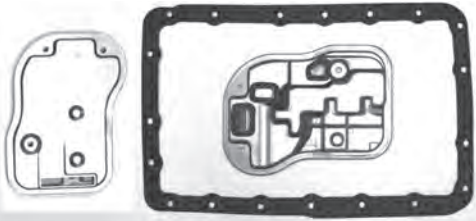

MODELO		AÑOS
4Runner, Tundra (2WD)		00-03
		MOTOR
		L6, V8

TC	19	TRACC	T	OEM	35330-30020	4	VEL
----	----	-------	---	-----	-------------	---	-----

FC-A343F
A343F



MODELO		AÑOS
4Runner, Landcruiser, Sequoia, Tacoma, Tundra		98-12
		MOTOR
		V6, V8

TC	19	TRACC	T	OEM	35330-60030	4	VEL
----	----	-------	---	-----	-------------	---	-----

FC-A350E
A350E

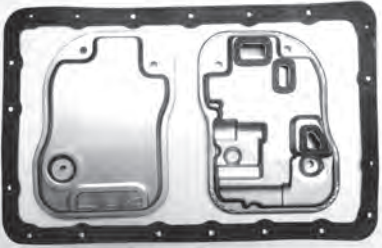

MODELO		AÑOS
Lexus GS300		94-95
		MOTOR
		L4, V6

TC	19	TRACC	T	OEM	35330-30040	4	VEL
----	----	-------	---	-----	-------------	---	-----

1.5 Filtro y empaque de transmisión automática Automatic transmission filter kits



Toyota

FC-A40D
A40D, A41D

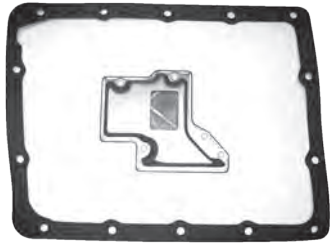

MODELO		AÑOS					
Celica, Corona, Corolla, Supra		77-85					
		MOTOR					
		L4					
TC	14	TRACC	T	OEM	35303-30031	3	VEL

FC-A41
A41, A40

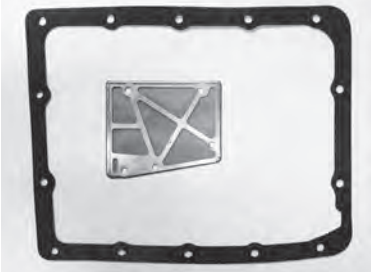

MODELO		AÑOS					
Celica, Corolla, Corona, Pick up Hilux		73-81					
		MOTOR					
		L4					
TC	14	TRACC	T	OEM	35303-22020	3	VEL

FC-A42DL
A42DL

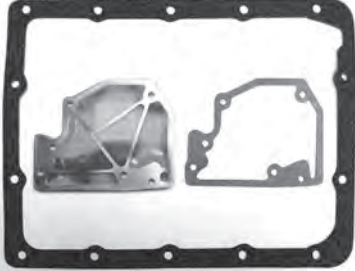

MODELO		AÑOS					
Corolla, 4Runner, Land Cruiser, Pick ups		82-87					
		MOTOR					
		L4, L6					
TC	14	TRACC	T	OEM	35303-14010	4	VEL

FC-A43D
A43D



MODELO		AÑOS					
4Runner, Pick ups, Tacoma		84-01					
		MOTOR					
		L4					
TC	14	TRACC	T	OEM	35303-30050	4	VEL

FC-A43DE
A43DE



MODELO		AÑOS					
4Runner, Pick ups, Previa		81-97					
		MOTOR					
		L4, L6					
TC	14	TRACC	T	OEM	35303-33060	4	VEL

FC-A440F
A440F
(5/8" de alto)

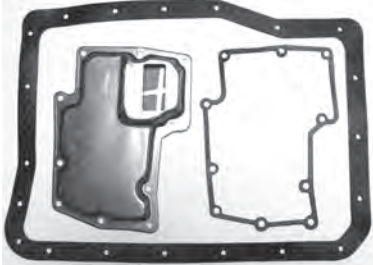

MODELO		AÑOS					
Landcruiser (2WD)		85-92					
		MOTOR					
		L4, L6					
TC	20	TRACC	T	OEM	35330-60011	4	VEL

1.5 Filtro y empaque de transmisión automática

Automatic transmission filter kits



Toyota

FC-A440FD
A440F
(PROFUNDO)



MODELO						AÑOS	
Toyota Land Cruiser (4WD)						85-92	
						MOTOR	
						L4, L6	
TC	20	TRACC	T	OEM	35303-60011	4	VEL

FC-A46DE
A43DE / A46DE



MODELO						AÑOS	
Tacoma						02-04	
						MOTOR	
						L4	
TC	14	TRACC	T	OEM	35303-35020	4	VEL

FC-A540E
A540E, A540H

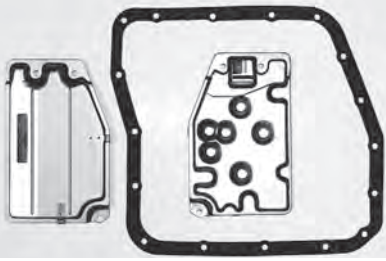

MODELO						AÑOS	
Camry, RAV 4, Sienna						88-00	
						MOTOR	
						L4, V6	
TC	17	TRACC	D	OEM	35330-32031	4	VEL

FC-A541E
A541E

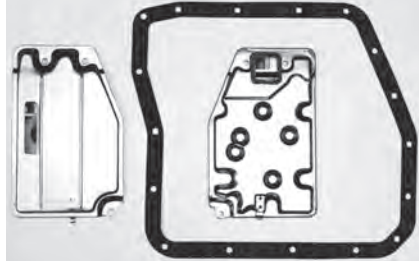

MODELO						AÑOS	
Camry, Sienna, Solara						94-06	
						MOTOR	
						V6	
TC	17	TRACC	D	OEM	35330-33030	4	VEL

FC-A55F
A55F



MODELO						AÑOS	
Tercel (2WD)						79-88	
						MOTOR	
						L4	
TC	17	TRACC	D	OEM	35303-16020	3	VEL

FC-A55F4
A55F



MODELO						AÑOS	
Tercel (4WD)						84-87	
						MOTOR	
						L4	
TC	17	TRACC	D	OEM	35303-16030	3	VEL

1.5 Filtro y empaque de transmisión automática

Automatic transmission filter kits



Toyota

FC-A650E
A650E

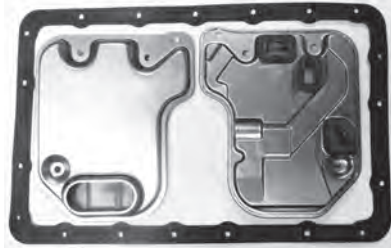

MODELO					AÑOS		
Lexus ES300, GS300, GS430, IS300, SC430					98-05		
					MOTOR		
					L6, V8		
TC	18	TRACC	T	OEM	35330-30070	5	VEL

FC-A750E
A750E / A750F



MODELO					AÑOS		
Toyota 4Runner, Land Cruiser, Tacoma, Tundra , FJ Cruiser, Sequoia (2WD)					03-09		
					MOTOR		
					V6, V8		
TC	20	TRACC	T	OEM	35330-60050	5	VEL

FC-A750F
A442F



MODELO					AÑOS		
4Runner, FJ Cruiser, Sequoia, Tacoma, Tundra (4WD)					03-09		
					MOTOR		
					L6		
TC	20	TRACC	T	OEM	35330-60010	4	VEL

FC-U140E
U140E/F
U240E

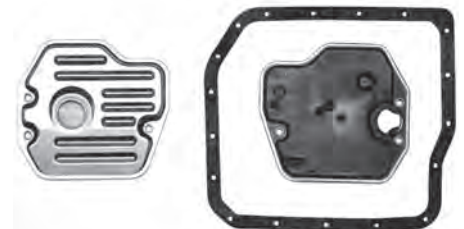

MODELO					AÑOS		
Camry, Celica, Matrix, RAV-4, Highlander					00-10		
					MOTOR		
					L4, V6		
TC	18	TRACC	D, T	OEM	35330-0W010	4	VEL

FC-U151E
U150E
U151E
U250E

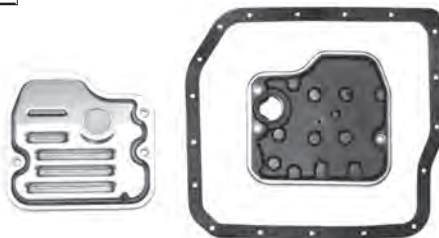

MODELO					AÑOS		
Avalon, Corolla, Matrix, RAV-4, Sienna, Highlander, Camry					04-13		
					MOTOR		
					V6		
TC	18	TRACC	D	OEM	35330-08010	5	VEL

FC-U341E
U341E

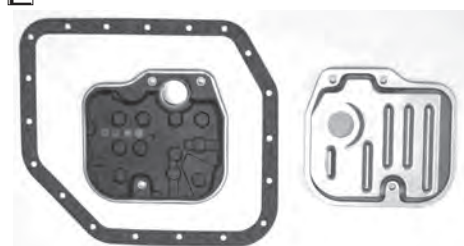

MODELO					AÑOS		
Corolla, Matrix, Yaris					03-12		
					MOTOR		
					L4		
TC	19	TRACC	AWD	OEM	35330-20020	4	VEL

1.5 Filtro y empaque de transmisión automática

Automatic transmission filter kits



Toyota

FC-U540E
U540E



MODELO					AÑOS		
Toyota Yaris sedan (USA)					07-13		
					MOTOR		
					L4		
TC	N / R	TRACC	D	OEM	35303-67206	4	VEL

FC-U660E
U660E

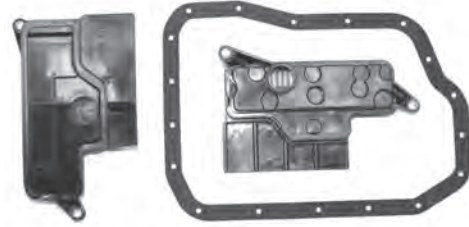

MODELO					AÑOS		
Toyota Camry, RAV4, Sienna, Matrix, Highlander, Corolla					03-13		
					MOTOR		
					V6		
TC	18	TRACC	D	OEM	35330-33050	6	VEL

Transmisión Allison

FC-AT540
AT540-543-545



MODELO					AÑOS		
Series AT540, AT543, AT545					72-00		
					MOTOR		
					--		
TC	21	TRACC	T	OEM	6837428	4	VEL

FC-HT700
SERIE HT700

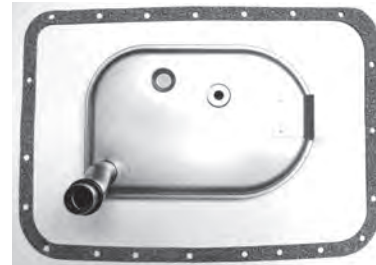

MODELO					AÑOS		
Uso universal, serie HT-700 (tubo de 5" de alto)					72-00		
					MOTOR		
					--		
TC	21	TRACC	T	OEM	29538491	4	VEL

FC-HT740
SERIE HT740



MODELO					AÑOS		
Uso universal, serie HT740 (tubo de 6" de alto)					72-00		
					MOTOR		
					--		
TC	21	TRACC	T	OEM	6839945	4	VEL

FC-HT750
SERIE HT750

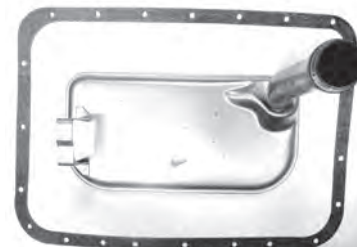

MODELO					AÑOS		
Uso Universal, serie HT750 (tubo de 7" de alto)					72-00		
					MOTOR		
					--		
TC	21	TRACC	T	OEM	23013625	4	VEL

1.5 Filtro y empaque de transmisión automática Automatic transmission filter kits



Transmisión Allison

FC-L1000
1000/2000/2400



MODELO					AÑOS		
GM Silverado C2500, C3500, GMC Sierra 2500, 3500 (carter bajo)					01-12		
					MOTOR		
					V8		
TC	12	TRACC	T	OEM	29537965	5	VEL

FC-L1000A
1000/2000/2400



MODELO					AÑOS		
GM Silverado C2500, C3500, GMC Sierra 2500, 3500 (carter profundo)					01-12		
					MOTOR		
					V8		
TC	12	TRACC	T	OEM	29537966	5	VEL

FC-L1000CA
1000/2000/2400



MODELO					AÑOS		
GM Silverado C2500, C3500, GMC Sierra 2500, 3500 (filtro secundario)					01-12		
					MOTOR		
					V8		
TC	NR	TRACC	T	OEM	29539579	5	VEL

FC-MT640
MT640-650

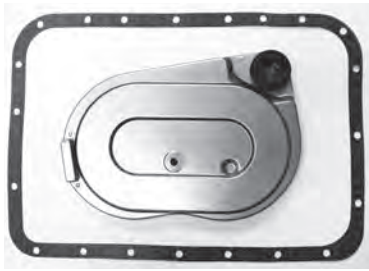

MODELO					AÑOS		
Series MT640, MT650					72-00		
					MOTOR		
					--		
TC	21	TRACC	T	OEM	6834831	4	VEL

Universales

FC-F38CA
(entrada de 3/8")



MODELO					AÑOS		
Filtro magnetico para enfriador de aceite					Todos		
					MOTOR		
					L4, V6, V8		
TC	N/R	TRACC	D/T	OEM	N / D	todas	VEL

FC-F516CA
(entrada de 5/16")



MODELO					AÑOS		
Filtro magnetico para enfriador de aceite					Todos		
					MOTOR		
					L4, V6, V8		
TC	N/R	TRACC	D/T	OEM	N / D	Todas	VEL

1.5 Filtro y empaque de transmisión automática

Automatic transmission filter kits



Volkswagen

FC-4HP18FLA
ZF4HP18FLA

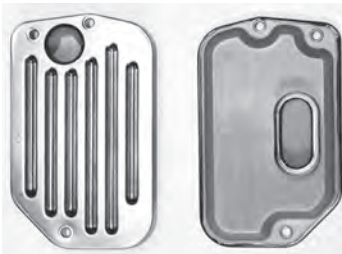

MODELO		AÑOS
Audi 100 Quattro, A6 Quattro, A8 Quattro, Porsche 911		92-97
		MOTOR
		V6

TC	N/R	TRACC	AWD	OEM	01F-325-433	4	VEL
----	-----	-------	-----	-----	-------------	---	-----

FC-5HP19
ZF5HP19/FLA



MODELO		AÑOS
Passat, Audi A4, A6		96-04
		MOTOR
		Todos

TC	27	TRACC	D	OEM	01V-325-429	5	VEL
----	----	-------	---	-----	-------------	---	-----

FC-VW003
VW003



MODELO		AÑOS
Dasher, Karmann Ghia, Thing, Transporter, Audi 100 Series, Audi Fox		69-76
		MOTOR
		H4, L4

TC	13	TRACC	T	OEM	003 325 421	3	VEL
----	----	-------	---	-----	-------------	---	-----

FC-VW010
VW 010



MODELO		AÑOS
Caribe, Atlantic, Golf A2, Jetta A2		77-92
		MOTOR
		L4

TC	NR	TRACC	D	OEM	010-325-421A	3	VEL
----	----	-------	---	-----	--------------	---	-----

FC-VW010A
VW 010



MODELO		AÑOS
Caribe, Rabbit (USA)		75-76
		MOTOR
		L4

TC	NR	TRACC	D	OEM	010-325-421	3	VEL
----	----	-------	---	-----	-------------	---	-----

FC-VW010E
VW 097



MODELO		AÑOS
Eurovan		91-95
		MOTOR
		L4

TC	5	TRACC	D	OEM	095 325 429C/D	4	VEL
----	---	-------	---	-----	----------------	---	-----

1.5 Filtro y empaque de transmisión automática

Automatic transmission filter kits



Volkswagen

FC-VW01J
01J MULTITRONIC



MODELO		AÑOS
A4 , Cabriolet, A6		02-09
		MOTOR
		L4, V6

TC	N / R	TRACC	D	OEM	01J 301 519L	CVT	VEL
----	-------	-------	---	-----	--------------	-----	-----

FC-VW02E
VW02E



MODELO		AÑOS
Audi TT, VW Rabbit		02-04
		MOTOR
		L5, V6

TC	N / R	TRACC	D	OEM	02E-325-429	6	VEL
----	-------	-------	---	-----	-------------	---	-----

FC-VW02EN
VW02EN



MODELO		AÑOS
VW Rabbit , Golf R32 , Golf GTI,Eos,Audi A3, Audi TT		05-08
		MOTOR
		L5, V6

TC	N / R	TRACC	D	OEM	02E-325-429D	6	VEL
----	-------	-------	---	-----	--------------	---	-----

FC-VW095
VW 095 / 096



MODELO		AÑOS
Golf A3 ,Jetta A3, Passat		90-96
		MOTOR
		L4

TC	4	TRACC	D	OEM	095-325-429C	4	VEL
----	---	-------	---	-----	--------------	---	-----

FC-VW098
VW 098



MODELO		AÑOS
Eurovan		96-03
		MOTOR
		Todos

TC	5	TRACC	D	OEM	01P-325-429	4	VEL
----	---	-------	---	-----	-------------	---	-----

FC-VW09D
09D (TR-60SN)

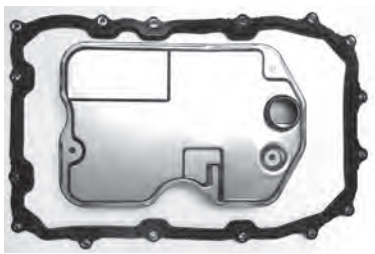

MODELO		AÑOS
VW Touareg, Audi Q7		04-09
		MOTOR
		V6, V8, V10

TC	16	TRACC	T/AWD	OEM	09D-325-429	6	VEL
----	----	-------	-------	-----	-------------	---	-----

1.5 Filtro y empaque de transmisión automática

Automatic transmission filter kits



Volkswagen

FC-VW09E
VW09E



MODELO						AÑOS	
Audi A8, Audi S6, Audi S8						04-08	
						MOTOR	
						V6, V8	
TC	13	TRACC	AWD	OEM	09E-325-429	6	VEL

FC-VW09G
AWTF60SN

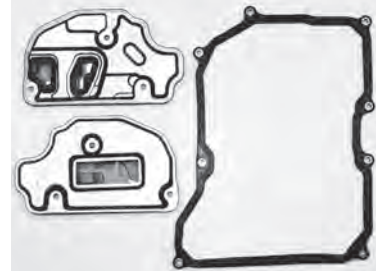

MODELO						AÑOS	
Beetle, Eos, Golf, Jetta, Passat, Rabbit, Bora						04-07	
						MOTOR	
						L4, L5, V6	
TC	8	TRACC	D	OEM	09G 325 429	6	VEL

FC-VW09M
VW09M

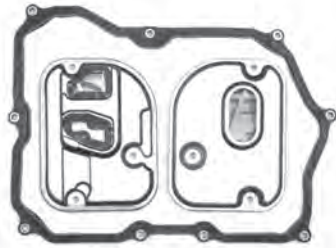

MODELO						AÑOS	
VW Passat 3.6L, VW Passat Wagon 3.6L						06-08	
						MOTOR	
						V6	
TC	9	TRACC	D	OEM	09M-325-429	6	VEL

FC-VWAG4
AG4



MODELO						AÑOS	
Beetle, Golf, Jetta						96-05	
						MOTOR	
						L4	
TC	4	TRACC	D	OEM	01M-325-429	4	VEL

FC-ZF6HP19A
ZF6HP19A

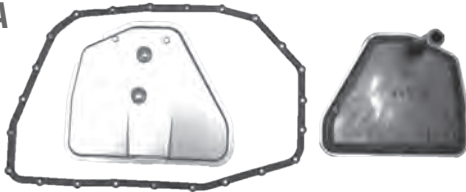

MODELO						AÑOS	
Audi A4 (05-08), A6, Audi S4 / RS4, VW Phaeton						04-08	
						MOTOR	
						V6, V8	
TC	23	TRACC	AWD	OEM	09L-325-429	6	VEL

FC-ZF8HP45
ZF8HP45



MODELO						AÑOS	
Audi Q7 3.6L						07-10	
						MOTOR	
						V6	
TC	13	TRACC	AWD	OEM	0AT-325-429	6	VEL

1.5 Filtro y empaque de transmisión automática Automatic transmission filter kits



Volvo

FC-AW50
AW50-42LE



MODELO					AÑOS		
C70, S40, S70, S80, V70					98-04		
					MOTOR		
					L4, L5		
TC	N/R	TRACC	D/AWD	OEM	30681088	4	VEL

MAX

performance

By 

CABLES PARA BUJIAS

de alta calidad para todas las marcas de vehículos.



MAX[®]

performance



Resuelve cualquier duda de aplicaciones o soporte técnico

01-800-227-5634 (CAS-LODI)

SOPORTE TÉCNICO GRATUITO



@IALodi



: Refacciones
Automotrices Lodi

Sé parte del mejor equipo
¡Nuevo Catálogo!

Solicítalo a tus distribuidores









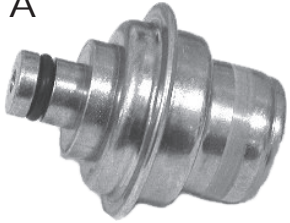

www.lodi.com.mx

1.6 Moduladores Modulators



Ford

<p>MO-A4LD</p> 	<p>MO-C3</p> 	<p>MO-C4 A AMARILLO</p> 
<p>Camionetas 4 y V6, 4 vel, desde 89</p>	<p>Fairmont, Cougar, V6, V8 3 vel, desde 81</p>	<p>Autos y Camionetas V6, V8 3 vel, 69-81</p>
<p>MO-C4 R BLANCO CON ROSA</p> 	<p>MO-C4/C5 VERDE</p> 	<p>MO-C6 PÚRPURA</p> 
<p>Autos y Camionetas V6, V8 3 vel. 69-81</p>	<p>Autos y Camionetas V6, V8 3 vel. 69-81</p>	<p>Autos y Camionetas V8, 3 vel.</p>
<p>MO-C6 V VERDE</p> 	<p>MO-FMX VERDE CON ROSCA</p> 	<p>MO-FMX A AZUL CON ROSCA</p> 
<p>Autos y Camionetas V8, 3 vel.</p>	<p>Autos y Camionetas V8, 3 vel. 68-77</p>	<p>Autos y Camionetas V8, 3 vel. 68-77</p>

General Motors

<p>MO-TH350/400 CAFÉ</p> 	<p>MO-TH440</p> 	<p>MO-TH180</p> 
<p>TH250 y TH350 V6 y V8 3 vel. TH400 67-89</p>	<p>TH440T4/AT60 V6 y V8 4 vel. desde 89</p>	<p>TH180 GM Autos L4, 3 vel., 69-97</p>

1.6 Moduladores Modulators



Nissan

MO-JATCO
CON ROSCA



Nissan-Datsun, 4 cil.
3 vel. 71-87

Transmisión Allison

MO-AT540



Transmisiones Allison AT540, AT543,
AT545, 4 vel, 70 en adelante



LAS MÁS AMPLIA GAMA DE PRODUCTOS

- Filtro y empaque de transmisión automática
- Aros dentados
- Juegos de sellos para monoblock
- Guías de válvula
- Soportes de barra cardán
- Poleas de cigüeñal
- Tapas de distribución
- Horquillas de Clutch
- Partes para sistema de freno
- Partes para dirección
- Miscelánea

¿ALGUNA DUDA?
Comunicate con los expertos
01 800 227 5634

***Se un líder,
Se parte del mejor equipo***

1.7 Volantes estándar Flywheels



Ford

WOH-7001

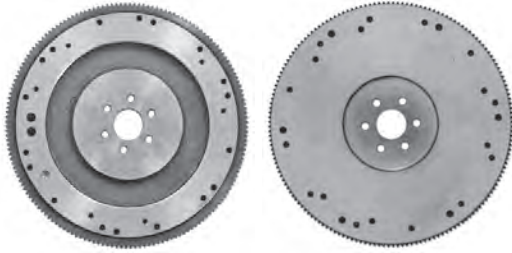

OEM	EOTZ-6375-A	No. Dientes	164	Diám. Ext.	14.25"
-----	-------------	-------------	-----	------------	--------

Pick ups F-100, F-150
L6 300 (4.9L) (80-96)

WOH-7002

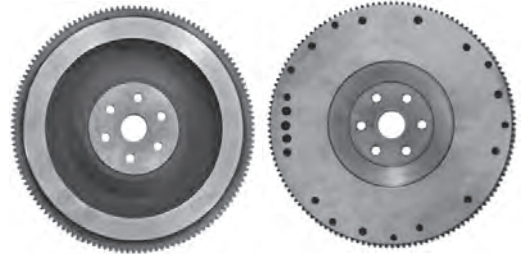

OEM	F0ZZ-6375-A	No. Dientes	132	Diám. Ext.	11.25"
-----	-------------	-------------	-----	------------	--------

Ford Ranger, Mazda B2300
L4 140 (2.3L) (83-96)

WOH-7003

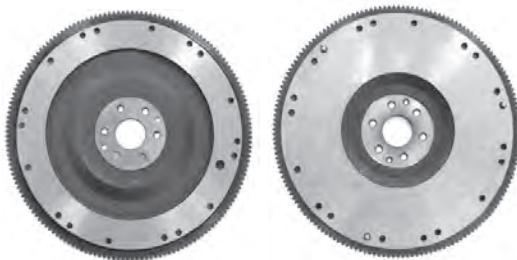

OEM	F6TZ-6375-AA	No. Dientes	164	Diám. Ext.	14.25"
-----	--------------	-------------	-----	------------	--------

Pick ups F-150
V6 4.2L (97-08)

WOH-7004

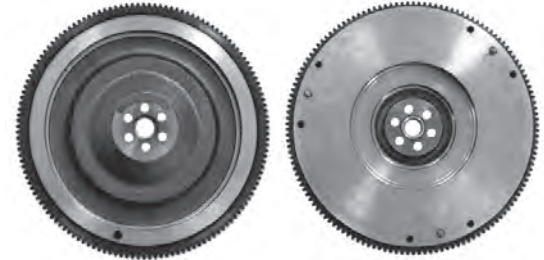

OEM	E5TZ-6375-E	No. Dientes	138	Diám. Ext.	11.46"
-----	-------------	-------------	-----	------------	--------

Ford Ranger V6 171 (2.8L) (1985),
177 (2.9L) (86-92)

WOH-7005

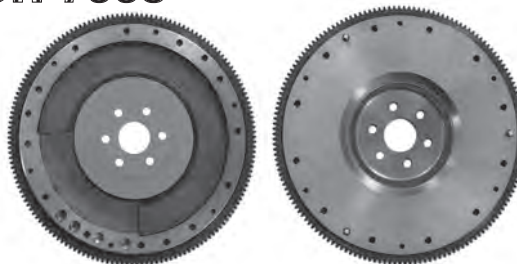

OEM	E6ZZ-6375-A	No. Dientes	157	Diám. Ext.	13.25"
-----	-------------	-------------	-----	------------	--------

Mustang V8 302 (5.0L) (86-95)

WOH-7007

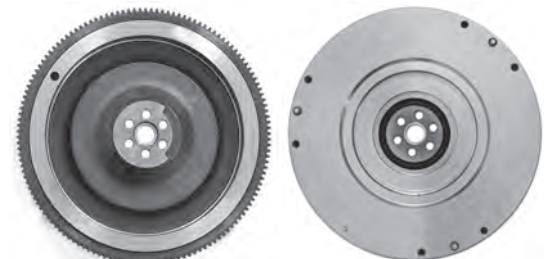

OEM	F0TZ-6375-A	No. Dientes	138	Diám. Ext.	11.46"
-----	-------------	-------------	-----	------------	--------

Ford Ranger, Mazda B4000
V6 4.0L (244) (90-97)

1.7 Volantes estándar Flywheels



Ford

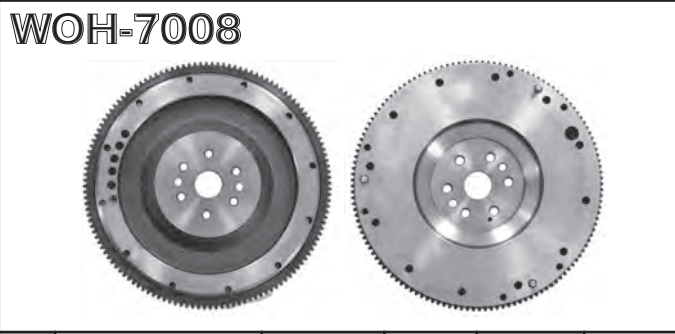

OEM	E69Z-6375-B	No. Dientes	132	Diám. Ext.	11.25"
-----	-------------	-------------	-----	------------	--------

Ford Ranger, Mazda B3000
V6 183 (3.0L) (86-94)

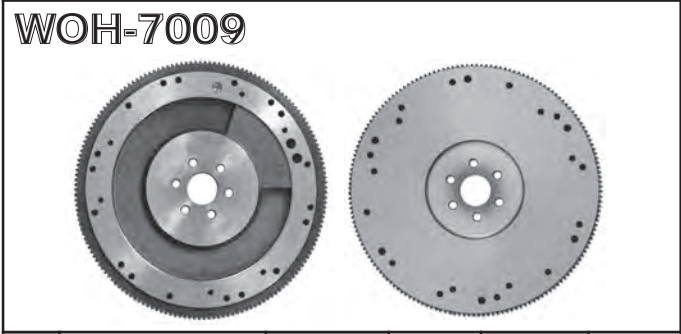

OEM	E8TZ-6375-D	No. Dientes	164	Diám. Ext.	14.25"
-----	-------------	-------------	-----	------------	--------

Pick ups F-100, F-150 V6 232 (3.8L),
V8 302 (5.0L), 351 (5.8L) (81-96)

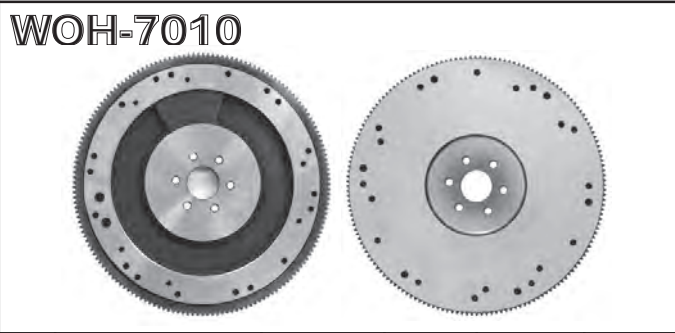

OEM	E8TZ-6375-C	No. Dientes	164	Diám. Ext.	14.25"
-----	-------------	-------------	-----	------------	--------

Pick ups F-100, F-150
V6 232, V8 302, 351 (67-87)

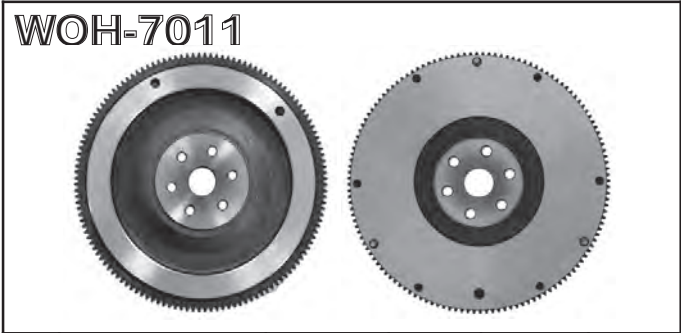

OEM	F57Z-6375-A	No. Dientes	132	Diám. Ext.	11.25"
-----	-------------	-------------	-----	------------	--------

Ford Ranger, Mazda B2300, B2500
2.3L, 2.5L (95-01)

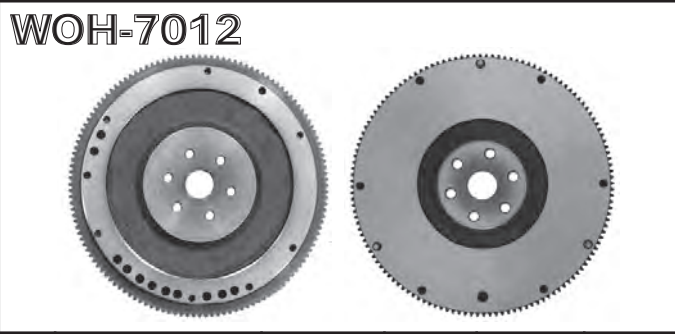

OEM	F0CZ-6375-A	No. Dientes	132	Diám. Ext.	11.25"
-----	-------------	-------------	-----	------------	--------

Ford Escort, Mercury Tracer
1.9L (91-96)

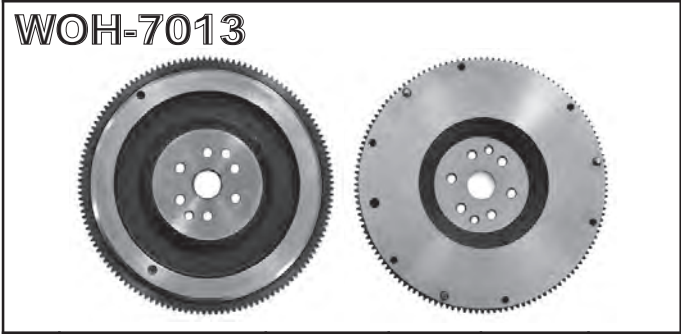

OEM	F57Z-6375-B	No. Dientes	132	Diám. Ext.	11.25"
-----	-------------	-------------	-----	------------	--------

Ford Ranger, Mazda B3000
V6 3.0L (95-05)

1.7 Volantes estándar Flywheels



General Motors

WOH-1000

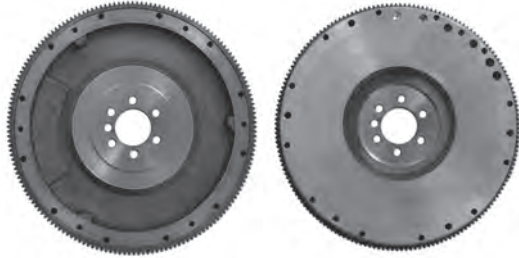

OEM	10105832	No. Dientes	168	Diám. Ext.	14.25"
-----	----------	-------------	-----	------------	--------

Chevrolet, GMC Pick ups V6 262 (4.3L),
V8 305 (5.0L), 350 (5.7L) (86-96)

WOH-1002

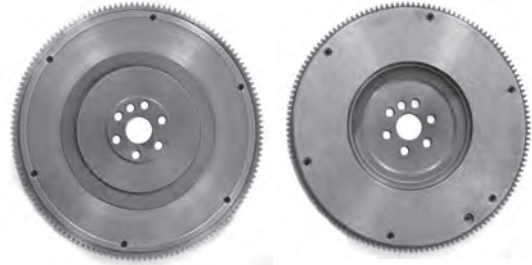

OEM	10118669	No. Dientes	142	Diám. Ext.	11.87"
-----	----------	-------------	-----	------------	--------

Chevrolet, GMC, Isuzu (autos y pick ups) L4 121 (2.0L),
134 (2.2L), V6 173 (2.8L), 189 (3.1L) (82-96)

WOH-1003

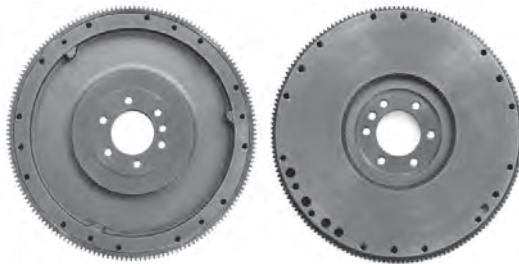

OEM	3991469	No. Dientes	168	Diám. Ext.	14.12"
-----	---------	-------------	-----	------------	--------

Chevrolet, GMC, Pontiac (autos y pick ups)
L6 250, V8 283, 307, 327, 350, 400, 402, 427 (67-85)

WOH-1004



OEM	14085720	No. Dientes	153	Diám. Ext.	12.75"
-----	----------	-------------	-----	------------	--------

Chevrolet Camaro, Corvette, Pontiac Firebird
V8 305, 350, 427 (66-85)

WOH-1005

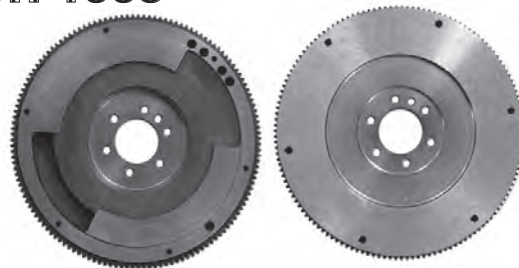

OEM	LFW126, 12556799	No. Dientes	139	Diám. Ext.	14"
-----	------------------	-------------	-----	------------	-----

Chevrolet, GMC Pick ups
V8 6.5L (diesel) (92-00)

WOH-1006

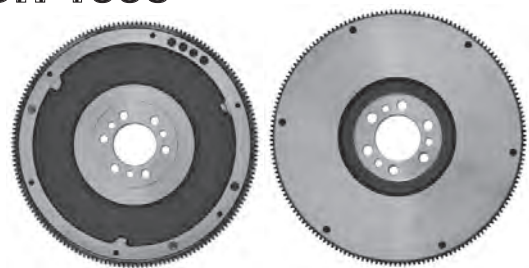

OEM	93414855	No. Dientes	168	Diám. Ext.	14.12"
-----	----------	-------------	-----	------------	--------

Chevrolet, GMC Pick ups
L6 292 (67-89)

1.7 Volantes estándar Flywheels



General Motors

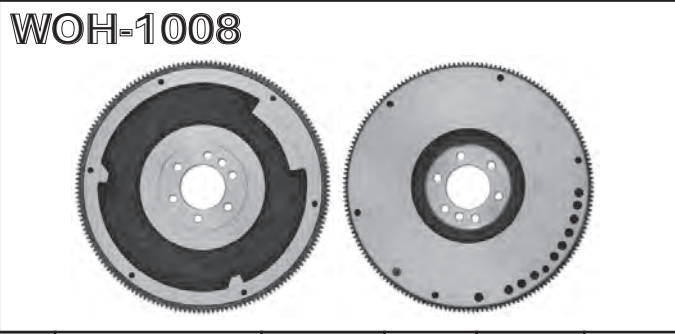

OEM	3993827	No. Dientes	168	Diám. Ext.	14.12"
------------	---------	--------------------	-----	-------------------	--------

Chevrolet, GMC Pick ups
V8 454 (7.4L) (73-90)

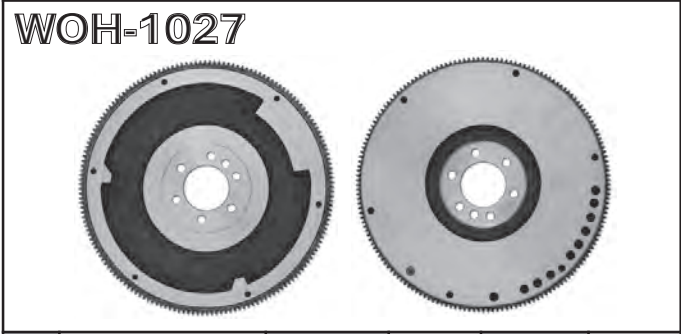

OEM	10101169	No. Dientes	168	Diám. Ext.	14"
------------	----------	--------------------	-----	-------------------	-----

Chevrolet, GMC Pick ups
V8 7.4L (91-95)

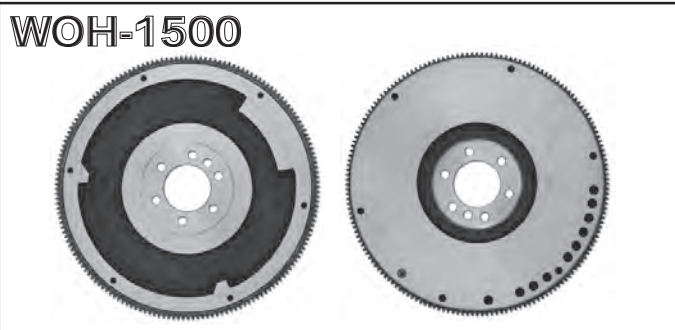

OEM	3986394	No. Dientes	168	Diám. Ext.	14"
------------	---------	--------------------	-----	-------------------	-----

Chevrolet, GMC Pick ups
V8 454 (70-80)

Jeep

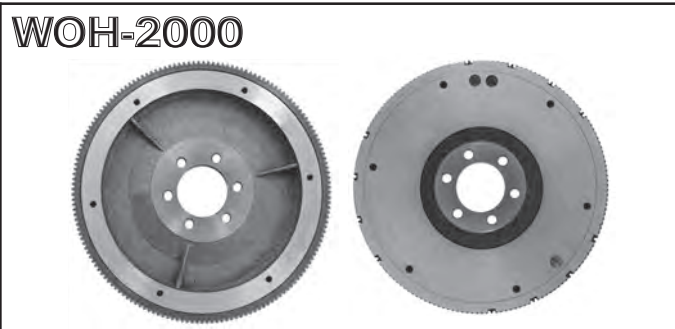

OEM	53005524	No. Dientes	164	Diám. Ext.	13.83"
------------	----------	--------------------	-----	-------------------	--------

Jeep Cherokee, Grand Cherokee, Comanche,
Wrangler L6 4.0L (91-05)

1.7 Volantes estándar Flywheels



Mercedes Benz

WOH-8001



OEM	N / D	No. Dientes	133	Diám. Ext.	15.88"
-----	-------	-------------	-----	------------	--------

Mercedes Benz L1621/54, 1621/59,
L1621/60 (hidraulico), motor OM366 (86-97)

WOH-8002



OEM	N / D	No. Dientes	133	Diám. Ext.	15.88"
-----	-------	-------------	-----	------------	--------

Mercedes Benz L1621/54, 1621/59,
L1621/60 (mecánico), motor OM366 (86-97)

Navistar

WOH-9001



OEM	N / D	No. Dientes	138	Diám. Ext.	17.42"
-----	-------	-------------	-----	------------	--------

Navistar DT360/466
(8 barrenos)

WOH-9002



OEM	N / D	No. Dientes	138	Diám. Ext.	17.42"
-----	-------	-------------	-----	------------	--------

Navistar DT466E
(12 barrenos)

Nissan

WOH-3000



OEM	1231085G06	No. Dientes	120	Diám. Ext.	12.50"
-----	------------	-------------	-----	------------	--------

Nissan Pick ups L4 1952cc, 2187cc, 2389cc
(motores Z20, Z22, Z24), 2.4L (KA24E) (83-97)

Subaru

WOH-4000

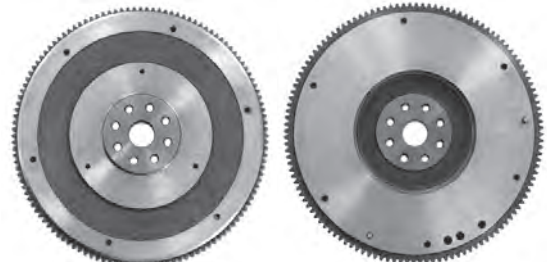





OEM	12310AA090	No. Dientes	124	Diám. Ext.	12.42"
-----	------------	-------------	-----	------------	--------

Impreza, Legacy
H4 1.8L, 2.2L (90-01)







2.1 Horquilla de clutch Clutch fork

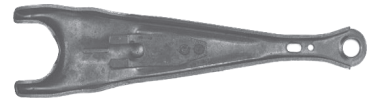

American motors

<p>HC-AMC</p>  <p>5361620</p> <p>Cherokee, Jeep CJ5 y CJ7 Wagoneer, J10/20 (80-87)</p>	<p>HC-AMC C/P</p>  <p>3224192</p> <p>Rambler, Gremlin, Pacer (64-87) Jeep Wagoneer, Cherokee (76-80) (con pernos para portacollarin)</p>	<p>HC-AMC 13</p>  <p>1378486</p> <p>Jeep CJ5 (1965-1973)</p>
<p>HC-AMC 11</p>  <p>3217480</p> <p>Jeep Wagoneer, J10, J20 (74-79)</p>		

Chrysler / Dodge

<p>HC-D ATOS</p>  <p>41430-02010</p> <p>Dodge Atos L4 1.0L (01-adelante)</p>	<p>HC-D 100</p>  <p>3643998</p> <p>Camionetas Dodge serie D 100 y D 300, hasta modelo 1979</p>	<p>HC-D 150</p>  <p>4210697</p> <p>Camionetas Dodge serie D 150 y D 350 modelos 1980 en adelante</p>
<p>HC-D 150 H6</p>  <p>04340215</p> <p>Camioneta Dodge 6 cil. Modelos 1988 en adelante clutch hidraulico</p>	<p>HC-D 150 HV6</p>  <p>52107555</p> <p>Camioneta Dodge serie D150 motor V6 modelos 1992 en adelante (clutch hidraulico)</p>	<p>HC-D 150 H8</p>  <p>04446231</p> <p>Camioneta Dodge 8 cil. Modelos 1988 en adelante (clutch hidráulico)</p>

2.1 Horquilla de clutch Clutch fork







Chrysler / Dodge

<p>SHC-D 150 H8</p>  <p>04338855</p>	<p>HC-D 600</p>  <p>3640749</p>	<p>HC-D 600 H</p>  <p>4559956</p>
<p>Seguro para HC-D 150 H8</p>	<p>Camión Dodge serie D 600 Modelos 1974 en adelante</p>	<p>Camión Dodge serie D 600 Modelos 1992 en adelante (clutch hidraulico)</p>

Dina

<p>HC-DINA</p>  <p>A-160592-27</p>
<p>Camioneta Dina 3200 con motor Perkins de 4 cil. y Dina 5121, con motor Perkins de 6 cil.</p>

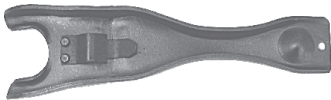
Ford

<p>HC-E7TZ</p>  <p>E7TZ-7515-A / Z7TA-7515-A</p>	<p>HC-72TY</p>  <p>B8C-7515A / 72TY-7515AA</p>	<p>HC-D8TZ</p>  <p>D8TZ-7515-A</p>
<p>Camioneta Ford F 450 Super Duty, Volante Plano (94 en adelante)</p>	<p>Camión Ford Serie 600 F, LN, C (1958-79)</p>	<p>Camioneta Van (75-79)</p>
<p>HC-D0TZ</p>  <p>D0TZ-7515A</p>	<p>HC-E4TZ</p>  <p>E4TZ-7515 C</p>	<p>HC-E0TZA</p>  <p>E0TZ-7515-A</p>
<p>Camioneta Ford series F-100 a F-350 americana con motor 300, 302, 351, 360, 390 y 400</p>	<p>Camionetas Ford, Van y Bronco (americanas) series F-100 a F-350 6 cil. en línea modelos 84 en adelante y (nacionales) V-6 modelos 85 en adelante</p>	<p>Camioneta Ford y Van, series F-100 a F-350 con motor 255, 300, 302, 351W (80-81), Van (80-82)</p>

2.1 Horquilla de clutch Clutch fork





Ford

<p>HC-E0TZB</p>  <p>E0TZ 7515 B</p> <p>Camioneta Ford series F-100 a F-350 con motor 400 (79-81) 351M (80-81)</p>	<p>HC-F81Z</p>  <p>F81Z-7515-AC</p> <p>Camioneta Ford F350 Super Duty y Tritón volante de caja (99 en adelante)</p>	<p>HC-Z5TA</p>  <p>Z5TA-7515-A</p> <p>Camioneta Ford F100, F150 y F350, modelos 1969 en adelante</p>
---	---	--

General Motors

<p>HC-GMCHEVY</p>  <p>90086134</p> <p>Chevy 99-07</p>	<p>HC-GM</p>  <p>340278 / 14066235</p> <p>Chevrolet con motor 292, 350, 231, 250, 262, 305 y 307</p>	<p>HC-GM2</p>  <p>15592270</p> <p>Camioneta Chevrolet y GMC, serie C, K y V motor 6 cil. 292 y motor V8 305, 350, 454 y 6.2L Diesel, modelos 1985 en adelante</p>
--	--	---

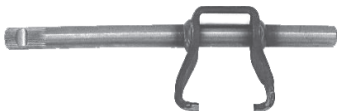







<p>HC-GM2H</p>  <p>15588262</p> <p>C, K, S10/S15 Transmisión Getrag (1988 - en adelante)</p>	<p>HC-GM3H</p>  <p>12385352</p> <p>C, K, S10/S15 Camionetas (92 en adelante)</p>	<p>HC-GM5</p>  <p>3765372 / 15687296</p> <p>P10 / 50, C50 (70 en adelante)</p>
--	--	--

<p>SHC-GM5</p>  <p>838987</p> <p>seguro</p>	<p>HC-GM6</p>  <p>93402800 / 14024930</p> <p>Cavalier, Celebrity, Citation V6 (1982-1986)</p>	<p>JBH-GM6</p>  <p>Jgo. De bujes Para HC-GM6</p>
---	---	---

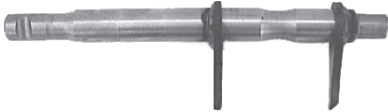

2.1 Horquilla de clutch Clutch fork



General Motors

<p>HC-GM 8</p>  <p>3765371 / 15687296</p> <p>Series 60 y 70 Motores 350,366 (73-91)</p>	<p>HC-GM27</p>  <p>15687298</p> <p>Series 60 & 70 motores 350,366 (91 en adelante)</p>	<p>HC-GM28</p>  <p>14070374</p> <p>S 10/15 transmisión Warner hidráulica 1984 en adelante</p>
<p>HC-GM29</p>  <p>15574633</p> <p>Chevrolet Kodiak, C6500,C7500 (90-02), 5 y 6 vel.</p>	<p>HC-GM61</p>  <p>8672090 / 8672942</p> <p>V6 Cavalier 5 vel (88-89) V6 II series (89 en adelante)</p>	<p>HC-GM62</p>  <p>8672937</p> <p>V6 Cavalier (87-88)</p>
<p>HC-GM63</p>  <p>8672510</p> <p>V6 Cavalier 5 vel (89 en adelante)</p>	<p>HC-GMATIZ</p>  <p>OEM# 96325013</p> <p>Pontiac Matiz L4 1.0L (04-07)</p>	

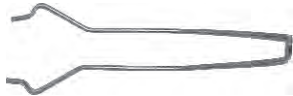
Nissan

<p>HC-DATSUN</p>  <p>30531-B5050</p> <p>Automóvil modelos 74-83 y camioneta todos los modelos D21 incluye seguro. Nissan Urvan 2.4L (02-08), Pick Up D22 (08-14)</p>	<p>SHC-DATSUN</p>  <p>L 130534-E 9000</p> <p>seguro</p>	<p>HC-NTSURU</p>  <p>30537-M8005</p> <p>Tsuru III (84-07)</p>
--	--	---

2.1 Horquilla de clutch Clutch fork



Nissan

HC-N1.6



30531-00QAA

Nissan Platina , Renault Kangoo
Megane (02-adelante)

Toyota

HC-THILUX



31204-35031

Toyota Hilux (05-09)
Toyota Hiace (06-12)

Volkswagen

HC-VWPOINTER



013 141 701

Pointer 97-07

HC-VWA3



02J 141 719C

Jetta A3, Seat Ibiza y
Eurovan (93-99)

HC-VWA4



















016 141 719A

Jetta A4 y Eurovan
(99-adelante)

















2.2 Tornillo horquilla de clutch Clutch ball studs



<p>THC-0</p> 	<p>THC-1</p> 	<p>THC-2</p> 	<p>THC-3</p> 
<p>Chevrolet 6 cilindros</p>	<p>Chevrolet 6 cilindros Juego completo</p>	<p>Dodge (71-74)</p>	<p>633238 Camión Dodge Serie D 600 rosca hembra</p>
<p>THC-3M</p> 	<p>THC-3J</p> 	<p>THC-4</p> 	<p>THC-5</p> 
<p>Tornillo macho para THC-3</p>	<p>Camión Dodge Serie D600 juego completo</p>	<p>A-181 Willys Jepp</p>	<p>3898610 Chevrolet (62-72)</p>
<p>THC-6</p> 	<p>THC-6L</p> 	<p>THC-7</p> 	<p>THC-8</p> 
<p>3725240 Chevrolet 6 cilindros</p>	<p>Chevrolet Tornillo largo</p>	<p>3866568 Chevrolet (62-81)</p>	<p>Ford Falcon</p>
<p>THC-9</p> 	<p>THC-10</p> 	<p>THC-11</p> 	<p>THC-11L</p> 
<p>Camioneta Ford Series F-150, F-250 y F-350 modelos 1980-adelante</p>	<p>Camioneta Dodge rodado sencillo y doble. Tornillo soporte de maroma o balancin</p>	<p>7522-A Camión Ford F-600</p>	<p>Camión Ford F-600 Mod. 1981 en adelante</p>



2.2 Tornillo horquilla de clutch Clutch ball studs



<p>THC-12</p> 	<p>THC-12L</p> 	<p>THC-13</p> 	<p>THC-13 LC</p> 
<p>Camión Dodge Serie D 600. Tornillo soporte de maroma o balancín</p>	<p>Camión Dodge Serie D 600 Tornillo soporte de maroma o balancín largo</p>	<p>3729000 Automóvil Chevrolet</p>	<p>15592268 Camioneta Chevrolet C-15 y C-35 modelos 1987 en adelante (clutch hidráulico)</p>
<p>THC-14</p> 	<p>THC-15</p> 	<p>THC-16</p> 	<p>THC-17</p> 
<p>4210696 Automóvil Dodge y camioneta D150 6 cilindros, modelos 1982 en adelante. Tornillo para la campana de clutch</p>	<p>421095 Automóvil Dodge y camioneta D150 8 cilindros, modelos 1982 en adelante, tornillo para la campana de clutch</p>	<p>Camioneta Chevrolet modelos 1975-1987</p>	<p>30537K20G0 Automóvil Datsun modelos 1974 a 1983 y camionetas Datsun y Nissan todos los modelos /A-10)</p>
<p>THC-18</p> 	<p>THC-18 E</p> 	<p>THC-19</p> 	<p>THC-GM2 H</p> 
<p>F7TZ-TB60-2A Camioneta Ford Clutch hidráulico 90 en adelante</p>	<p>Camioneta Ford (Clutch hidráulico) 90 en adelante con estriado (moleteado)</p>	<p>E3TZ-TB60 2A Microbus Ford (Clutch hidráulico) 90 en adelante</p>	<p>15552866 Camioneta Chevrolet sencilla y doble rodado C-15, C-25 y C-35 modelos 1992 en adelante (clutch hidráulico)</p>
<p>THC-20</p> 	<p>THC-21</p> 	<p>THC-22</p> 	<p>THC-23</p> 
<p>General Motors GM S-10 12545771</p>	<p>General Motors GM S-10 Blazer 15679715</p>	<p>General Motors Kodiak 00-02</p>	<p>14036058 General Motors Astro 85-89, Camaro 82-92, Pontiac Firebird 82-92</p>



2.2 Tornillo horquilla de clutch Clutch ball studs





<p>THC-24</p> 	<p>THC-25</p> 	<p>THC-26</p> 
<p>23049797 General Motors Chevrolet y GMC Pick ups Serie C/K 1500 y 2500 88-95</p>	<p>31236-35030 Toyota Hilux (05-09)</p>	<p>30537-0H601 Nissan Urvan (00-11)</p>

2.3 Maromas o balancines Bellcrank

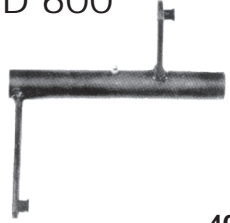
Chrysler

<p>MOB-D 100</p>  <p>J036457</p>	<p>MOB-D 150</p>  <p>4210692</p>	<p>MOB-D 600</p>  <p>4036473</p>
<p>Camioneta Dodge serie D 100 Modelos 1965-1980</p>	<p>Camioneta Dodge series D 150 y D 350 Modelos 1981-1989</p>	<p>Camión Dodge serie 600, modelos 1974 en adelante</p>



Ford

<p>MOB-F 100</p>  <p>78TY7528AA</p>	<p>MOB-F 150</p>  <p>83TM-7528B</p>	<p>MOB-F 600</p>  <p>C7TZ-7A572A</p>
<p>Camioneta F 100 hasta modelo 1979</p>	<p>Camioneta Ford series F 150, F 200 y F 350 modelos 1980 en adelante</p>	<p>Camión Ford serie F-600</p>





2.3 Maromas o balancines Bellcrank







General Motors

<p>MOB-GM</p>  <p>340607</p>	<p>MOB-GM2</p>  <p>14053618 / 330102</p>
<p>Camioneta rodado sencillo y doble modelos 1976-1987</p>	<p>Microbús C-30, P-30 modelos 1982 en adelante</p>





2.4 Tornillo o varilla de ajuste para horquilla de clutch Clutch Push Rod





<p>T-1</p>  <p>3820105</p>	<p>T-2</p>  <p>3820105</p>	<p>T-3</p>  <p>2830860</p>	<p>T-4</p>  <p>3748078</p>
<p>Camión Chevrolet Series 50,60 Diám. 9.4 mm (3/8") Longitud 370 mm (14 5/8")</p>	<p>Camión Dodge cil. secundario serie 500 y 600 con frenos hidráulicos. Diám. 9.4 mm (3/8") Longitud 125 mm (4 15/16")</p>	<p>Automóvil y Camioneta Dodge maquina 170 y 225 Diám. 9.4 mm (3/8") Longitud 141 mm (5 9/16")</p>	<p>Camión Dodge cil. Secundario Series 500 y 600 con frenos hidraulicos</p>

<p>T-5</p>  <p>DOTZ-7521-D</p>	<p>T-6</p>  <p>30614-38</p>	<p>T-6L</p> 	<p>T-7</p>  <p>43066-88</p>
<p>Camión Ford series F y B 600 modelos 1967 en adelante, longitud 315 mm (12 7/16") Diám. 9.4 mm (3/8")</p>	<p>Clutch Superior Longitud 197 mm (7 11/16")</p>	<p>Clutch Superior Longitud 181 mm (7 1/8")</p>	<p>Clutch inferior Longitud 181 mm (7 1/8")</p>





2.5 Templadores, ajustes, porta horquillas de clutch y seguros- Clutch linkage rod



CUADRO DE AJUSTE DE CLUTCH		PERNO DE HORQUILLA	MARIPOSA	HORQUILLA
CAC-1  3918467	CAC-1 C/R  3918467 C/R	PH-1 	M-1  3765322	H-1  6359-38
Cuadro de ajuste para varilla de clutch Camioneta Chevrolet Series 10,20,30 y Automóvil Rambler		Perno para Horquilla H-1 Diám. 9.4 mm (3/8")	Mariposa para varilla empuje Horquilla Clutch Chevrolet	Horquilla para perno de bomba de clutch superior. Camión Dina Series 3000, 3200, 531, 631 y 661 todos los modelos

PORTAHORQUILLA DE CLUTCH		SEGURO PORTACOLLARIN	SEGURO PARA MAROMA
CHP-1  2961312	CHP-2  2800848	SAP-D 531 	SAM-D150  SAM-D150
Modelos 1973 en adelante	Modelos 1963 a 1972	Seguro de alambre para portacollarín Camión Dina 531	Seguro para Maroma Dodge D100, D150















TEMPLADOR DE CLUTCH

TC-1  3659187	TC-2  3676454
Automóvil y camión Chevrolet	Automóvil Chevrolet y camionetas Panel
TC-3  906146	TC-4  906158
Willys Jeep, todos los modelos	Ajuste de clutch Willys Jeep, todos los modelos

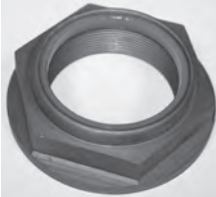
3.1 Tuercas para caja de velocidades Gearbox nuts

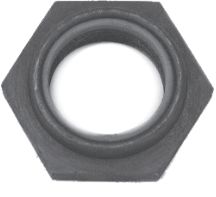







Tuercas para flecha de salida de la caja de velocidades con inserto de nylon

<p>TCV-18</p> 	<p>TCV-18F</p> 	<p>TCV-20</p> 	<p>TCV-20F</p> 
<p>Rosca: Standard Diámetro: 1 3/4" Caja Spicer fase I (7,10 y 14 vel.)</p>	<p>Rosca: Fina Diámetro: 1 3/4" Caja Spicer fase II (7,10 y 14 vel.)</p>	<p>Rosca: Standard Diámetro: 1 1/4" Flecha deslizable Dina 600</p>	<p>Rosca: Fina Diámetro: 1 1/4" Piñon Dina 531</p>
<p>TCV-21</p> 	<p>TCV-21F</p> 	<p>TCV-22F</p> 	<p>TCV-23F</p> 
<p>Rosca: Standard Diámetro: 1 1/2"</p>	<p>Rosca: Fina Diámetro: 1 1/2"</p>	<p>Rosca: Fina Diámetro: 1"</p>	<p>Rosca: Fina Diámetro: 2"</p>
<p>TCV-23FC</p> 	<p>TCV-24</p> 	<p>TCV-24F</p> 	<p>TCV-25F</p> 
<p>Rosca: Fina Diámetro: 2"</p>	<p>Rosca: Standard Diámetro: 1 1/8"</p>	<p>Rosca: Fina Diámetro: 1 1/8"</p>	<p>Rosca: Fina Diámetro: 1 5/8"</p>
<p>TCV-26</p> 	<p>TCV-27F</p> 	<p>TCV-33</p> 	
<p>Rosca: Standard Diámetro: 1 7/8"</p>	<p>Rosca: Fina Diámetro: 1 3/8"</p>	<p>Rosca: Izquierda</p>	

3.1 Tuercas para caja de velocidades Gearbox nuts



Tuercas de campana

<p>TCM-28</p>  <p>Rosca: Standard Diámetro: 1 1/4"</p>	<p>TCM-28F</p>  <p>Rosca: Fina Diámetro: 1 1/4"</p>	<p>TCM-29</p>  <p>Rosca: Standard Diámetro: 1 1/2"</p>
<p>TCM-29F</p>  <p>Rosca: Fina Diámetro: 1 1/2"</p>	<p>TCM-30</p>  <p>Rosca: Standard Diámetro: 1 3/4"</p>	<p>TCM-30F</p>  <p>Rosca: Fina Diámetro: 1 3/4"</p>



Visita nuestra pagina
www.lodi.com.mx

Soporte Técnico
01 800 227 5634

 **LODI Industrias Automotrices**

 **@IALodi**

4.1 Arañas, guasas y tuercas de housing

Rear axle hardware



JTA-1



AH-1
3663659
Int. 51 mm (2")



GH-1
3663658
Int. 51 mm (2")
Ext. 66 mm (2 1/2")



TH-1
3663657

Camioneta Chevrolet rodado sencillo



AH-2
473692
Int. 55 mm (2 5/32")



GH-2
473628
Int. 54 mm (2 1/8")
Ext. 80 mm (3 5/32")



TH-2
473636

Camioneta Chevrolet doble rodado



AH-3
3703703
Int. 63.5 mm (2 1/2")



GH-3
3703704
Int. 64 mm (2 33/64")
Ext. 97 mm (3 53/64")



TH-3
3703711

Camión Chevrolet Series 500 y 600

JTA-4



AH-4
1925818
Int. 67 mm (2 21/32")



TH-4
4032402
Int. 2 5/8"

Camión Dodge Serie D 600 con frenos de aire 67678-R, modelos 1974 en adelante; Camión Dina 531 y 5121; International y para todo tipo de Camión con diferencial de 18,500 Lbs.

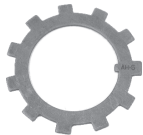

AH-5
2229883
Int. 64 mm (2 33/64")



TH-5
4032401

Camión Dodge Series D 500 y D 600 con frenos hidráulicos 36415-H hasta el modelo 1973, Camión International Series R y L y para todo tipo de camión con diferencial de 15,000 y 17,000 Lbs

JTA-6



AH-6
B6Y-1124-A
Int. 52 mm (2 1/64")



TH-6
B6Y-4252-A

JTA-6N



TH-6 N
D 5UZ-4255-A
(con candado de Nylon)
Modelos 1980 en adelante

Camioneta Ford F 350 doble rodado

JTA-7A



AH-7 A
B4T-1124
Int. 64.15 mm (2 17/32")



TH-7 C/P
B4T-4255
(con perno)
Int. 2 1/2"



TH-7
B4T-4258
Int. 2 1/2"

Camión Ford Series 500 y 600



AH-8
36416-H
Int. 63.5 mm (2 1/2")



TH-8
53395-H
Int. 2 1/2"



TH-8 C/R
53395-H
(con reten)
Int. 2 1/2"

Camión International Series R y L 160,170 y 180

JTA-9



AH-9
2909259
Int. 51 mm (2")



TH-9
2909258

Camioneta Dodge Series D300 doble rodado



AH-10
61-1124 A
Int. 46 mm (1 13/16")



TH-10
61-4252 A
Int. 1 13/16"

Camioneta Ford F 250 todos los modelos y Dodge Serie W-300

JTA-12



AH-11
90180
Int. 76 mm (3")



TH-11
31926
Int. 3"



TH-11 C/R
31926
(con reten
Int. 3")

Camiones Dina 631, Peña, Ramirez e International con diferencial Eaton 38 D y R 200



AH-12
90181
Int. 82.5 mm
(3 1/4")



TH-12
31927
Int. 3 1/4"

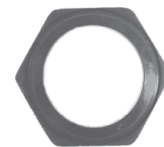

TH-12 C/R
31927
(con reten)
Int. 3 1/4"

Camiones Dina Serie 861, Kenworth, Autobus Masa Somex, White, Peña y Ramirez con diferencial Eaton 44 D y R 220

4.1 Arañas, guasas y tuercas de housing Rear axle hardware



JUEGOS DE HOUSING

	PIEZA	CANT	PIEZA	CANT	PIEZA	CANT	PIEZA	CANT
JTA-1	TH-1	2	GH-1	1	AH-1	1	EMP-1	1
JTA-4	TH-4	2			AH-4	1	EMP-4	1
JTA-6	TH-6	2			AH-6	1	EMP-6	1
JTA-6N	TH-6N	1	JTA-6NS	1			EMP-6	1
JTA-7A	TH-7	1	TH-7C/P	1	AH-7	1	EMP-7	1
JTA-9	TH-9	2			AH-9	1	EMP-9	1
JTA-12	TH-12	2			AH-12	1	EMP-12/13	1
JTA-13A	TH-13	1	TH-13C/P	1	AH-13A	1	EMP-12/13	1
JTA-1415	TH-14	1	TH-15	1	AH-1415	1		
JTA-1415A	TH-14	1	TH-15C/P	1	AH-1415A	1		
JTA-1415AZ	TH-14	1	TH-15C/P	1	AH-1415A	1	AH-1415	1
JTA-21	TH-21	1	TH-22C/P	1	AH-22A	1		

JTA-13A



AH-13A
Int. 83.4 mm
(3 9/32")



TH-13 C/P
1227 N-517
(con perno)



TH-13
1227 N-517
Int. 3 1/4"

Camionetas Dina, Kenworth y Autocar con diferencial Rockwell SQDD, SQHD y SSHD

JTA-1415 Juego de tres piezas

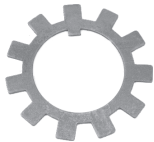

AH-1415
Int. 67.07 mm
(2 41/64")



TH-14
(tuerca octagonal)
Eje Sudisa



TH-15
(tuerca octagonal)
Int. 2 5/8"

JTA-1415 A Juego de tres piezas



AH-1415A
Int. 67.07 mm
(2 41/64")



TH-14
(tuerca octagonal)
Int. 2 5/8"



TH-15 C/P
(tuerca octagonal)
Int. 2 5/8"

Eje Sudisa con Perno **JTA-1415AZ**
AH-1415



TH-17
Eje delantero
Kenworth perno recto.
Int. 2 1/4"



TH-19
International
Int. 2 1/16"



AH-20

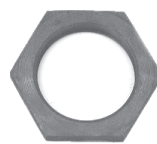

TH-20
Eje ligero Sudisa



AH-MB
470422C91
Camiones Mercedes Benz
Todos los modelos con
eje Eaton



TH-0
Willys



TH-16
Dodge 600
Int. 2 5/8"

JTA-21 Juego de tres piezas



AH-22A
Int. 3 1/2"



TH-21
Int. 3 1/2"









TH-22 C/P
Int. 3 1/2"

eje Fruehauf

4.1 Arañas, guasas y tuercas de housing Rear axle hardware



SEGUROS PARA BALERO DE RUEDA TRASERA

<p>SB-1</p> 	<p>SB-2</p> 	<p>SB-3</p> 	<p>SB-4</p> 
<p>Automoviles, Chevelle, Opel, Rambler, Datsun y Valiant con diferencial del país, para baleros SET 9 U298-261 y 48548-A y Tasa 48511 A. Int. 34.84 mm (1 23/64") Espesor 13 mm (1/2")</p>	<p>Camionetas Chevrolet y Dodge con diferencial del país, para baleros SET 10 U399-360 201047 y Tasa 201011. Int.39.62 mm (1 9/16")</p>	<p>Camioneta Ford Serie F 100 para Balero 88128. Int. 38.76 mm (1 17/32") Espesor 9.4 mm (3/8")</p>	<p>8A-1180 Automóvil Ford, para Baleros 88107, RW207CC, Rw307, Rw507 y Rw607. Int. 34.94 mm (1 3/8") Espesor 9.4 mm (3/4")</p>
<p>SB-5</p> 	<p>SB-6</p> 	<p>SB-7</p> 	
<p>Automóviles Ford y Dodge Para baleros RW-34R. Int. 33.94 mm (1 21/64") Espesor 7.9 mm (5/16")</p>	<p>Automóvil Ford para baleros RW-206 VR y RW 506 Int. 31.76 mm (1 1/4") Espesor 8.52 mm (21/64")</p>	<p>Pick ups Chevrolet (86-04), Pick ups Nissan (95->) Para balero SET80 U497 (9A4A3) / K444658</p>	



LODI Industrias Automotrices

www.lodi.com.mx



SINCE 1969

**SEGURIDAD TOTAL
EN EL CAMINO**



LODI Industrias Automotrices
Dale Like !

www.lodi.com.mx

5.1 Soportes para barra de cardán Drive shaft support



GUARDA POLVOS GALVANIZADO CAL. 18



GP-107
Para baleros
88107



GP-508
Para baleros
88508



GP-509
Para baleros
88509



GP-510
Para baleros
88510



GP-512
Para baleros
88512

BALERO

BALERO CON GUARDAPOLVO



B-4



B-107



B-508



B-509



B-510



B-512

HULES



HS-4



HS-107



HS-N2.4



HS-508

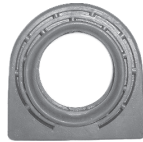

HS-509



HS-510

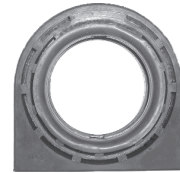

HS-512

SOPORTES CON HULES



BC-4



BC-107



BC-508



BC-509



BC-510







BC-512

Soportes completos disponibles en caja, para pedirlos solo agregue una "C" al final del código

5.1 Soportes para barra de cardán Drive shaft support





Uso general

<p>BC-107 R</p>  <p>Con balero 88107 Varios GM, Dodge, Ford Camionetas Int. 1 3/8"</p>	<p>BC-508 R</p>  <p>Con balero 88508 Varios GM, Dodge, Ford 3 1/2 Ton. Int. 1 9/16</p>	<p>BC-509 R</p>  <p>Con balero 88509 Dodge, Dina, Camiones</p>
<p>BC-510 R</p>  <p>Con balero 88510 Varios GM, Dodge, Ford Camiones</p>	<p>BC-512 R</p>  <p>Con balero 88512 Varios GM, Dodge, Ford camiones grandes</p>	

Chrysler / Dodge

<p>BC-88536</p>  <p>Dodge Ram 1500, 2500, 3500 (00-04), Dodge Dakota (00-02) Diámetro int. 40 mm</p>

Ford

<p>BC-RAR</p>  <p>Ford Ranger (86-89) Int. 1 1/4"</p>	<p>BC-RNR</p>  <p>Ford Ranger (90-adelante) Int. 1 3/16"</p>
--	--



5.1 Soportes para barra de cardán Drive shaft support



General motors

<p>BC-4R</p>  <p>Con balero 6206-ZZ GM Antiguos</p>	<p>BC-88505</p>  <p>Chevrolet Van Express 2500, 3500 (00-02)</p>	<p>BC-88530</p>  <p>Silverado 1500 2WD (00-04) Blazer S10 (94-00), Diám int. 35 mm</p>
<p>BC-88540</p>  <p>Silverado 1500, 2500, 3500 (00-04) (con eje extendido)</p>	<p>BC-GS 10</p>  <p>GM S10 (89-96) Int. 1 9/16"</p>	<p>BC-GMLUVR</p>  <p>GM Chevy Luv (72-84)</p>
<p>BC-IS2WDR</p>  <p>Isuzu Rodeo (91-97), GM Colorado (05-10)</p>		

Honda

<p>BC-10003</p>  <p>Honda CR-V (97-01)</p>	<p>BC-HB32</p>  <p>Honda Passport 4WD (94-98)</p>
---	--

5.1 Soportes para barra de cardán Drive shaft support



Isuzu

BC-1280-60



Isuzu Pick Ups (88-95) ,
Trooper (88-91)
Rodeo 2WD (89-adelante)

BC-2390-10



Isuzu Trucks ELF

BC-9720



Isuzu Luv 4WD (72-89)

BC-HB33



Isuzu Trooper (92-95)

Mazda

BC-MAB2000R



Mazda Pick Up
(85-adelante)

BC-MAB1600R



Mazda Pick Ups
(77-84)

BC-MAB2600R



Mazda B2600, B3000
(91-adelante)

BC-MABT50



Mazda B2200 (90-adelante),
B2500 (96-00), BT-50 (07-09)

BC-MAT3000



Mazda B2200 2WD (82-87)

5.1 Soportes para barra de cardán Drive shaft support



Mercedes Benz

BC-HB4574



Mercedes Benz
Sprinter (00-06)

Mitsubishi

BC-HB14



Mighty Max (83-88),
Dodge Ram 50 (85-88)

BC-HB22



Mighty Max 2WD (90-92)
Pick Up L200 2WD (87-01)

BC-HB30



Montero Sport (97-04)
Dodge Ram 50 (87-91)

BC-MMAXR



Mitsubishi (83-88)

Nissan

BC-306R



Nissan Americana 2.4L
Int. 1 3/16

BC-33G25



Pathfinder 4WD (87-95)
Pick D21 4WD (86-95)

BC-36G25



Nissan Pick ups 4WD
(87-adelante)



5.1 Soportes para barra de cardán Drive shaft support



Nissan

<p>BC-41L25</p>  <p>Nissan Pick ups (84-95) Nissan Xterra</p>	<p>BC-J2100</p>  <p>Nissan Pick ups 4WD (89-adelante)</p>	<p>BC-N720R</p>  <p>Nissan Pick Up 720 (80-86) (BAJO)</p>
<p>BC-N2.4R</p>  <p>Nissan Pick Up 2.4L (92-adelante)</p>	<p>BC-NDAR</p>  <p>Nissan Pick Up (84-95) Maxima (82-84), Infiniti M30 (90-93) (Doble Anillo)</p>	<p>BC-NUSR</p>  <p>Nissan Pick Up (USA) (73-90) (ALTO)</p>
<p>BC-NP4R</p>  <p>Nissan Pick Ups, Pathfinder 4X4 (86-95)</p>		

Toyota

<p>BC-OK020</p>  <p>Hilux 4WD (04-adelante)</p>	<p>BC-1600-10</p>  <p>Toyota RAV4 (96-00)</p>	<p>BC-1820-10</p>  <p>HiLux 2WD (04-adelante)</p>
--	---	--

5.1 Soportes para barra de cardán Drive shaft support



Toyota

BC-2380-40



Tacoma 2WD (95-03)
Hiace (07-14)

BC-36063



Toyota Trucks (78-92)

BC-HB26



Toyota T100 2WD (93-98)

BC-HB27



Toyota 4Runner (89-95)

BC-HB28



Toyota T100 4WD (94-98)

BC-HB31



Toyota Tacoma 4WD (95-03)

BC-HB7



Celica (82-85), Supra (85-88),
Tercel (83-88)

BC-HB8



Toyota Pick ups 2WD (84-90)

BC-HB9



Toyota Pick ups (91-95)

BC-T2WAR



Toyota Pick Ups 4X2 (79-93)

BC-T4WAR



Toyota Pick Up 4X4 (79-93)

BC-TRN20R



Toyota Pick Ups RN20 (73-75)

5.1 Soportes para barra de cardán Drive shaft support



Toyota

BC-TRN25R



Toyota Pick Up RN25 (79-80)

MAX By **LODI**
performance

**BOMBAS DE GASOLINA
PARA UN ENCENDIDO PERFECTO**



100% Garantizado!

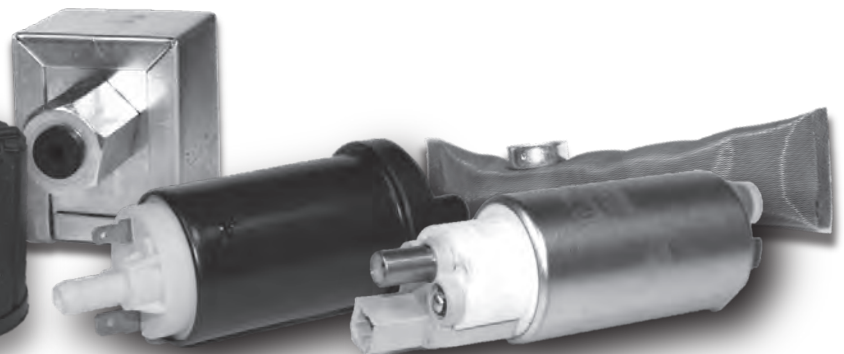

Soporte Técnico
01 800 227 5634

LODI Industrias Automotrices

@IALodi

6.1 Tablas de equivalencias

Filtro y empaque de transmisión automática



FRAM #	LODI #
FT-1013A	FC-TH400A
FT-1015	FC-TF6CH
FT-1017	FC-PWRGLIDE
FT-1019A	FC-TH425
FT-1020	FC-TH400
FT-1020A	FC-TH400L
FT-1021	FC-TH350NY
FT-1024	FC-FMX
FT-1025	FC-C6A
FT-1027	FC-C4A
FT-1028	FC-C4
FT-1033A	FC-TH350C
FT-1034	FC-AT540
FT-1035	FC-C4N
FT-1036	FC-TH200L
FT-1037	FC-C6N
FT-1038	FC-C3
FT-1039	FC-TF6/8
FT-1039	FC-TF8
FT-1040	FC-BWT35
FT-1042A	FC-FMXF
FT-1043	FC-A404F
FT-1044	FC-3N71A
FT-1045	FC-A41
FT-1046	FC-3N71A
FT-1047	FC-TH125
FT-1048	FC-TH200NY
FT-1050	FC-TH180
FT-1051A	FC-MT640
FT-1053	FC-TF6G
FT-1054A	FC-C4D
FT-1055	FC-C6
FT-1056	FC-FIOD
FT-1057B	FC-TH200R4
FT-1057C	FC-TH700A
FT-1058	FC-ATX
FT-1059	FC-C5
FT-1060	FC-M41
FT-1060	FC-M41A
FT-1061	FC-VW010
FT-1062A	FC-TH325N
FT-1063	FC-TH325
FT-1064	FC-C54
FT-1065	FC-A404M
FT-1066	FC-A40D
FT-1068	FC-F3AE
FT-1068	FC-F3AM
FT-1069	FC-TSURU
FT-1070	FC-KM171
FT-1070	FC-KM170
FT-1071	FC-A55F
FT-1072	FC-TH440N
FT-1073	FC-AXOD
FT-1073A	FC-AX4S
FT-1073B	FC-AX4S
FT-1074	FC-TH700N
FT-1076	FC-ZF4HP22
FT-1077	FC-A240E
FT-1083	FC-A340E
FT-1084	FC-MX1
FT-1086	FC-FIOD4
FT-1087	FC-A4LDE4
FT-1088	FC-A4LDA

FRAM #	LODI #
FT-1092	FC-JATCO
FT-1094	FC-R4AXELA
FT-1099	FC-A43D
FT-1100	FC-ZF3HP22
FT-1102	FC-AW4
FT-1103	FC-L4N71B
FT-1104	FC-4EATG
FT-1105	FC-A340H
FT-1106	FC-KM177
FT-1110	FC-MX17
FT-1111	FC-JF403E
FT-1112	FC-A42DL
FT-1113	FC-RL3F01A
FT-1115	FC-A4LDE
FT-1115A	FC-A4LDE
FT-1119	FC-F3A
FT-1121	FC-A43DE
FT-1122	FC-A604
FT-1123	FC-4EAT
FT-1124	FC-RE4R03A
FT-1128	FC-A55F4
FT-1129	FC-TH700E6
FT-1130	FC-E4OD4W
FT-1131	FC-C6E
FT-1132	FC-A440FD
FT-1133	FC-KM175
FT-1134	FC-4L80E
FT-1137	FC-A141L
FT-1138	FC-R4AEL
FT-1139	FC-E4N71B
FT-1140	FC-G4AHL
FT-1141	FC-A606
FT-1142	FC-A540E
FT-1143	FC-4EATGN
FT-1144	FC-FIODE
FT-1145	FC-4R01A4W
FT-1146	FC-TH700E
FT-1149	FC-4L30E6
FT-1150	FC-R4AXELN
FT-1151	FC-4F04A
FT-1152	FC-F3AF
FT-1153	FC-F4A33
FT-1154	FC-KM176A
FT-1154	FC-KM176N
FT-1158	FC-SENTRA
FT-1159	FC-JF403N
FT-1161	FC-F3AATX
FT-1162	FC-A245E
FT-1164	FC-AX4N
FT-1166	FC-4T40E
FT-1167	FC-FIOD4E
FT-1169	FC-A141E
FT-1170	FC-4L30E
FT-1172	FC-4T80E2
FT-1181	FC-U140E
FT-1185	FC-A340
FT-1186	FC-VWAG4
FT-1187	FC-5HP19
FT-1191	FC-A341E
FT-1193	FC-A4AF1
FT-1193	FC-F4A21
FT-1194	FC-4R01A2W
FT-1194	FC-4R01AP

FRAM #	LODI #
FT-1196	FC-A541E
FT-1197	FC-A340F
FT-1201	FC-4L60E
FT-1203	FC-4L80ER2
FT-1206	FC-44RE
FT-1210	FC-4F27E
FT-1211	FC-MPWA
FT-1214	FC-W5A580
FT-1215	FC-4F04A
FT-1216	FC-A340F4
FT-1217	FC-4L60EB
FT-1218	FC-MPYA
FT-1219	FC-M4VA
FT-1220	FC-U341E
FT-1222	FC-45RFE
FT-1223	FC-45RFE4
FT-1224	FC-5R55W
FT-1225	FC-A4AF
FT-1226	FC-5R110W
FT-1227	FC-5R110WCA
FT-1228	FC-L1000
FT-1229	FC-L1000A
FT-1230	FC-4L60EA
FT-1232	FC-U151E
FT-1233	FC-42RLEA
FT-1235	FC-A246E
FT-1236	FC-6R60
FT-1238	FC-6L90
FT-1239	FC-5R110WN
FT-1240	FC-62TE
N / D	FC-6T70
N / D	FC-A46DE
N / D	FC-AW450
N / D	FC-AXODA
N / D	FC-B7XA
N / D	FC-BAXA
N / D	FC-BDGA
N / D	FC-BVLA
N / D	FC-C6EP
N / D	FC-CFT30
N / D	FC-DPO
N / D	FC-F4A41A
N / D	FC-FNR5
N / D	FC-JF506E
N / D	FC-MPJACA
N / D	FC-RE4F04B
N / D	FC-RE5R05A
N / D	FC-SLYA
N / D	FC-SPCA
N / D	FC-TF81SC
N / D	FC-VW09D
P6646	FC-TAATCA
P9264	FC-L1000CA
PH9688	FC-F4A411CA

6.1 Tablas de equivalencias

Filtro y empaque de transmisión automática



CHROMITE #	LODI #
JT-201	FC-A404F
JT-202	FC-A604
JT-203	FC-A404M
JT-206	FC-TF8
JT-206A	FC-TF6G
JT-207	FC-TF6CH
JT-207A	FC-TF8CH
JT-208	FC-TF6/8
JT-209	FC-A606
JT-210	FC-44RE
JT-211	FC-45RFE
JT-211A	FC-45RFE4
JT-211SO	FC-45RFECA
JT-212	FC-AW4
JT-213	FC-A4AF
JT-214	FC-42RLEA
JT-215	FC-42RLE
JT-217	FC-62TE
JT-301	FC-A4LDR
JT-301A	FC-A4LDA
JT-301B	FC-A4LD
JT-302	FC-FIOD
JT-302A	FC-FIOD4
JT-303	FC-AXODA
JT-303A	FC-AXOD
JT-303B	FC-AX4N
JT-304	FC-ATX
JT-305	FC-C3
JT-306	FC-C4N
JT-307	FC-C4
JT-308	FC-C5
JT-309	FC-C6A
JT-310	FC-C6N
JT-311	FC-FMX
JT-311A	FC-FMXF
JT-312	FC-FIODE
JT-312A	FC-FIOD4E
JT-313	FC-4EAT
JT-313A	FC-F4AEL
JT-314	FC-E40D4WP
JT-314A	FC-C6EP
JT-314AF	FC-C6E
JT-314F	FC-E40D4W
JT-315	FC-CD4E
JT-316	FC-A4LDE
JT-316A	FC-A4LDE4
JT-317	FC-4F27E
JT-317A	FC-FNR5
JT-318	FC-C54
JT-319	FC-5R55N
JT-320	FC-5R55W
JT-321	FC-4EATG
JT-322	FC-4EATGN
JT-323	FC-F3A
JT-323	FC-F3AE
JT-324	FC-C6
JT-325	FC-C4D
JT-326	FC-C4A
JT-327	FC-F3AF
JT-328	FC-F3AATX
JT-329	FC-5R55S
JT-330	FC-5R110W
JT-330C	FC-5R110WCA

CHROMITE #	LODI #
JT-331	FC-6R60
JT-332	FC-JF506E
JT-333	FC-CFT30
JT-335	FC-CFT23
JT-336	FC-TF81SC
JT-337	FC-5R110WN
JT-340	FC-6F35
JT-401	FC-TH125
JT-401A	FC-TH125
JT-402	FC-TH180
JT-403	FC-TH200L
JT-404	FC-TH200R4
JT-405	FC-TH200NY
JT-406	FC-TH350NY
JT-407	FC-TH350L
JT-408	FC-TH400
JT-408A	FC-TH400L
JT-409	FC-TH440N
JT-409A	FC-TH440N
JT-410	FC-TH700N
JT-411	FC-TH700A
JT-412	FC-TH700E6
JT-413	FC-TH700E
JT-413A	FC-TH700E8N
JT-413B	FC-4L60E
JT-414	FC-4T40E
JT-415	FC-4T80E
JT-415AB	FC-4T80E2
JT-416	FC-4L80E
JT-416A	FC-4L80ER2
JT-417	FC-PWRGLIDE
JT-418	FC-4L30E
JT-419	FC-4W60
JT-420	FC-4L30E6
JT-421	FC-A43DE
JT-422	FC-TH350C
JT-423	FC-TAAT
JT-423SO	FC-TAATCA
JT-424	FC-TH325
JT-424A	FC-TH325N
JT-425	FC-MX17
JT-426	FC-MX1
JT-427	FC-4L60EB
JT-428	FC-4L60EA
JT-429	FC-6L80
JT-430	FC-TH700EP
JT-431	FC-TH400A
JT-432	FC-TH425
JT-433	FC-JF403E
JT-435	FC-6T70
JT-437	FC-AW50
JT-438	FC-AW81
JT-439	FC-6L90
JT-440	FC-TH700E6
JT-441	FC-AW55
JT-442	FC-4T45E
JT-444	FC-6T40E
JT-446	FC-6L80E
JT-447	FC-VT25E
JT-501	FC-3N71A
JT-502	FC-JATCO
JT-503	FC-TSURU
JT-503A	FC-RL3F01A

CHROMITE #	LODI #
JT-503B	FC-RN3F01A
JT-504	FC-SENTRA
JT-505	FC-4F02A
JT-506	FC-4R01A4W
JT-506A	FC-4R01AP
JT-506B	FC-4R01A2W
JT-507	FC-4F04A
JT-508	FC-4F04A
JT-509	FC-4F04AN
JT-510	FC-RE5R05A
JT-511	FC-RE4R03A
JT-512	FC-JR503E
JT-513	FC-AW55
JT-514	FC-RE4F04B
JT-515	FC-JF010E
JT-516	FC-RE4F03V
JT-517	FC-RE0F10A
JT-518	FC-RE7R01A
JT-601	FC-VW010
JT-601A	FC-VW010A
JT-602	FC-VW095
JT-603	FC-VWAG4
JT-604	FC-VW098
JT-605	FC-5HP19
JT-606	FC-VW010E
JT-609	FC-VW09D
JT-610	FC-VW003
JT-612	FC-VW01J
JT-617	FC-4HP18FLA
JT-619	FC-VW09E
JT-620	FC-VW02E
JT-621	FC-VW02EN
JT-622	FC-ZF6HP19A
JT-623	FC-VW09G
JT-624	FC-ZF8HP45
JT-625	FC-VW09M
JT-7000	FC-A343F
JT-7001	FC-A340F
JT-7002	FC-A340F4
JT-7003	FC-A340
JT-7004	FC-A540E
JT-7005	FC-A141E
JT-7006	FC-A541E
JT-7007	FC-A340H
JT-7008	FC-A43D
JT-7009	FC-A55F
JT-701	FC-MT640
JT-7010	FC-A55F4
JT-7011	FC-U341E
JT-7012	FC-A340E
JT-7013	FC-A245E
JT-7014	FC-A41
JT-7015	FC-A141L
JT-7016	FC-A240E
JT-7017	FC-A40D
JT-7018	FC-A42DL
JT-7019	FC-U140E
JT-7020	FC-A350E
JT-7021	FC-A240E
JT-7022	FC-A46DE
JT-7025	FC-A440FD
JT-7026	FC-A440F
JT-7027	FC-A341E

6.1 Tablas de equivalencias

Filtro y empaque de transmisión automática



CHROMITE #	LODI #
JT-7028	FC-A30
JT-7029	FC-A750E
JT-702F	FC-AT540
JT-703	FC-L1000
JT-7030	FC-A750F
JT-7032	FC-U660E
JT-7033	FC-U151E
JT-7035	FC-U540E
JT-7036	FC-A246E
JT-703A	FC-L1000A
JT-703SO	FC-L1000CA
JT-7100	FC-B7XA
JT-7101	FC-BAXA
JT-7101SO	FC-MPJACA
JT-7102	FC-MPXA
JT-7103	FC-M4TA
JT-7104	FC-MDLA
JT-7105	FC-A24A
JT-7106	FC-M4VA
JT-7107	FC-HONDA3
JT-7108	FC-ML4A
JT-7109	FC-M4VAP
JT-7110	FC-CVTH
JT-7112	FC-BDKA
JT-7113	FC-BVLA
JT-7114C	FC-BDGA
JT-7115	FC-G4
JT-7116	FC-MPWA
JT-7117	FC-HONDAMATIC
JT-7120	FC-MPYA
JT-7123	FC-MPRA
JT-7124	FC-APX4
JT-7127	FC-SLYA
JT-7128	FC-SZCA
JT-7129	FC-M7WA
JT-7130	FC-SMMA
JT-7130SF	FC-SMMACA
JT-7131	FC-M91A
JT-7132	FC-B97A
JT-7133	FC-MURA
JT-7134	FC-SPCA
JT-7135	FC-PN3A
JT-7143	FC-MV2A
JT-7200	FC-E4N71B
JT-7201	FC-F3AM
JT-7202	FC-F3AG
JT-7203	FC-4R01A4W
JT-7204	FC-GF4AEL
JT-7205	FC-3N71A
JT-7206	FC-L4N71B
JT-7207	FC-G4AHL
JT-7208	FC-JF403N
JT-7209	FC-4EATGN
JT-7211	FC-R4AEL
JT-7300	FC-F4A51D
JT-7301	FC-F1C1
JT-7302	FC-F4A51T
JT-7303	FC-V4A51
JT-7304	FC-KM171
JT-7304A	FC-KM170
JT-7305	FC-KM175
JT-7306	FC-KM177
JT-7307	FC-F4A33

CHROMITE #	LODI #
JT-7308	FC-KM176A
JT-7308	FC-KM176N
JT-7309	FC-A4AF1
JT-7310	FC-F4A21
JT-7311	FC-R4A51
JT-7312SO	FC-F4A411CA
JT-7313	FC-F4A41A
JT-7314	FC-F4A51A
JT-7500	FC-4L30E
JT-7502	FC-AW450
JT-7900	FC-4EATS
JT-7900SO	FC-4EATCA
JT-7901	FC-R4AXELN
JT-7902	FC-R4AXELA
JT-7907	FC-ECVT
JT-8000	FC-W5A580
JT-8001	FC-722
JT-8002A	FC-W4A040
JT-8003	FC-W4A020
JT-8004	FC-W5A030
JT-8005	FC-722.9
JT-8100	FC-4L30E6
JT-8101	FC-5L40E
JT-8102	FC-5L40EA
JT-8103	FC-5L40EB
JT-8104	FC-ZF4HP22
JT-8106	FC-ZF5HP18
JT-8107	FC-ZF5HP30
JT-8109	FC-ZF6HP26
JT-8110	FC-ZF6HP19
JT-8113	FC-6L45R
JT-8700	FC-DPO
JT-8800	FC-DPO
JT-8801	FC-MJ3
JT-8901	FC-4HP22R
N / D	FC-A650E
N / D	FC-AX4S
N / D	FC-BWT35
N / D	FC-BWT65
N / D	FC-BWT66
N / D	FC-F38CA
N / D	FC-F516CA
N / D	FC-HT700
N / D	FC-HT740
N / D	FC-HT750
N / D	FC-K4
N / D	FC-M101
N / D	FC-M41
N / D	FC-M41A
N / D	FC-W3A040
N / D	FC-W3A040N
N / D	FC-W4B025
N / D	FC-ZF3HP22
N / D	FC-ZF4HP14
N / D	FC-ZF4HP18
N / D	FC-A904
N / D	FC-A727

6.1 Tablas de equivalencias

Filtro y empaque de transmisión automática



OEM #	LODI #
FC-3N71A	31728-X3100
FC-42RLE	52852913AA
FC-42RLEA	52852913AB
FC-44RE	52118789
FC-45RFE	4800029AA
FC-45RFE4	4799507
FC-45RFECA	4799662
FC-4EAT	FU61-21-500B
FC-4EATCA	38325-AA032
FC-4EATG	FU01-21-500C
FC-4EATGN	FU50-21-500A
FC-4EATS	31728-AA050
FC-4F02A	31728-21X01
FC-4F04A	31728-80X04
FC-4F04AN	31397-80X01
FC-4F27E	XS4Z-7A098-AB
FC-4HP18FLA	01F-325-433
FC-4HP22R	1043-226-037
FC-4L30E	8-96841-011-0
FC-4L30E6	24111-218-899
FC-4L60E	24208574
FC-4L60EA	24225323
FC-4L60EB	24208813
FC-4L80E	8678757
FC-4L80ER2	24210956
FC-4R01A2W	31728-41X00
FC-4R01A4W	31728-48X01
FC-4R01AP	31728-41X02
FC-4T40E	24203770
FC-4T45E	24221762
FC-4T80E	8681416
FC-4T80E2	24207361
FC-4W60	26445-60G10
FC-5HP19	01V-325-429
FC-5L40E	24117-510-010
FC-5L40EA	24117-557-070
FC-5L40EB	24117-510-012
FC-5R110W	3C3Z-7A098-AA
FC-5R110WCA	3C3Z-7B155-BA
FC-5R110WN	8C3Z-7A098-D
FC-5R55N	WX4Z-7A098-BB
FC-5R55S	3W4Z-7A098-AA
FC-5R55W	1L2Z-7A098-AC
FC-62TE	05078555AA
FC-6F35	9L8P-7G186-CD
FC-6L45R	24117-593-565
FC-6L80	24236931
FC-6L90	24236933
FC-6R60	6L2Z-7A098-AA
FC-6T40E	24230708
FC-6T70	7T4Z-7A098-B
FC-722	168-377-0395
FC-722.9	220-277-0395
FC-A141E	35330-32022
FC-A141L	35330-32010
FC-A240E	35330-12020
FC-A245E	35330-12030
FC-A246E	35330-12040
FC-A24A	25420-P24-J01
FC-A30	35303-30013
FC-A340	35330-60020
FC-A340E	35330-30011
FC-A340F	35330-22010

OEM #	LODI #
FC-A340F4	35330-35020
FC-A340H	35303-35010
FC-A341E	35330-30020
FC-A343F	35330-60030
FC-A350E	35330-30040
FC-A404F	5212145
FC-A404M	4269649
FC-A40D	35303-30031
FC-A41	35303-22022
FC-A42DL	35303-14010
FC-A43D	35303-30050
FC-A43DE	35303-33060
FC-A440F	35330-60011
FC-A440FD	35303-60010
FC-A46DE	35303-35020
FC-A4AF	46321-22731
FC-A4AF1	46321-22050
FC-A4LD	E6TZ-7A098-A
FC-A4LDA	E6TZ-7A098-B
FC-A4LDE	E5TZ-7A098-A
FC-A4LDE4	E5TZ-7A098-B
FC-A4LDR	E9TZ-7A098-C
FC-A540E	35330-32030
FC-A541E	35330-33010
FC-A55F	35303-16020
FC-A55F4	35303-16030
FC-A604	4504048
FC-A606	4626449
FC-A650E	35330-30070
FC-A727	3621456
FC-A750E	35330-60050
FC-A750F	35330-60010
FC-A904	3515996
FC-APX4	25420-PX4-023
FC-AT540	6438326
FC-ATX	E1FZ-7A098-A
FC-AW4	83504032
FC-AW450	8-97202-067-0
FC-AW50	5164553
FC-AW55	31728-8Y000
FC-AW81	93741509
FC-AX4N	F6DZ-7A098-A
FC-AX4S	F3DP-7G186-AB
FC-AXOD	F5DZ-7A098-A
FC-AXODA	E6DZ-7A098-A
FC-B7XA	25420-P7X-003
FC-B97A	25420-R36-003
FC-BAXA	25420-PAX-003
FC-BDGA	25450-RAY-003
FC-BDKA	25420-RPC-003
FC-BVLA	25420-RDP-003
FC-BWT35	3179973
FC-BWT65	24311-207-076
FC-BWT66	3188896
FC-C3	D4ZZ-7A098-A
FC-C4	D0DZ-7A098-B
FC-C4A	C5AZ-7A098-C
FC-C4D	D3BZ-7A098-A
FC-C4N	D4FZ-7A098-A
FC-C5	E2DZ-7A098-A
FC-C54	E3TZ-7A098-A
FC-C6	D3TZ-7A098-A/B
FC-C6A	C6AZ-7A098-B

OEM #	LODI #
FC-C6E	E9TZ-7A098-A
FC-C6EP	F6TZ-7A098-AB
FC-C6N	D5AZ-7A098-AB
FC-CD4E	F3RZ-7A098-A
FC-CFT30	5F9Z-7A098-B
FC-CVTH	25420-PET-003
FC-DPO	77-01-467-106
FC-E40D4W	E9TZ-7A098-B
FC-E40D4WP	YC3Z-7A098-BA
FC-E4N71B	BV01-19-815
FC-ECVT	31728-KA031
FC-F1C1	MR515064
FC-F38CA	UNIVERSAL
FC-F3A	E7GZ-7A098-A
FC-F3AATX	F4BZ-7A098-A
FC-F3AE	FT21-19-815D
FC-F3AF	E9BZ-7A098-A
FC-F3AG	94140860
FC-F3AM	FT01-19-815
FC-F4A21	46321-22731
FC-F4A33	MD735572
FC-F4A411CA	MD752072
FC-F4A41A	MD758691
FC-F4A51A	MD758684
FC-F4A51D	MR350441
FC-F4A51T	46321-39010
FC-F4AEL	KFW01-21-500
FC-F516CA	UNIVERSAL
FC-FIOD	E0AZ-7A098-A
FC-FIOD4	E5TZ-7A098-A/C
FC-FIOD4E	F4TZ-7A098-A
FC-FIODE	F2VY-7A098-A
FC-FMX	D0AZ-7A098-A
FC-FMXF	D8AZ-7A098-A/B
FC-FNR5	FNC1-21-500A
FC-G4	25420-PC9-000
FC-G4AHL	FU50-21-500
FC-HONDA3	25420-PA9-000
FC-HONDAMATIC	25420-639-000
FC-HT700	29538491
FC-HT740	6839636
FC-HT750	23013625
FC-JATCO	31728-X0100
FC-JF403E	94385937
FC-JF403N	FX01-19-815
FC-JF506E	FP01-21-500
FC-JR503E	31728-60X01
FC-K4	25420-PK4-000
FC-KM170	MD707786
FC-KM171	MD707787
FC-KM175	MD737840
FC-KM176A	MD729955
FC-KM176N	46321-36011
FC-KM177	MD729954
FC-L1000	29537965
FC-L1000A	29537966
FC-L1000CA	29537268
FC-L4N71B	BT40-19-815A
FC-M101	77-00-739-883
FC-M41	31728-X0F00
FC-M41A	31728-X0100
FC-M4TA	25420-P56-003
FC-M4VA	25450-P4V-013

6.1 Tablas de equivalencias

Filtro y empaque de transmisión automática



OEM #	LODI #
FC-M4VAP	25420-P4V-003
FC-M7WA	25420-P7W-003
FC-M91A	25420-RXH-003
FC-MDLA	25420-P4R-013
FC-MJ3	77-00-727-430
FC-ML4A	25420-PL4-000
FC-MPJACA	25450-P7W-003
FC-MPRA	25420-PR0-030
FC-MPWA	25420-PW4-010
FC-MPXA	25420-PX4-701
FC-MPYA	25420-PY4-000
FC-MT640	6883044
FC-MURA	25420-RCK-004
FC-MV2A	25420-RV2-003
FC-MX1	94428489
FC-MX17	96053975
FC-PN3A	25420-RN3-003
FC-PWRGLIDE	6263005
FC-R4A51	MR357710
FC-R4AEL	BV92-19-815
FC-R4AXELA	31728-AA000
FC-R4AXELN	31728-AA011
FC-RE0F10A	31728-1XZ0A
FC-RE4F03V	31728-85X01
FC-RE4F04B	31728-85X0A
FC-RE4R03A	31728-51X02
FC-RE5R05A	31728-97X00
FC-RL3F01A	31728-01X10
FC-RN3F01A	31728-01X08
FC-SENTRA	31728-31X01
FC-SLYA	25420-PLY-003
FC-SMMA	25420-PWR-003
FC-SMMACA	25450-PWR-003
FC-SPCA	25420-RPC-003
FC-SZCA	25420-PHT-003
FC-TAAT	21002496
FC-TAATCA	21002303
FC-TF6/8	3515996
FC-TF6CH	3621456
FC-TF6G	8123042
FC-TF8	8126042
FC-TF81SC	60-27-0F099-0080
FC-TF8CH	2466849
FC-TH125	8660100
FC-TH180	5258130
FC-TH200L	8628299
FC-TH200NY	8630789
FC-TH200R4	8644931
FC-TH325	8632630
FC-TH325N	8365710
FC-TH350C	8641443
FC-TH350L	6261412
FC-TH350NY	8640848
FC-TH400	6437741
FC-TH400A	5579822
FC-TH400L	6437741
FC-TH425	6435766
FC-TH440N	8689918
FC-TH700A	8642933
FC-TH700E	8685950
FC-TH700E6	8651909
FC-TH700E8N	24208465
FC-TH700EP	24208835

OEM #	LODI #
FC-TH700N	8667689
FC-TSURU	31728-01X09
FC-U140E	35330-0W010
FC-U151E	35330-08010
FC-U341E	35330-0W020
FC-U540E	35303-67206
FC-U660E	35330-33050
FC-V4A51	MR528836
FC-VT25E	24226576
FC-VW003	003 325 421
FC-VW010	010 325 421A
FC-VW010A	010 325 421
FC-VW010E	01N 325 429
FC-VW01J	01J-301-519L
FC-VW02E	02E 325 429
FC-VW02EN	02E 325 429D
FC-VW095	095 325 429C
FC-VW098	01P 325 429
FC-VW09D	09D-325-429
FC-VW09E	09E 325 429
FC-VW09G	09G 325 429A
FC-VW09M	09M 325 429
FC-VWAG4	01M 325 429
FC-W3A040	115-270-03-98
FC-W3A040N	123-270-00-98
FC-W4A020	126-270-02-98
FC-W4A040	126-277-02-95
FC-W4B025	109-270-02-98
FC-W5A030	129-277-01-95
FC-W5A580	140-277-00-95
FC-ZF3HP22	24341-209-747
FC-ZF4HP14	1036-226-013
FC-ZF4HP18	7599525
FC-ZF4HP22	24311-218-550
FC-ZF5HP18	24341-219-631
FC-ZF5HP30	24341-422-419
FC-ZF6HP19	24117-536-387
FC-ZF6HP19A	09L 325 429
FC-ZF6HP26	24117-522-923
FC-ZF8HP45	0AT 325 429

PIONEER®

Automotive Industries

Ahora en México

Más de 65 años de experiencia en EUA

**Soportes de Motor
y Transmisión para
todas las marcas de vehículos**



Servicio Técnico
Lada sin costo: 01800 7330 333



Miembro de Grupo LODI

PERFECTION[®]

Performance Proven



**EL CLUTCH MÁS
VENDIDO EN
ESTADOS UNIDOS
AHORA EN MÉXICO**

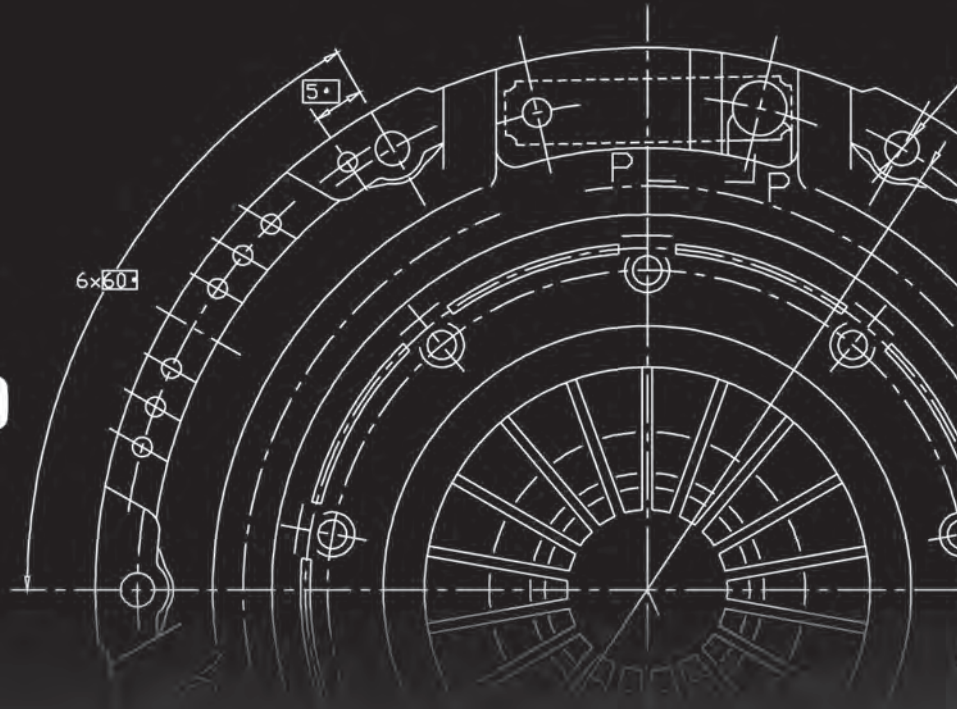

MAX[®]

performance

CABLES PARA BUJIAS

Spark Plug Wire Set



SILICÓN EPS
7/8 mm



EPDM
7/8 mm



RACING
8.5 mm



www.lodi.com.mx



LODI Industrias Automotrices

Dale Like !



INDUSTRIAS AUTOMOTRICES

Distribuido por:



Soporte técnico: 01800-227-5634
CAS LODI
info@lodi.com.mx



LODI Industrias Automotrices



@IALodi



811 813 4207